

ELECTRONIC COPY

UCRL-MA-109338 Pt. I

Numerical Electromagnetics Code – NEC-4

Method of Moments

Part I: User's Manual

(NEC-4.1)

Gerald J. Burke

January 1992



Lawrence
Livermore
National
Laboratory

CIRCULATION COPY
SUBJECT TO RECALL
IN TWO WEEKS

DISCLAIMER

This document was prepared as an account of work sponsored by an agency of the United States Government. Neither the United States Government nor the University of California nor any of their employees, makes any warranty, express or implied, or assumes any legal liability or responsibility for the accuracy, completeness, or usefulness of any information, apparatus, product, or process disclosed, or represents that its use would not infringe privately owned rights. Reference herein to any specific commercial product, process, or service by trade name, trademark, manufacturer, or otherwise, does not necessarily constitute or imply its endorsement, recommendation, or favoring by the United States Government or the University of California. The views and opinions of authors expressed herein do not necessarily state or reflect those of the United States Government or the University of California, and shall not be used for advertising or product endorsement purposes.

This report has been reproduced
directly from the best available copy.

Available to DOE and DOE contractors from the
Office of Scientific and Technical Information
P.O. Box 62, Oak Ridge, TN 37831
Prices available from (615) 576-8401, FTS 626-8401

Available to the public from the
National Technical Information Service
U.S. Department of Commerce
5285 Port Royal Rd.,
Springfield, VA 22161

Work performed under the auspices of the U.S. Department of Energy by Lawrence
Livermore National Laboratory under Contract W-7405-ENG-48.

Preface

NEC-4 is the latest version of The Numerical Electromagnetics Code — Method of Moments that has been developed at the Lawrence Livermore National Laboratory, Livermore, California, under the sponsorship of the U.S. Army, ISEC and CECOM, the Naval Ocean Systems Center and the Air Force Weapons Laboratory. The development of the version NEC-4 was sponsored by the U.S. Army ISEC at Ft. Huachuca, AZ. The NEC Method of Moments code started as an advanced version of the Antenna Modeling Program (AMP) developed in the early 1970's by MBAssociates for the Naval Research Laboratory, Naval Ship Engineering Center, U.S. Army ECOM/Communications Systems, U.S. Army Strategic Communications Command and Rome Air Development Center, under Office of Naval Research Contract N00014-71-C-0187.

The documentation for NEC-4 consists of three volumes:

- Part I: NEC User's Manual
- Part II: NEC Program Description — Theory
- Part III: NEC Program Description — Code

The documentation for successive versions of NEC has been prepared by updating manuals for previous versions of the code, starting from AMP. In some cases this led to minor changes in the original documents, while in many cases major modifications were required. Part III of the NEC-4 manual has not yet been completed, although the Code Manual for NEC-2 may be of some help in understanding parts of the NEC-4 code.

Over the years many individuals have been contributors to AMP and NEC, and are acknowledged here as follows:

R. W. Adams	K. K. Hazard	E. K. Miller
M. J. Barth	W. A. Johnson	J. B. Morton
H. Bosserman	D. L. Knepp	G. M. Pjerrou
J. K. Breakall	D. L. Lager	A. J. Poggio
J. N. Brittingham	A. P. Ludwigsen	E. S. Selden
G. J. Burke	R. J. Lytle	R. W. Ziolkowski
F. J. Deadrick		

Special mention is due to E. K. Miller who has provided the main driving force behind the development of the code and modeling techniques since the development of the code BRACKT which preceded AMP. A. J. Poggio has also made major contributions to the code

development and documentation throughout the development of NEC. Dr. W. A. Johnson provided valuable assistance in validating the model for wires penetrating the ground and the basic Sommerfeld integral evaluation, and Dr. R. W. Ziolkowski provided assistance and guidance in developing the asymptotic approximations for the field near ground.

The development of NEC has also benefitted greatly from suggestions and guidance from individuals at the sponsoring agencies. Particular mention is due to J. Logan, J. W. Rockway and S. T. Li at the Naval Ocean Systems Center and J. McDonald and R. Franklin at ISEC, Ft. Huachuca AZ.

Contents

1. Introduction	1
2. Modeling Guidelines	3
2.1 Wire Modeling	3
2.2 Small Loops	5
2.3 Voltage Source Models	6
2.4 Wire Grid Modeling of Surfaces	8
2.5 Patch Modeling of Surfaces	9
2.6 Models Including Ground	12
2.7 Insulated Wires	15
3. Program Input	17
3.1 Input Format	17
3.2 Structure Geometry Input	18
CM, CE – Text to Document Output	20
CW – Catenary Wire	21
GA – Wire Arc Specification	23
GC – Continuation Data for Tapered Wire	24
GE – End Geometry Input	26
GF – Read a NGF File	28
GH – Wire Helix or Spiral	29
GM – Coordinate Transformation	30
GR – Generate Cylindrical Structure	32
GS – Scale Structure Dimensions	34
GW – Straight Wire Specification	35
GX – Reflect Structure in Coordinate Planes	36
SM, SC – Multiple Patch Surface	39
SP – Surface Patch	41
3.3 Program Control Commands	44
CP – Maximum Coupling Calculation	46
EN – End of Run	47
EX – Structure Excitation	48
FR – Set Frequencies	52
GD – Additional Ground Parameters	53

GN – Ground Parameters	55
IS – Insulated Wire	58
JN – Junction Charge Distribution	59
LD – Impedance Loading	60
LE – Near Electric Field Along a Line	63
LH – Near Magnetic Field Along a Line	64
NE – Near Electric Field	65
NH – Near Magnetic Field	67
NT – Non-Radiating Networks	69
NX – Next Structure	72
PQ – Printing Options for Charge on Wires	73
PS – Print Electrical Lengths of Segments	74
PT – Printing Options for Currents on Wires	75
RP – Radiation Pattern	76
TL – Transmission Line	79
UM – Upper Medium Parameters	81
VC – Voltage-Source End Caps	82
WG – Write NGF File	83
XQ – Execute	84
3.4 Examples of Structure Geometry Data	85
3.5 Auxiliary Program SOMNTX	90
3.6 Numerical Green's Function Option	93
4. NEC Output	96
4.1 The Output File Format	96
4.2 Examples of NEC Output	99
4.2.1 Examples 1 through 4	102
4.2.2 Example 5, Log-Periodic Antenna	121
4.2.3 Example 6, Cylinder with Attached Wires	128
4.2.4 Examples 7 and 8, Scattering by a Wire and Aircraft	137
4.2.5 Example 9, Scattering by a Sphere	147
4.2.6 Example 10, Horizontal Wires Near Ground	155
4.2.7 Example 11, Monopole Antenna on a Ground Stake	168
4.2.8 Example 12, Monopole Antenna on a Radial-Wire Ground Screen	173

5. Error Messages	182
6. Array Dimension Limitations	194
7. Differences Between NEC-4 and NEC-3	195
References	199

1. Introduction

The *Numerical Electromagnetics Code (NEC) — Method of Moments* is a computer program for analyzing the electromagnetic response of antennas and scatterers. The code is based on the numerical solution of integral equations by the method of moments, and combines an electric-field integral equation for modeling thin wires with a magnetic-field integral equation for closed perfectly conducting surfaces. This manual describes the use of the NEC-4 program which is the latest in a series of NEC-MoM programs, and includes a number of changes to improve modeling accuracy. Other versions of NEC currently in use include NEC-2, which can model wire structures in free space or over finitely conducting ground, and NEC-3 which is the same as NEC-2 but can also model wires buried in the ground or penetrating from air into ground.

These codes offer a number of features for modeling antennas or scatterers and their environments, including excitation by voltage sources or plane waves, lumped or distributed loading, and networks and transmission lines. The code output includes current distributions, impedances, power input, dissipation and efficiency, and radiation patterns and gains or scattering cross section. The model description and instructions for running the code are generally entered as commands read from an input file, although independent pre- and post-processors have been developed to streamline this process [1].

The modeling algorithms in NEC-4 have been revised to avoid loss of precision when modeling electrically small structures. The single-precision (32-bit) code will now give accurate results for many electrically small models that would have required double precision with NEC-3 or earlier codes. Also, a new treatment is used for wire radius and junctions for accurate modeling of stepped-radius wires and junctions of tightly coupled wires. Some other minor features have been added for convenience in modeling, and the insulated-wire model, that was available in a special version of NEC-3, is now included in the standard NEC-4 code. Also, the code structure has been extensively revised, with more use of Fortran 77 constructs, to make it more modular and easier to understand and maintain.

NEC-4 and earlier versions of NEC have been used to model a wide variety of antennas and scatterers including antennas in complex environments such as ships and aircraft. However, since the computer time and resources required by the moment-method solution increase with increasing size of the model relative to the wavelength, the solution may become difficult or impractical for large structures at high frequencies. The approach used in NEC is most applicable to the types of problems encountered at HF, VHF and lower frequencies. Problems such as a UHF antenna on a surface, or even a VHF antenna on a large aircraft may be handled better with other techniques such as the GTD approach used in the NEC Basic Scattering Code [2]. Also, finite difference codes [3] may be better suited to problems involving volumes of many cubic wavelengths or for interior coupling problems.

This manual describes how to use NEC-4. Section 2 contains guidelines for building

model descriptions. It is very important that these guidelines be understood and followed. In most cases there will be no warning if they are not followed, but results will be inaccurate. Section 3 describes how to set up an input file to describe a model and request computation of various results. The main part of section 3 is a listing of all commands with a detailed description of the command parameters. Section 4 includes listings of the input and output for sample problems. A number of important points about the output are noted in the discussions of these examples. Section 5 contains a listing of all error messages that may be produced by NEC-4. Section 6 describes the parameters that set array dimensions in the code. These parameters limit the size of models that may be run or the number of certain types of input commands. If a limit is exceeded an error message will be printed. The user can then increase the parameter and recompile the code. Section 7 is a summary of differences between NEC-4 and the previous code NEC-3.

Details of the mathematical and numerical techniques used to model wire and surface structures can be found in the NEC-4 Theory Manual [4], Part II of the NEC-4 documentation. Persons wanting to learn to use NEC should start with the this User's Guide. Details of the subroutines and code structure have been left for Part III of the manual, Program Description - Code. The Code Manual has not been completed at this time, but the NEC-2 Code manual, Part II of the NEC-2 documentation [5], should be of some use in understanding parts of the NEC-4 code.

2. Modeling Guidelines

The basic devices for modeling structures with NEC are short, straight segments for modeling wires and flat patches for modeling surfaces. An antenna and any other conducting objects in its vicinity that affect its performance must be modeled with strings of segments following the paths of wires and with patches covering surfaces. Proper choice of the segments and patches for a model is the most critical step to obtaining accurate results. The number of segments and patches should be the minimum required for accuracy, however, since the program running time increases rapidly as this number increases. Guidelines for choosing segments and patches are given below and should be followed carefully by anyone using NEC. Experience gained using the code will also aid the user in developing models.

2.1 Wire Modeling

A wire segment is defined by the coordinates of its two end points and its radius. Modeling a wire structure with segments involves both geometrical and electrical factors. Geometrically, the segments should follow the paths of conductors as closely as possible, using a piece-wise linear fit on curves. It is usually better to keep the length of a piece-wise linear path approximately equal to that of the continuous curve rather than inscribing or circumscribing the path, although the difference should not be great if the segments are sufficiently short.

The main electrical consideration is segment length Δ relative to the wavelength λ . Generally, Δ should be less than about 0.1λ at the desired frequency. Somewhat longer segments may be acceptable on long wires with no abrupt changes while shorter segments, 0.05λ or less, may be needed in modeling critical regions of an antenna. The size of the segments determines the resolution in solving for the current on the model, since the current is computed at the center of each segment. Earlier versions of NEC suffered a loss of precision or complete failure of the solution when very short segments were used, but this problem has been corrected in NEC-4. The extremely short segments can be used with NEC-4, subject to limitations related to the wire radius as discussed below.

The wire radius a relative to λ is limited by the approximations used in the kernel of the electric field integral equation. NEC uses the thin-wire approximation, neglecting transverse currents on wires and assuming that the axially directed current is uniformly distributed around the segment surface. The acceptability of these approximations depends on both the value of a/λ and the tendency of the excitation to produce circumferential current or current variation. Unless $2\pi a/\lambda$ is much less than 1, the validity of these approximations should be considered.

The accuracy of the solution for the axial current is also dependent on Δ/a , due to approximations in the evaluation of the thin-wire kernel. Small values of Δ/a may result in oscillations in the computed current near free wire ends, voltage sources, lumped loads

or changes in wire radius. NEC-3 and previous codes offered two options for the thin-wire solution, the Thin-Wire Approximation and the Extended Thin-Wire Approximation. NEC-4 has only one thin-wire model that is different than in earlier codes, but is essentially equivalent to the Extended Thin-Wire Approximation in NEC-3. Obvious instabilities in the current near wire ends may occur for Δ/a less than about 0.5, and values of Δ/a several times larger should be used if possible.

The current expansion used in NEC enforces conditions on the current and charge density along wires, at junctions and at wire ends. For these conditions to be applied properly, segments that are electrically connected must have coincident end points. If segments intersect other than at their ends, NEC will not allow current to flow from one segment to the other. A tolerance is allowed in determining connections, with segments considered connected if the separation of their ends is less than 10^{-3} times the length of the shortest segment. When possible, however, identical coordinates should be used for connected segment ends.

The angle of intersection of wire segments in NEC is not explicitly restricted. Hence the acute angle may be made so small as to place the observation point on one wire segment within the volume of another wire segment. Such overlapping segments cannot be modeled accurately with the thin-wire approximation. Numerical studies have shown increasing errors when the center point of one segment approaches within a radius-length of the surface of an adjacent segment. Even with larger angles of intersection, the details of the current distribution in the region of a bend cannot be represented accurately in the thin-wire approximation, but the results for current should be accurate at a distance from the bend.

Other rules affecting wire-segment models follow:

- Segments may not overlap, since the division of current between two overlapping segments is indeterminate. Overlapping segments may result in a singular matrix equation.
- A segment is required at each point where a network connection or voltage source will be located. This may seem contrary to the idea of an excitation gap as a break in a wire. However, a continuous wire across the gap is needed so that the required voltage drop can be specified as a boundary condition.
- The minimum separation of parallel wires is limited by the thin-wire approximation. The actual error versus separation has not been well determined, but a limit on the separation between wire axes of two or three times the largest diameter seems reasonable. When parallel wires are close together they should, if possible, have equal segment lengths, with the segment ends aligned, to avoid incorrect current perturbations from offset match points and segment junctions.

If possible, it is good to vary parameters in a model to gain an understanding of the effect on results. Increasing the number of segments, perhaps by a factor of two, will give an

indication of the convergence error in the moment-method solution. Changing the frequency slightly can reveal sensitivity of the results. In the vicinity of a very sharp resonance, small modeling errors, resulting either from numerical errors or simplifications made to the physical model, can result in large changes in antenna impedance or gain. In such a case, the best approach may be to compute results over a band of frequencies rather than looking at any one frequency.

There are some self-consistency checks than can be obtained from NEC output. These include checking how well the boundary condition on electric field is being satisfied along wires, the balance of input and radiated power, and reciprocity. When possible these checks should be considered to help validate a model. Uses of internal checks are demonstrated in the discussion of the NEC output in section 4 of this manual.

2.2 Small Loops

Although the conditions leading to errors with electrically short segments have been corrected in NEC-4, there can still be a loss of precision or failure of the solution for small loops. The problem is that the solution for small loops using point matching and localized current expansion functions in NEC can result in an ill-conditioned matrix. The problems seen will depend on whether the loop contains a voltage source or is excited by external coupling. Results for input admittance of a loop antenna, computed with NEC-3 and NEC-4, are shown in figure 1 with frequency decreasing until the solution fails. The single precision (32 bit) code NEC-3S is seen to fail at a loop circumference of 0.07λ , while the double precision code NEC-3D reaches $3(10^{-4})\lambda$. The single precision NEC-4S fails at about 0.002λ . The fourth plot in figure 1 is from a code similar to NEC-4 but that replaces one match point and one basis function on the loop with functions that prevent the matrix from becoming ill-conditioned [6]. This option for loops is not available in the present NEC-4, but may be in a future version.

When the loop does not contain a voltage source but is excited by external coupling the errors due to the point-matched solution in NEC, combined with the ill-conditioned matrix of a small loop, may result in an incorrect solution with large currents circulating in the loop. This problem occurs when the loop is excited by the field due to nearby charge concentrations on wire ends. Use of double precision may not improve the solution, since the main problem is the errors due to point matching. The use of loop basis and weighting functions is the only way to avoid these errors. Otherwise, cases of close coupling of a small loop to wire antennas should be avoided. Fortunately the circulating currents do not radiate strongly until they become large, and then they are usually apparent in a plot such as can be obtained from the NECPLT program. An example is shown in figure 2. Computing the average gain, as a check on the balance of input and radiated power, can also reveal errors due to circulating currents.

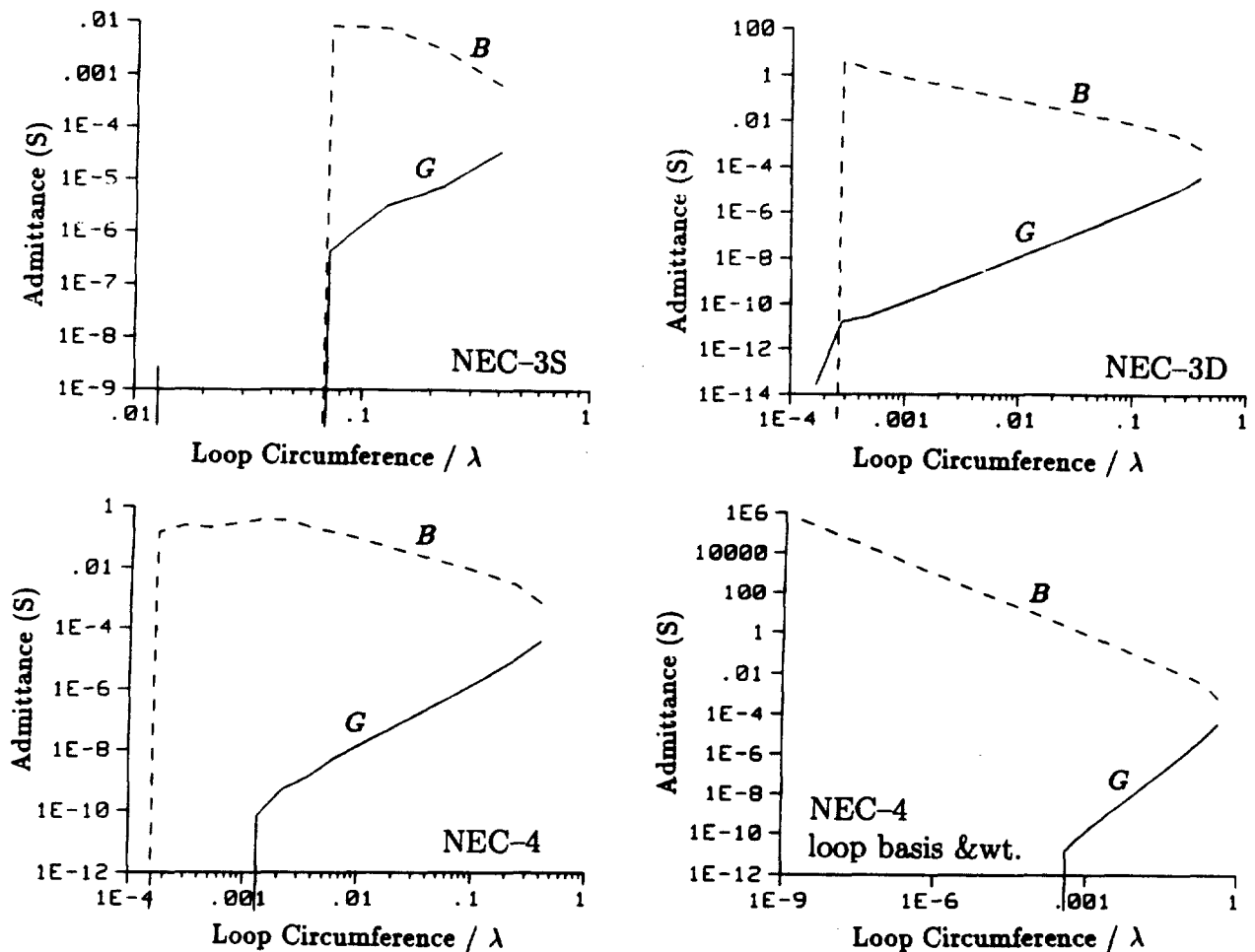

Fig. 1 Input admittance of a loop antenna computed by NEC-3S, NEC-3D and NEC-4S with and without loop basis and weighting functions. The loop was modeled with 22 segments and the ratio of wire radius to loop radius was 0.042. Solution failure is shown by deviation from the low frequency asymptotic behavior.

2.3 Voltage Source Models

Modeling voltage sources is probably the most critical step in the moment-method analysis of wire antennas, since errors are directly reflected in the computed input admittance and hence in the gain and other related quantities. NEC offers two models for voltage sources on wires, the applied-field source and the bicone source.

In the applied-field source model for a voltage V_i on segment i , the electric field at the match point on segment i is set to $E_i = V_i/\Delta_i$ where Δ_i is the segment length. The segments on either side of the source segment should have the same length Δ_i . When this rule is followed, the electric field along the wire will be found to have the prescribed value at the center of the source segment, remain approximately constant over the segment and drop to small values beyond the region of the segment ends. When multiple wires are connected to one end of the source segment, the length of each segment at the junction should be made equal to that of the source segment if possible. However, it appears to be less important, to maintain equal segment lengths across a junction than on a continuous wire.

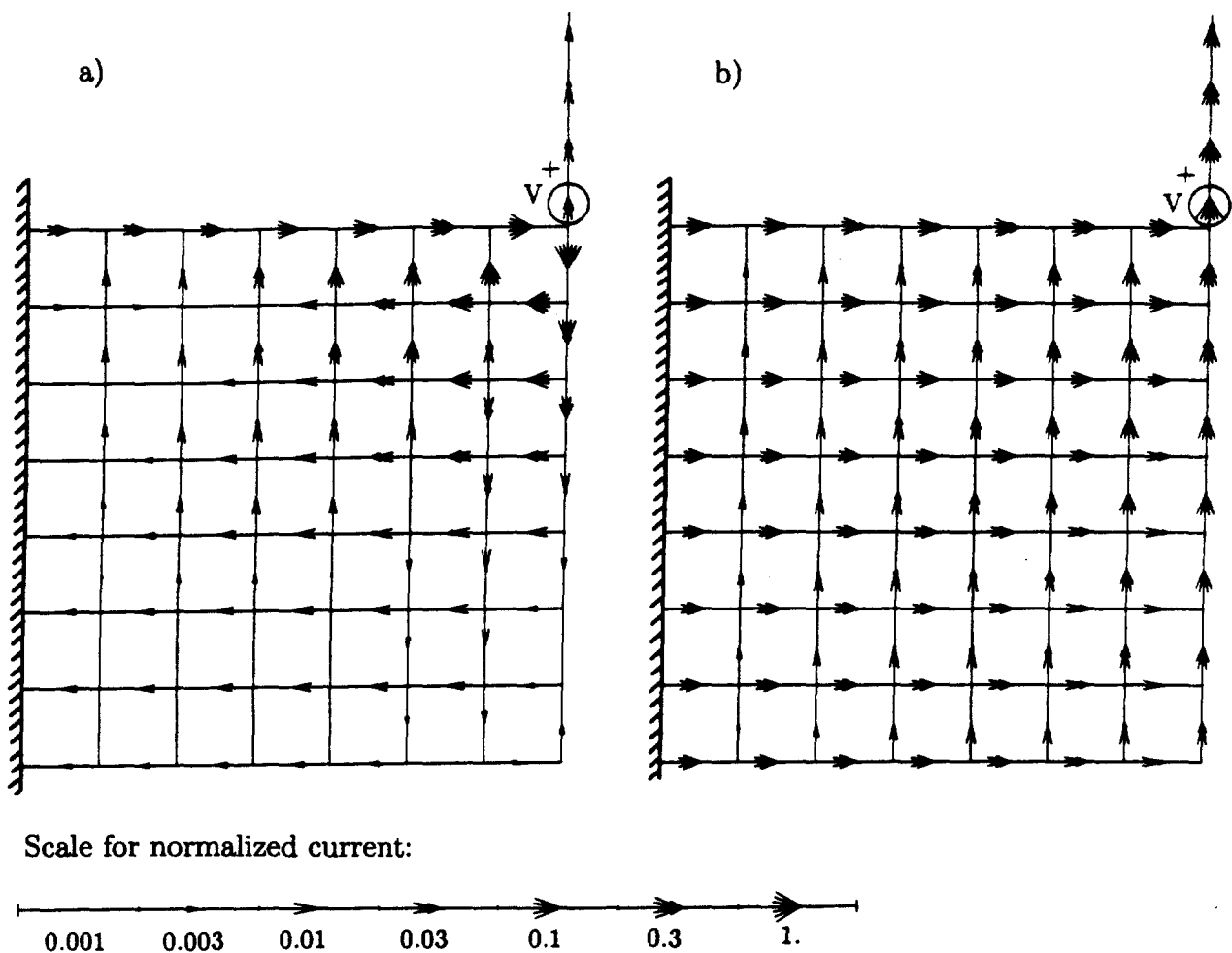

Fig. 2 Imaginary part of current on a wire-grid fin with stub antenna. The source is one volt at the base of the stub, and current is normalized by I_{\max} ; a) NEC-3D result with incorrect circulating current, $I_{\max} = 1.62$ mA; b) NEC-4S with loop basis and weighting functions, $I_{\max} = 0.10$ mA.

The field distribution over the source region can be checked by using the LE command to compute electric field along the wire surface. The field distribution should be roughly rectangular on thin wires. With larger wire radius the distribution will be more rounded, since the field cannot change significantly over a distance much less than the wire radius. However, the important condition is that the line integral of the field across the source region should be equal to the source voltage. This condition is usually satisfied with the applied-field source over a wide range of segment radii and lengths.

The other voltage source model offered in NEC is the bicone source. In this model the voltage is introduced at the junction between segments, rather than on a segment, by forcing a discontinuity in the charge density in the current expansion. The source voltage is related to the discontinuity in charge density through the model of a biconical transmission line. The segments on each side of a bicone voltage source should be collinear and have the same length and radius.

The motivation behind the bicone source was to obtain a more localized distribution of the source field. The field distribution is localized in the junction region if the wire radius is sufficiently small. However, the field becomes more distributed with larger wire radius. More important, the condition relating the source voltage to the charge distribution is not accurate for large wire radius. Hence the bicone source model should only be used with very thin wires, and then only with caution. It yields reasonably accurate input impedances on a dipole with length $\ell = \lambda/2$ when the thickness parameter $\Omega = 2 \ln \ell/a$ is greater than about 15. However, the model also fails with decreasing Δ/a . Hence it is recommended that the applied-field source model be used in most cases.

2.4 Wire Grid Modeling of Surfaces

Conducting surfaces can sometimes be modeled as wire grids, using the equivalence of a solid conducting surface with a grid having sufficiently small mesh size. Unlike the surface-patch model in NEC, based on the magnetic-field integral equation, a wire grid can be used to model thin plates, open shells and finitely conducting surfaces. A single wire grid can represent the exterior of a solid body or both surfaces of a thin conducting plate. The current on the grid will be the sum of the currents that would flow on the opposite sides of the plate. While the information about the currents on the individual surfaces is lost, the total current will yield the correct radiated and near fields.

Wire-grid modeling of conducting surfaces has been used with varying success. The earliest applications to the computation of radar cross sections and radiation patterns provided reasonably accurate results [7]. Even computations for the input impedance of antennas driven against grid models of surfaces have oftentimes exhibited good agreement with experiments. However, broad and generalized guidelines for near-field quantities have not been developed, and the use of wire-grid modeling for near-field parameters should be approached with caution. Incorrect circulating currents in the mesh can sometimes be a problem, as shown in figure 2.

Wire grids are generally constructed as a rectangular mesh of segments, although other shapes can be used to fit irregular surfaces. If a preferred direction for current is evident more wires can be run in that direction. The mesh size should be about 0.1λ on a side or smaller. This size is not too critical, and a larger mesh, perhaps with more than one segment per side, might be used on surfaces far from the driven antenna. The grid should include wires outlining the corners of the structure. The rules for wire modeling, including a/λ and Δ/a should be followed.

The choice of wire radius in the mesh is somewhat uncertain, since it does not correspond to any physical characteristic of the surface. It has been found that a mesh of thin wires has excess inductance and not enough capacitance when compared with a solid surface [8]. To correct this difference, it is generally recommended that the segment radius be chosen so that $2\pi a = d$ where d is the separation of wires in the mesh. This condition is sometimes called "the equal area rule" since the surface area of the wires in one direction on the grid is equal to the area of one side of the surface. The advantage of the equal area rule has been demonstrated by Ludwig [9] for a cylinder formed with parallel wires, and other results supporting it are presented in [10].

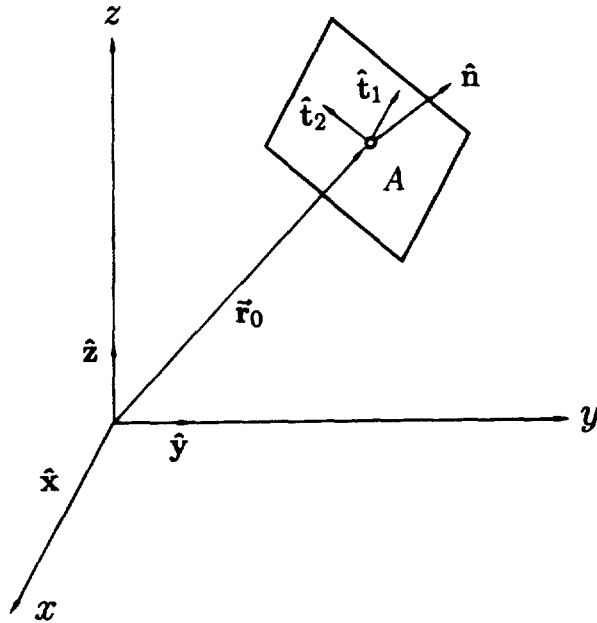

Fig. 3 Patch position and orientation.

2.5 Patch Modeling of Surfaces

NEC includes an option for modeling conducting surfaces with surface patches. This formulation uses the Magnetic Field Integral Equation, and is restricted to closed surfaces with non-vanishing enclosed volume. It is not applicable to a conducting plate or shell of zero thickness. In fact, any condition, such as a gap or finite conductivity, that would allow the field to reach the inside of the surface is not allowed with the MFIE. The model works very well for a shape such as a sphere. It can be used for structures with edges, such as a cube, but reasonably small and uniform patches should be used along the edge to maintain accuracy. Also, a wire antenna cannot be connected at an edge. Theoretically the MFIE can be used for a thin box or cylinder, but the solution may become inaccurate due to the decreasing condition number of the matrix and the simple point matching and pulse current expansion used in the solution in NEC.

A conducting surface is modeled by means of multiple, small flat surface patches corresponding to the segments used to model wires. The patches are chosen to cover completely the surface to be modeled, conforming as closely as possible to curved surfaces. The parameters defining a surface patch are the Cartesian coordinates of the patch center, the components of the outward-directed unit normal vector and the patch area. These are illustrated in figure 3, where $\mathbf{r}_0 = x_0\hat{x} + y_0\hat{y} + z_0\hat{z}$ is the position of the segment center; $\hat{\mathbf{n}} = n_x\hat{x} + n_y\hat{y} + n_z\hat{z}$ is the outward unit normal vector and A is the patch area. Although the shape (square, rectangular, etc.) may be used to define a patch on input, it does not affect the solution, since there is no integration over the patch unless a wire is connected to the patch center. The program computes the surface current on each patch along the orthogonal unit vectors $\hat{\mathbf{t}}_1$ and $\hat{\mathbf{t}}_2$, which are tangent to the surface. The vector $\hat{\mathbf{t}}_1$ is parallel to a side of the triangular, rectangular or quadrilateral patch. For a patch of arbitrary shape,

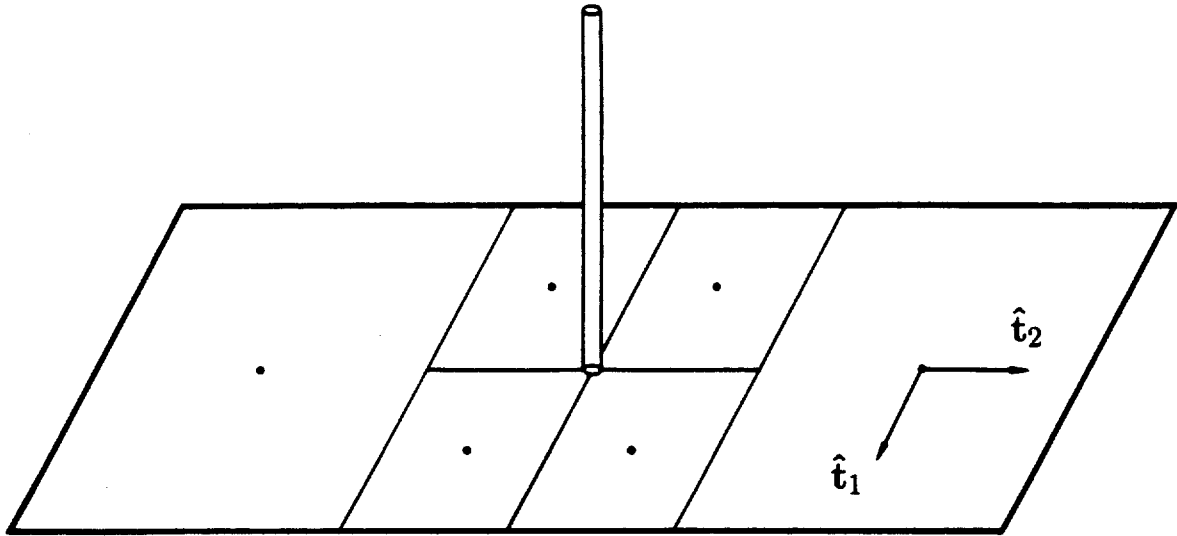

Fig. 4 Connection of a wire to a surface patch.

it is chosen by the following rules:

$$\begin{aligned} \hat{t}_1 &= \hat{x} && \text{for a horizontal patch} \\ \hat{t}_1 &= (\hat{z} \times \hat{n}) / |\hat{z} \times \hat{n}| && \text{for a non-horizontal patch.} \end{aligned}$$

Then \hat{t}_2 is chosen as $\hat{t}_2 = \hat{n} \times \hat{t}_1$. When a structure having plane symmetry is formed by reflection in a coordinate plane using a GX command, the vectors \hat{t}_1 , \hat{t}_2 and \hat{n} are also reflected. Hence the new patches will have $\hat{t}_2 = -\hat{n} \times \hat{t}_1$.

When a wire is connected to a surface, the wire must end at the center of a patch, with identical coordinates used for the wire end and the patch center. The program then divides the patch into four equal patches about the wire end as shown in figure 4, where a wire has been connected to the second of three previously identical patches. The connection patch is divided along lines defined by the vectors \hat{t}_1 and \hat{t}_2 for that patch, with a square patch assumed. The four new patches are ordinary patches like those input by the user, except when the interactions between these patches and the lowest segment on the connected wire are computed. In this case an interpolation function is applied to the four patches to represent the current from the wire onto the surface, and the function is numerically integrated over the patches. Thus, the shape of the patch is significant in this case. The user should try to choose patches so that those with wires connected are approximately square with sides parallel to \hat{t}_1 and \hat{t}_2 . The connected wire is not required to be normal to the patch but cannot lie in the plane of the patch. Only a single wire can connect to a given patch, and a segment can have a patch connection on only one of its ends. Also, a wire can never connect to a patch formed by subdividing another patch for a previous connection, such as the smaller patches in figure 4.

As with wire modeling, patch size measured in wavelengths is very important for accuracy of the results. A minimum of about 25 patches should be used per square wavelength of surface area, with the maximum size for an individual patch being about $0.04\lambda^2$. Large

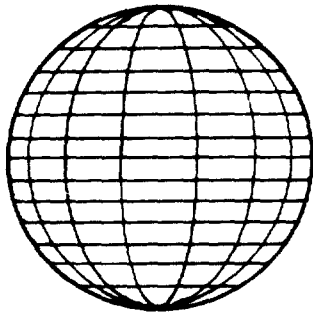

Uniform Segmentation

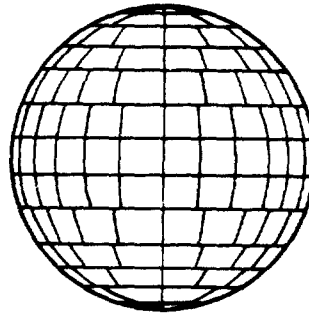

Variable Segmentation

Fig. 5 Patch models for a sphere.

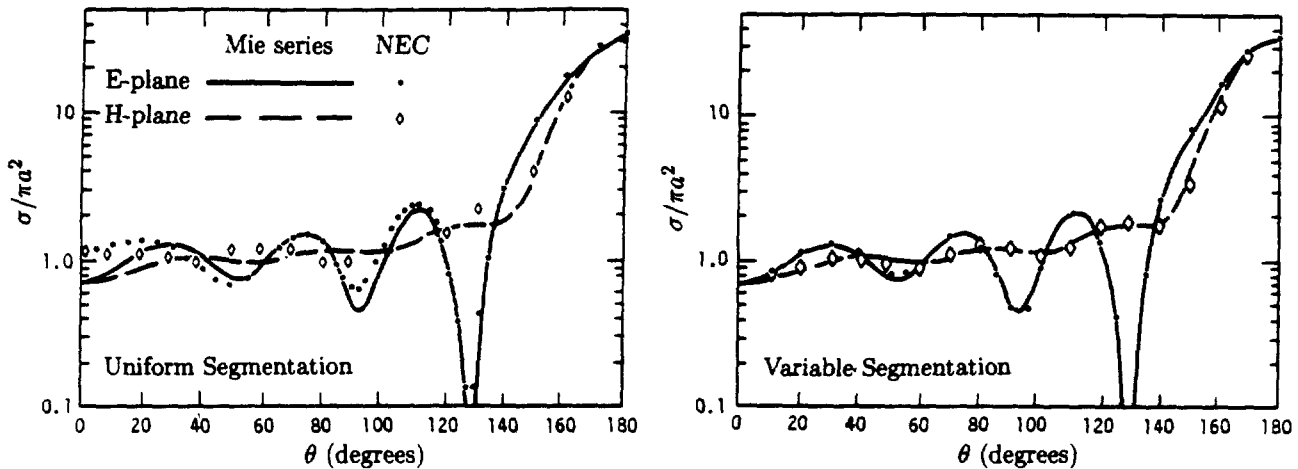

Fig. 6 Bistatic scattering cross section of a sphere with $ka = 5.3$, comparing results from NEC patch models with the Mie series solution from [11].

patches may be used on large smooth surfaces, while smaller patches are needed in areas of small radius of curvature, both for geometrical modeling accuracy and for accuracy of the integral equation solution. In the case of a square edge, a precise local representation cannot be included; however, smaller patches in the vicinity of the edge can lead to more accurate results since the current magnitude may vary rapidly in this region. Since connection of a wire to a patch causes the patch to be divided into four smaller patches, a larger patch may be input in anticipation of the subdivision.

While patch shape is not input to the program, very long narrow patches should be avoided when subdividing the surface. This point is illustrated by the two methods of modeling a sphere shown in figure 5. The first uses uniform divisions in azimuth and equal cuts along the vertical axis. This results in all patches having equal areas, but with long narrow patches near the poles. In the second method, the number of divisions in azimuth is increased toward the equator so that the patch length and width are kept more nearly equal. The areas are again kept approximately equal. The results of the two segmentations are shown in figure 6 for scattering by a sphere of ka ($2\pi \times \text{radius}/\lambda$) equal to 5.3. The uniform segmentation used 14 segments in azimuth and 14 equal slices along the vertical axis. The

variable segmentation used 13 equal increments in arc length along the vertical axis, with each band from top to bottom divided into the following number of patches in azimuth: 4, 8, 12, 16, 20, 24, 24, 24, 20, 16, 12, 8, 4. Much better agreement with the Mie series results from [11] is obtained with the variable-segmentation model.

In general, the use of surface patches is restricted to modeling voluminous bodies. The surface modeled must be closed, since the patches only model the side of the surface from which their normals are directed outward. If a somewhat thin body, such as a box with one narrow dimension, is modeled with patches, the narrow sides (edges) must be modeled as well as the broad surfaces. Furthermore, the parallel surfaces on opposite sides cannot be too close together or severe numerical errors may occur.

2.6 Models Including Ground

NEC-4 can model structures in an infinite medium, with arbitrary dielectric constant and conductivity, or near an interface between free space and ground. An infinite medium is specified with the UM command. No other change in the model is needed except that the segment and patch sizes must be based on the wavelength in the medium, not the free space wavelength. The limitations on segment and patch sizes should be reduced by the magnitude of the index of refraction of the medium. Thus if the relative permittivity of the medium is ϵ_r and the conductivity is σ in S/m with frequency f_{MHz} in MHz, the real parameter $\lambda_c = 299.8/(|n|f_{\text{MHz}})$ should be used for λ in determining segment and patch sizes, where $n = (\epsilon_r - j\sigma/\omega\epsilon_0)^{1/2}$ and

$$|n| = \left[\epsilon_r^2 + 3.23(10^8) \left(\frac{\sigma}{f_{\text{MHz}}} \right)^2 \right]^{1/4}$$

Several options are available in NEC for modeling an antenna near an interface between two media. These options are selected with the GN command. For an antenna over a perfectly conducting ground the code generates an image of the structure reflected in the ground plane. The image is exactly equivalent to a perfectly conducting ground, and the solution accuracy should be comparable to that for the model in free space. Structures can be close to a perfectly conducting ground or contacting it. However, a horizontal wire should have a height of at least several times the wire radius for the thin-wire approximation to be valid. The image solution doubles the time to fill the moment-method interaction matrix.

A finitely conducting ground plane may be modeled with a modified-image solution known as the Reflection Coefficient Approximation (RCA) or with a method based on the exact Sommerfeld-integral solution for a source near an interface. The RCA solution evaluates the field of the image multiplied by the Fresnel plane-wave reflection coefficients, and hence can only be used with antennas sufficiently far from the interface. The RCA can be used with both wire and patch models, but only when all structures are on the same side of the interface. If the RCA is selected when there are conductors on both sides of the interface the run will terminate with an error message since interactions across the interface cannot be computed. The RCA is fast but of limited accuracy and should not be used for structures close to the ground surface. Wires should be at least several tenths of a wavelength above the

ground, and the RCA cannot be used to model long-wire antennas over ground. Long-wire antennas modeled with the RCA can produce a current that grows exponentially away from the source due to errors in the approximation. The time to fill the interaction matrix is doubled with the RCA due to the computation of the field of the image.

A UM command can be used with the RCA to define an upper medium other than free space. The structure to be modeled should be on the side of the interface having the smaller index of refraction, since the RCA is not accurate otherwise.

To accurately model structures near the interface or involving interactions across the interface, the Sommerfeld-integral option must be selected by entering a 2 as the first parameter on the GN command. To use this option, the program needs an input file with Sommerfeld-integral values for the specific ground parameters and frequency of the model. This file may be generated in advance by running the auxiliary program SOMNTX. If NEC-4 cannot find the Sommerfeld-integral file specified on the GN command it will generate the values. In either case, generating the Sommerfeld-integral tables requires a moderate amount of computer time (about 55 seconds on a VAX 6330.) Hence it may be worthwhile for the user to build his own library of Sommerfeld-integral files for frequently used cases. When the Sommerfeld-integral option is used, the time to evaluate the interaction matrix in NEC is about eight times that for free space.

The Sommerfeld-integral solution has not been implemented in NEC-4 for patches. If it is requested for a model involving patches, the wire-to-wire interactions will be computed from the Sommerfeld-integral tables, while wire-to-patch and patch-to-patch interactions will be evaluated using the RCA. Models involving interactions across the interface cannot use patches and will result in termination of the run with an error message. Also, a UM command cannot be used with the Sommerfeld-integral option, since the upper medium must be free space.

In the Sommerfeld-integral model the fields are evaluated from the exact Sommerfeld-integral solution for a source near the ground, but table lookup and asymptotic approximations are used to obtain field values quickly during the moment-method solution. When the separation of source (or the image for reflection) and evaluation points is less than $2\lambda_0$ vertically or $3\lambda_0$ horizontally the interaction fields are obtained by interpolation in tables of Sommerfeld-integral values. This table-lookup is used only to a depth of $0.8 \min(1/|n|, 0.3)\lambda_0$ in the ground. For greater separations of source and evaluation points the fields are evaluated using asymptotic approximations. The asymptotic approximations include two rays, with the contribution of the ray traveling mostly above ground including higher-order terms and surface wave. The ray traveling mostly below ground (the lateral wave when source and evaluation points are on or above the interface) is represented by only a first-order approximation which vanishes when source and evaluation points are on or above the interface. Hence, the lateral wave for antennas above ground is not computed at distances beyond the table-lookup region. For typical grounds and antenna applications the missing lateral wave should be negligible. More information on the field evaluation near ground can be found in the NEC-4 Theory Manual [4].

In the Sommerfeld-integral solution, a non-horizontal wire can penetrate the interface if the point of penetration coincides with a junction between segments. Individual segments must be completely above or below the interface. It is usually convenient to use separate GW commands to specify the parts of the wire above and below the interface, since this ensures that the interface intersects the wire at a junction and permits choosing the segment lengths as needed in each medium. The wire radius should not change at the point where the wire crosses the interface. Antennas on ground stakes and buried ground screens have been modeled with apparently good results [12]. The voltage source in these models was located on the first segment above the interface.

To model a buried radial-wire ground screen, the junction of the monopole and the ground screen can be located at the interface with the first segment of each radial wire sloping downward to the desired depth. Models of radial-wire ground screens may require a very large number of segments. Screens with several hundred radials have been modeled with the code NEC-GS, which is a version of NEC-3 specialized to take maximum advantage of azimuthal symmetry with a wire on the axis of rotation [13]. Results for buried ground screens appear to be well converged and accurate as long as the criteria for segment lengths in the two media are followed. However, models for electrically small screens have not been validated as well as for larger screens. Caution should be exercised in modeling small screens, particularly in obtaining values for small quantities such as input resistance.

Radial wire screens above the ground can be modeled with the junction of the monopole and screen located at the screen height. However, results for elevated screens may converge more slowly than for buried screens. When modeling a monopole on a screen above ground, the lengths of segments at the junction, on both the radial wires and the monopole, should be on the order of the screen height or less. Segment lengths can be tapered to larger values away from the junction to reduce the total number of segment needed.

When the radiated field is evaluated using the RP 0,... command the direct and reflected fields are evaluated using the Fresnel plane-wave reflection coefficients. This yields the exact result for the component of the field varying as $1/R$, which is the definition of radiated field. However, this radiated field goes to zero on the interface. To obtain the field near the interface at a finite distance from the source, the RP 1,... option must be used to include the surface wave. Note that the coordinates change from Cartesian to Cylindrical on the RP command. The surface wave may be calculated when either the Sommerfeld-integral or RCA solution has been used for the currents.

When the NE or LE commands are used to compute the near electric field the evaluation uses the same method that was used to compute the currents - either the RCA or Sommerfeld-integral evaluations as selected by the GN command. With the RCA, the field near the interface at a distance from the source may be greatly under estimated due to the missing surface wave. The RP 1,... evaluation should be used in such a case. When the NH or LH commands are used in a Sommerfeld-integral solution the magnetic field is evaluated from a finite-difference approximation of $\nabla \times \mathbf{E}$. This yields a complete evaluation of the field over ground, although errors may be magnified by the differences. Also, the time to evaluate the magnetic field at a single point will be six times that for electric field.

NEC also includes options for a radial-wire ground-screen approximation and two-medium ground approximation (cliff) based on modified reflection coefficients. These methods are implemented only for wires and not for patches, and cannot be used with the Sommerfeld-integral solution. For the radial-wire ground-screen approximation, an approximate surface impedance – based on the wire density and the ground parameters – is computed at specular reflection points. Since the formula for surface impedance yields zero at the center of the screen, the current on a vertical monopole will be the same as over a perfectly conducting ground. The ground screen approximation is used in computing both near-field interactions and the radiated field. It should be noted that diffraction from the edge of the screen is not included in the model. When limited accuracy can be accepted, the ground screen approximation provides a large time saving over explicit modeling using the Sommerfeld-integral solution, since the ground screen approximation does not increase the number of unknowns in the matrix equation.

The two-medium ground approximation permits the user to define a linear or circular cliff with different ground parameters and ground height on opposite sides of the boundary. This approximation is not used for the near-field interactions affecting the currents, but is used in computing the radiated field. The reflection coefficient is based on the ground parameters and height of the ground at the specular-reflection point for each ray. Since the currents are always computed assuming the antenna is over an infinite ground plane with the inner-medium parameters, this approximation can be used to compute the current over a perfectly conducting ground and then compute radiated fields for a finitely conducting ground. To do this, the inner medium can be defined with a circular boundary of nearly zero radius so that it does not affect the radiated field.

2.7 Insulated Wires

Segment lengths on insulated wires should be chosen relative to the effective electrical length of the wire. When the index of refraction of the sheath material is higher than that of the surrounding medium, the propagation constant along the wire will be greater than in the outer medium. However, for sheath thicknesses within the limits that can be handled by NEC, the difference should not be large. Hence, segment lengths can be chosen relative to the wavelength in the outer medium.

When the index of refraction of the sheath material is less than that of the surrounding medium, as for air insulation in water, the propagation constant on the wire can be much smaller than in the outer medium. The segments can then be much longer than on a bare wire in that medium. NEC-4 computes the ratio of the complex permittivity in the outer medium to that in the sheath material as

$$R_s = \left| \frac{\epsilon_1 - j\sigma_1/\omega\epsilon_0}{\epsilon_2 - j\sigma_2/\omega\epsilon_0} \right|$$

where ϵ_1 and σ_1 are the relative permittivity and conductivity of the outer medium and ϵ_2 and σ_2 are those for the sheath material. If R_s is greater than 4, the approximate wavenumber of current propagating on the wire is computed using the transmission-line formula from [14]. This value k_s is used as the wavenumber in the sinusoidal current expansion in NEC. Hence, segment lengths can be chosen relative to the wavelength $\lambda_s = 2\pi/k_s$. As for a wire in an

infinite medium, the segment length should be less than about $0.1\lambda_s$. The PS command will cause NEC to print a table of segment lengths relative to λ_s . If PS is followed by EN, The user can check the electrical lengths of segments without executing the remainder of the solution.

The sheath radius is also limited relative to the wavelength in the surrounding medium [15]. For wavenumber k_1 in the outer medium and sheath radius b the limit is about $|k_1 b| < 0.15$. There does not appear to be a limit on the ratio of sheath radius to wire radius.

The NEC model appears to be less accurate for a discontinuous sheath in air than when the sheath covers all of the wire. This was seen in a check of the power balance of input power and radiated power. The code has not been checked for an insulated wire with grounded ends in the earth, so such a situation should be approached with caution. It would probably be safest to use grounding stubs that are $\lambda/4$ long in the medium, so that a charge minimum occurs at the end of the sheath.

3. Program Input

The operation of NEC is controlled by commands read from an input file. The file is usually created by typing commands into an editor, although there are programs that will create the input file after the user defines the model in an interactive graphics session, using devices such as a light pen or digitizer [1]. When NEC is run it asks for the name of the input file and also an output file name. This section of the manual describes all of the input commands and the meanings of the parameters in each command. Users will need to make frequent references to this material in preparing input data for NEC. Although programs such as IGUANA provide assistance and prompting during the generation of model data, users should still be familiar with the various options and restrictions described here.

3.1 Input Format

An input file for NEC consists of one or more data sets separated by NX commands. The file should end with an EN command, although EN may be omitted. Each data set contains two parts. The first part defines the model geometry in terms of wires and surface patches. Once this data is read it remains fixed until the next NX command signals the start of a new data set. The second part of a data set contains commands specifying electrical parameters of the model, setting conditions for the solution and requesting calculations and output. Within each of these two sections there is no strict order for the commands, since each command is identified by a name. However, the commands are read sequentially, and their order determines what conditions are in effect when a calculation is requested.

Previous versions of NEC have required one or more title lines (CM or CE commands) at the beginning of each data set. The text from these commands was printed at the beginning of the output. These lines can still be included, but are optional. CM or CE commands can now be used anywhere in the data set to insert documentation in the output.

All of the input commands other than CM or CE have a similar format. Each starts with a two-letter mnemonic that identifies the command. Next come several integer parameters, and finally floating-point parameters. The input format was developed in an early version of NEC, when commands were usually entered on punched cards. Hence, a fixed pattern is used, with either two or four integer parameters, followed by floating-point numbers. Some commands do not use all of the integer parameters, and zeros must be entered in the unused places. Entering zeros is less convenient than when blanks were simply left in fields on the punched cards, but the format has been left unchanged for compatibility with old data sets.

Data entry on the input commands is close to free format. Numbers can be separated by commas or by one or more spaces. Hence, numbers can be aligned in columns if desired, but this is not necessary. Numbers can be typed in integer, real or exponential form, and they will be converted appropriately. Unused fields following the last data entry can be left blank. However, blanks cannot be used as default for zeros within a data record as was

shown in the NEC-2 manual. The data can begin immediately after the command name or be separated from the name by a comma or spaces. Text can be typed on the end of a command line for documentation if the data is first terminated with an exclamation mark (!). The following examples for the GW command, in which the first two numbers represent integer parameters, are all equivalent:

```
GW 1 7 0 0 -.25 0 0 .25 .001
GW 1 7 0. 0. -.25 0. 0. .25 .001
GW 1 7 0.E0 0.E0 -2.5E-1 0.E0 0.E0 2.5E-1 1.E-3
GW1, 7, 0, 0, -.25, 0, 0, .25, .001
GW,1,7, 0, 0, -.25, 0., 0.E0, .25, 1.E-3    ! Half-wavelength dipole antenna
```

On the commands that cause a file to be read (GF or GN2,...) or cause a file to be written (WG) a name for the file can be entered after the numeric data on the command line. The file name should be separated from the data by a comma or one or more spaces. If no file name is entered, a default name will be used.

3.2 Structure Geometry Input

Data defining the positions of conducting wires and surfaces in an antenna or scatterer are entered in the first part of a NEC data set. This structure definition section is separated from the program control commands by a GE command. For convenient input of structure geometry data, several commands are provided to generate data for groups of segments or patches. Segments may be defined for a straight wire, circular arc, catenary, helix or spiral. Patches may be defined either singly or as multiple patches covering a flat, rectangular plate. In addition, there are commands to shift or rotate all or part of a previously defined structure, either moving the original structure or making multiple copies, with each copy transformed from the previous one.

The ability to shift and rotate previous data is useful for generating arrays or bodies that are symmetric about reflection planes or about an axis of rotation. Sometimes it is convenient to define a planar structure in a coordinate plane and then move it (using a GM command) to the required location. In addition, when a symmetric body is generated by a reflection (GX command) or rotation (GR command) the code will be set to make use of the symmetry to reduce the solution time and the amount of computer memory required. Use of a GX or GR command is the only way to take advantage of symmetry in the solution, since the code does not search for symmetric patterns in the structure. The GX or GR must be the last command generating new segments or patches, since any additional segments or patches entered will destroy the symmetry. However, it is possible to take advantage of partial symmetry by writing a Numerical Green's Function (NGF) file for the symmetric structure, and then adding the unsymmetric parts in a subsequent run using the NGF file. The use of reflections and rotations to generate symmetric structures is demonstrated in the examples at the end of this section, following the command definitions.

The commands for generating wire structures permit the user to assign tag numbers to the segments for later use in referring to a segment; for example, to specify the location of a voltage source or load. The way that tag numbers are used is up to the user. Some may prefer to assign a unique tag number to each wire input, so that the segments associated with a wire can be identified by the tag numbers printed in the output. Otherwise, tags may be assigned only to wires on which voltage sources, loads or network or transmission line connections will be located. Tags do not need to be used at all, since segments can always be referenced by the absolute segment number, determined by the order in which the segments were generated. However, it may be difficult to determine the absolute number of a segment when the structure is large and complex. In such cases the segment may be more easily referenced if it is assigned a tag number. A segment can be identified by its tag number and its number in the set of segments having that tag number. Thus, if a wire is specified in some part of a structure with 7 segments and a tag of 3, then the center segment of the wire could be referred to as tag 3, segment 4.

When a part of a structure is duplicated using a GM, GR or GX command an increment can be specified for the tags so that tag numbers in the new sections do not duplicate numbers in the original section. Segments for which a tag number has not been specified will have tag numbers of zero, and these will not be incremented in the duplication process. In some cases it may be desirable to let tag numbers be repeated without change in the new sections, since a load can then be specified on corresponding wires in each symmetric section by using a single LD command for that tag number.

The format for structure-geometry commands begins with a two letter identifier, followed by two integer parameters and then real or floating-point numbers. In the following descriptions of the commands the integer parameters are referred to as I1 and I2 and the decimal numbers as F1, . . . , F7. Most commands have a maximum of seven decimal numbers, with a continuation command used for additional parameters. New commands (CW) use more decimal numbers on the main command line. The Fortran variable names or useful mnemonics are also given for the parameters when possible.

CM, CE – Text to Document Output

Purpose: To insert text in the program output for a title or documentation.

Command:

CM *Text...*
CE *Text...*

Parameters:

Either CM or CE commands can be used anywhere in the input data to insert documentation into the output. The text from multiple CM or CE commands that are grouped together will be enclosed in a box in the output.

CW – Catenary Wire

Purpose: To generate a wire between two points with the catenary shape of a hanging cable.

Command:

CW	ITG	NS	X1	Y1	Z1	X2	Y2	Z2	RAD	ICAT	RHM	ZM
	I1	I2	F1	F2	F3	F4	F5	F6	F7	F8	F9	F10

Parameters:

- ITG (I1)** – Tag number assigned to all segments of the wire.
NS (I2) – Number of segments into which the wire will be divided.
X1 (F1) – x coordinate of the first end of the wire.
Y1 (F2) – y coordinate of the first end of the wire.
Z1 (F3) – z coordinate of the first end of the wire.
X2 (F4) – x coordinate of the second end of the wire.
Y2 (F5) – y coordinate of the second end of the wire.
Z2 (F6) – z coordinate of the second end of the wire.
RAD (F7) – Wire radius.
ICAT (F8) – Flag to select the mode for defining the catenary.

The functions of the remaining parameters depend on ICAT:

- ICAT = 1** – Specify height at a point along the catenary.
 RHM (F9) – Horizontal distance from the first end (X1,Y1) to a point under the catenary.
 ZM (F10) – Height of the catenary at the point defined by RHM.
- ICAT = 2** – Specify sag at a point along the catenary.
 RHM (F9) – Horizontal distance from the first end (X1,Y1) to a point under the catenary.
 ZM (F10) – Sag of the catenary below a straight-line path at the point defined by RHM.
- ICAT=3** – Specify the total length of the catenary.
 RHM (F9) – Length of the catenary between end points.
 ZM (F10) – Not used.

Additional Information:

- The wire segments are inscribed within the catenary, so the total segment length will be somewhat less than the catenary length. The total length of the catenary is divided into NS equal sections, and a segment subtends each of these sections. Hence, the segments will have nearly equal lengths, but segments on a part of the catenary with greater curvature will be somewhat shorter than on straighter sections. The catenary length and total wire length are printed in the output.
- For ICAT equal to 1 or 2, the height or sag at the point defined by RHM sets the amount of curvature in the catenary. This point should not be too close to either end point, and the height should be less than the height of a straight line between points (X1, Y1, Z1) and (X2, Y2, Z2). If the height is above the straight line, the catenary will turn upside down.
- For ICAT equal to 3, the length set by RHM should be greater than or equal to the straight-line distance between the end points. If a length less than the straight line between the ends is entered, a straight wire between the end points will be generated.
- See the GW command for other information on entering wires.

GA – Wire Arc Specification

Purpose: To generate a circular arc of wire segments. The arc is in the x - z plane, centered on the y axis.

Command:

GA	ITG	NS	RADA	ANG1	ANG2	RAD
I1	I2	F1	F2	F3	F4	

Parameters:

- ITG (I1)** – Tag number assigned to all segments of the wire arc.
- NS (I2)** – Number of segments into which the arc will be divided.
- RADA (F1)** – Arc radius. The center of the arc is at the origin and the axis is the y axis, so the arc is in the x - z plane.
- ANG1 (F2)** – Angle of the first end of the arc measured from the x axis in a left-hand direction about the y axis (degrees).
- ANG2 (F3)** – Angle of the second end of the arc.
- RAD (F4)** – Wire Radius.

Additional Information:

- The segments generated by GA form a section of polygon inscribed within the arc.
- If an arc in a different position or orientation is desired, the segments may be moved with a GM command.
- Use of GA to form a circle will not result in symmetry being used in the calculation. However, GA is a good way to form the beginning of a circle, to be completed by GR.
- See notes for GW.

GC – Continuation Data for Tapered Wire

Purpose: GC contains a continuation of data from the GW command when specifying a wire with varying segment lengths or radius.

Command:

GC	IX	0	RDEL	RAD1	RAD2	DEL1	DEL2
	I1	I2	F1	F2	F3	F4	F5

Note: The integer parameter I2 is not used. A zero should be entered in its position.

Parameters:

- IX (I1)** – Flag to select the input form for tapered segment lengths:
 0 – to specify the ratio of segment lengths (RDEL).
 1 – to specify the length of the first segment (DEL1).
 2 – to specify the lengths of the first and last segments (DEL1 and DEL2).
- RDEL (F1)** – If IX=0, RDEL is the ratio of the length of segment $i + 1$ to the length of segment i . DEL1 and DEL2 are not used in this case and can be omitted.
- RAD1 (F2)** – Radius of the first segment on the wire.
- RAD2 (F3)** – Radius of the last segment on the wire.
- DEL1 (F4)** – If IX=1 or 2, DEL1 is the length of the first segment. The length must be greater than zero and less than the total wire length. For either IX=1 or IX=2 the parameter RDEL is not used, but a zero must be entered to fill its place.
- DEL2 (F5)** – If IX=2, DEL2 is the length of the last segment on the wire. The segment-length ratio and total number of segments will be computed to fill the total wire length. Hence the value entered for NS on the GW command will have no effect.

Additional Information:

- The ratio of the radii of adjacent segments is

$$RRAD = \left(\frac{RAD2}{RAD1} \right)^{1/(NS-1)}$$

- If the total wire length is L and the ratio of the length of segment $i + 1$ to that of segment i is R_{Δ} , then the length of the first segment is

$$\Delta_1 = \frac{L(1 - R_{\Delta})}{1 - R_{\Delta}^{NS}}$$

or

$$\Delta_1 = L/NS \quad \text{if } R_\Delta = 1.$$

When the initial segment length is input (IX=1), the length ratio R_Δ is computed by solving the above equation by iteration. When the initial and final segment lengths are specified (IX=2) the length ratio and number of segments are computed as

$$R_\Delta = \frac{L - \Delta_1}{L - \Delta_2}, \quad N = 1 + \frac{\log(\Delta_2/\Delta_1)}{\log R_\Delta}.$$

N is rounded to an integer. R_Δ is then recomputed to fit the total wire length with the specified initial segment length. The resulting final segment length will differ slightly from the requested value due to rounding N.

GE – End Geometry Input

Purpose: To terminate reading of geometry data and to set parameters to allow subsequent use of a ground plane.

Command:

GE I1 I2

Parameters:

- I1** – Flag to set geometry parameters to allow subsequent use of a ground plane. Options are:
- 0 – no ground plane is present.
 - 1 – indicates a ground plane is present, and wires ending on the ground plane should be connected to the ground. The current will be interpolated to the image of the wire below the ground so that charge is zero at the base of the wire. This option can not be used if wires are buried or penetrate below the ground surface. Also, the structure symmetry option is modified to allow for interaction of the structure with the ground plane.
 - 1 – indicates a ground plane is present. Structure symmetry is modified as required. However, the current expansion is not modified. Thus if a wire ends on the ground plane the current will go to zero at the end.
- I2** – Flag to request a check for illegal segment intersections or severe violations of the thin-wire approximation. Options are:
- 1 – The test is not performed.
 - 0 – (default) Segments are tested and messages printed. Error messages will cause the code to stop.
 - 1 – Error or warning messages will cause the code to stop.
 - 2 – Segments are tested, but the code will continue to run with errors or warnings.

Additional Information:

- The basic function of the GE command is to terminate reading of geometry data commands. In doing this, it causes the program to search through the segment data that have been generated by the preceding commands to determine which wires are connected together. This information is used later in the current expansion.
- At the time that the GE command is read, the structure dimensions must be in units of meters.
- A positive or negative value of I1 does not cause a ground plane to be included in the calculation. It only modifies the geometry data as required when a ground is present.

The ground parameters must be specified on a GN or GR command in the program control section of the data file.

- When $I1 = 1$, no segment may extend below the ground plane (x - y plane) or lie in this plane. Segments may end on the ground plane.
- As an example of how the symmetry of a structure is affected by the presence of a ground plane, consider a structure generated with cylindrical symmetry about the z axis using a GR command. The presence of a ground does not affect the cylindrical symmetry. However, if this same structure is rotated off the vertical, the cylindrical symmetry is lost due to interaction with the ground. As a second example, consider a structure formed by reflection about the x - y plane and then raised above this plane. Interaction with a ground plane destroys the symmetry along the z axis. In general, if the structure has been rotated about the x or y axis by the GM command, all symmetry is lost (i.e. the no-symmetry condition is set.) If the structure was not rotated about the x or y axis, only symmetry about a plane parallel to the x - y plane is lost. Translation of the position of a structure does not affect symmetries.
- When segment testing is requested with the I2 parameter, error messages are printed for illegal segment intersections and warning messages are printed for violations of the thin-wire approximation. An illegal intersection is indicated when the minimum separation of the segments at a point other than at the segment ends is less than 10^{-3} times the length of the shorter of the two segments. A violation of the thin-wire approximation is indicated when the minimum separation of non-connected segments is less than the sum of their radii. A warning message is also printed if the center of a segment is within the volume of another segment.

GF – Read a NGF File

Purpose: To read a previously written NGF file.

Command:

GF I1 [File Name]

Parameters:

I1 – Print a table of the coordinates of the ends of all segments in the NFG file if I1 \neq 0.
Normal printing otherwise.

Additional Information:

- GF must be the first command in the structure geometry section except for CM or CE.
- The table with coordinates of segment ends is useful in connecting new wires to a structure from the NGF file.
- A name for the Numerical Green's Function file can be entered after the data on the GF command, separated from the data by spaces or a comma. If no file name is entered, the default file name of NGFS.NEC will be used
- The effects of some other commands are altered with a GF command is used. See section 3.6.

GH – Wire Helix or Spiral

Purpose: To generate a wire helix or a log or Archimedes spiral.

Command:

GH	ITG	NS	TURNS	ZLEN	HR1	HR2	WR1	WR2	ISPX
I1	I2	F1	F2	F3	F4	F5	F6	F7	

Parameters:

- ITG (I1)** – Tag number assigned to all segments of the spiral.
- NS (I2)** – Number of segments in the spiral.
- TURNS (F1)** – Number of turns in the spiral (may be fractional.) A positive number will produce a right-hand helix relative to the positive z axis, and a negative number will produce a left-hand helix.
- ZLEN (F2)** – Length of the spiral or helix along the z axis. The helix starts at $z = 0$ and ends at $z = ZLEN$.
- HR1 (F3)** – Radius of the spiral at the starting end. The wire starts at $x = HR1$ and $y = z = 0$.
- HR2 (F4)** – Radius of the helix at the final end. HR2 may be greater or less than HR1. If $HR2 = 0$, it will be set equal to HR1.
- WR1 (F5)** – Radius of the wire at the starting end of the spiral.
- WR2 (F6)** – Radius of the wire at the final end of the spiral. If $WR2 = 0$, it will be set equal to WR1. Segment radii are scaled logarithmically along the wire.
- ISPX (F7)** – 0 for a log spiral ($r = r_1 a^\theta$); =1 for an Archimedes spiral ($r = r_1 + a\theta$). Either can be used for a helix with $HR1 = HR2$.

Additional Information:

- The segments generated by GH subtend equal angles with respect to the z axis. The segments are inscribed within the curve of the spiral.
- If a spiral in a different position or orientation is desired, the segments may be moved with a GM command.
- See notes for GW.

GM – Coordinate Transformation

Purpose: To translate or rotate a structure with respect to the coordinate system or to generate new structures translated or rotated from the original.

Command:

GM	ITGI	NRPT	ROX	ROY	ROZ	XS	YS	ZS	IT1	IS1	IT2	IS2
	I1	I2	F1	F2	F3	F4	F5	F6	F7	F8	F9	F10

Parameters:

- ITGI (I1)** – Tag number increment.
- NRPT (I2)** – The number of new structures to be generated.
- ROX (F1)** – Angle in degrees through which the structure is rotated about the *x*-axis. A positive angle causes a right-hand rotation.
- ROY (F2)** – Angle of rotation about the *y*-axis in degrees.
- ROZ (F3)** – Angle of rotation about the *z*-axis in degrees.
- XS (F4)** – Amount by which the structure is shifted in the *x* direction.
- YS (F5)** – Amount by which the structure is shifted in the *y* direction.
- ZS (F6)** – Amount by which the structure is shifted in the *z* direction.
- IT1 (F7)** – Parameters IT1 and IS1 define the first segment in a range of segments that will be moved or duplicated. IT1 is the tag number defining the first segment. If IT1 and IS1 are zero the operation will start with segment 1, or if a NGF file is in use with the first segment after the NGF section. If IT1 through IS2 are omitted, all segment will be moved or duplicated.
- IS1 (F8)** – Segment number of the first segment in the range, counting only segments with tag IT1. If IT1 is zero, IS1 refers to the absolute segment number. If IS1 is zero but IT1 is not zero, IS1 is set equal to 1.
- IT2 (F9)** – Tag number defining the last segment in the range. If IT2 and IS2 are zero the range extends to the last segment presently defined.
- IS2 (F10)** – Segment number of the last segment in the range, counting only segments with tag IT2. If IT2 is zero, IS2 refers to the absolute segment number. If IT2 is non-zero and IS2 is zero, IS2 is set equal to 1.

Additional Information:

- If NRPT is zero, the structure is moved by the specified rotation and translation leaving nothing in the original location. If NRPT is greater than zero, the original structure remains fixed and NRPT new structures are formed, each shifted from the previous one by the requested transformation.

- The tag increment, ITGI, is used when new structures are generated (NRPT greater than zero) to avoid duplication of tag numbers. Tag numbers of the segments in each new copy of the structure are incremented by ITGI from the tag on the previous copy or original. Tags of segments which are generated from segments having no tags (tag equal to zero) are not incremented. Generally, ITGI will be greater than or equal to the largest tag number used on the original structure to avoid duplication of tags. For example, if the tag numbers 1 through 100 have been used before a GM command is read having NRPT equal to 2, then ITGI equal to 100 will cause the first copy of the structure to have tags from 101 to 200 and the second copy from 201 to 300. If NRPT is zero, the tags on the original structure will be incremented.
- The result of a transformation depends on the order in which the rotations and translation are applied. The order used is first rotation about the x axis, then rotation about the y axis, then rotation about the z axis and, finally, translation by (XS, YS, ZS). All operations refer to the fixed coordinate system axes. If a different order is desired, separate GM commands may be used.

GR – Generate Cylindrical Structure

Purpose: To reproduce a structure while rotating about the z axis to form a complete cylindrical array, and to set flags so that symmetry is utilized in the solution.

Command:

```
GR  ITGI  NR
      I1   I2
```

Parameters:

ITGI (I1) – Tag number increment.

NS (I2) – Total number of times that the structure is to occur in the cylindrical array.

Additional Information:

- The tag increment ITGI is used to avoid duplication of tag numbers in the reproduced structures. In forming a new structure for the array, all valid tags on the previous copy or original structure are incremented by ITGI. Tags equal to zero are not incremented.
- The GR command should never be used when there are segments on the z axis or crossing the z axis since overlapping segments would result.
- The GR command sets flags so that the program makes use of cylindrical symmetry in solving for the currents. If a structure modeled with N segments has M sections in cylindrical symmetry (formed by a GR command with I2 equal to M), the number of complex numbers in matrix storage and the proportionality factors for the time to fill and factor the matrix are:

	Matrix Storage	Fill Time	Factor Time
No Symmetry	N^2	N^2	N^3
M Symmetric Sections	N^2/M	N^2/M	N^3/M^2

The matrix factor time represents the optimum for a large matrix factored in core. Generally, somewhat longer times will be observed.

- If the structure is added to or modified after the GR command in such a way that cylindrical symmetry is destroyed, the program must be reset to a no-symmetry condition. In most cases, the program is set by the geometry routines for the existing symmetry. Operations that automatically reset the symmetry conditions are:
 - Addition of a wire or patch (GW, GH, CW, SP, etc.) will destroy all symmetry.

- Generation of additional structures by a GM command, with NRPT greater than zero, destroys all symmetry.
- A GM command acting on only part of the structure (having ITS greater than zero) destroys all symmetry.
- A GX or GR command will destroy all previously established symmetry while establishing a new symmetric pattern.
- If a structure is rotated about either the x or y axis by use of a GM command, and a ground plane is specified on the GE command, all symmetry will be destroyed. Rotation about the z axis or translation will not affect symmetry. If a ground is not specified, symmetry will be unaffected by any rotation or translation by a GM command, unless NRPT or ITS on the GM command is greater than zero.
- Symmetry will also be destroyed if lumped loads are placed on the structure in an unsymmetric manner. In this case, the program is not automatically set to a no-symmetry condition but must be set by a command following GR. A GW command with NS equal to zero will set the program to a no-symmetry condition without modifying the structure. The GW command must specify a nonzero radius, however, so that the program does not attempt to read a GC command.
- Placement of nonradiating networks or sources does not affect symmetry. When it is necessary to place an unsymmetric load on an otherwise symmetric structure, symmetry can still be used in the solution if the load is introduced with a NT command having appropriate parameters. For example, a network with $Y_{11} = 1/Z_{LOAD}$, $Y_{12} = 0$ and $Y_{22} = 1.E10$ can be connected with port one on the segment to be loaded and port two on any other convenient segment.
- When symmetry is used in the solution, the number of symmetric sections (I2) is limited by array dimensions. In the demonstration program, the limit is 16 sections.
- The GR command produces the same effect on the structure as a GM command if I2 on the GR command is equal to (NRPT+1) on the GM command and if ROZ on the GM command is equal to $360/(NRPT+1)$ degrees. However, if the GM command is used the program will not be set to take advantage of symmetry.

GS – Scale Structure Dimensions

Purpose: To scale all dimensions of a structure by a constant factor.

Command:

```
GS  0  0  FSCALE  
    I1 I2   F1
```

Note: The first two integer parameters are not used. Zeros should be entered in these positions.

Parameters:

FSCALE (F1) – All structure dimensions, including the wire radius, are multiplied by FSCALE.

Additional Information:

- At the end of geometry input, structure dimensions must be in units of meters. Hence, if the dimensions have been input in other units, a GS command must be used to convert to meters.

GW – Straight Wire Specification

Purpose: To generate a straight wire as a string of uniform segments. A wire with tapered radius or segment lengths can also be formed by using GW together with the GC command.

Command:

GW	ITG	NS	XW1	YW1	ZW1	XW2	YW2	ZW2	RAD
	I1	I2	F1	F2	F3	F4	F5	F6	F7

Parameters:

- ITG (I1)** – Tag number assigned to all segments of the wire.
NS (I2) – Number of segments into which the wire will be divided.
XW1 (F1) – x coordinate of the first end of the wire.
YW1 (F2) – y coordinate of the first end of the wire.
ZW1 (F3) – z coordinate of the first end of the wire.
XW1 (F4) – x coordinate of the second end of the wire.
YW1 (F5) – y coordinate of the second end of the wire.
ZW1 (F6) – z coordinate of the second end of the wire.
RAD (F7) – Wire radius, or zero for tapered segment option.

Additional Information:

- The tag number ITG is for later use when a segment must be identified, such as when connecting a voltage source or lumped load to the segment. If no need is anticipated for a reference to the segments of a wire ITG can be zero. Any number except zero can be used as a tag. When identifying a segment by its tag, the tag number and the number of the segment in the set of segments having that tag are given. Thus, the tag of a segment does not need to be unique.
- If two wires are electrically connected at their ends, the identical coordinates should be used for the connected ends to ensure that the wires are treated as connected for current interpolation. If wires intersect away from their ends, the point of intersection must occur at segment ends within each wire for interpolation to occur. Generally, wires should intersect only at their ends unless the location of segment ends is accurately known.
- The only significance of differentiating end one from end two of a wire is that the positive reference direction for current will be in the direction from end one to end two on each segment making up the wire.
- See section 2 for guidelines relating to the choice of segment lengths and radius.
- If the input parameters on the GW command are in units other than meters, then the structure must be scaled to meters through use of a GS command.

GX – Reflect Structure in Coordinate Planes

Purpose: To form structures having planes of symmetry by reflecting part of the structure in the coordinate planes, and to set flags so that symmetry is used in the solution.

Command:

```
GX  ITGI  IXYZ
      I1    I2
```

Parameters:

ITGI (I1) – Tag number increment.

IXYZ (I2) – This entry is divided into three independent digits which control reflection in the three orthogonal coordinate planes. If the first digit is one (1) the structure is reflected along the x axis (in the y - z plane); if the second digit is one (1) the structure is reflected along the y axis (in the x - z plane) and if the third digit is one (1) the structure is reflected along the z axis (in the x - y plane.) A zero for any of the digits causes the corresponding reflection to be omitted.

Additional Information:

- Any combination of reflections along the x , y and z axes may be used. For example, $IXYZ = 101$ will cause reflection along the axes x and z , resulting in 4 times the original number of segments; while $IXYZ = 111$ will cause reflection along axes x , y and z , resulting in 8 times the original number of segments. When combinations of reflections are requested, the reflections are done in reverse alphabetical order. That is, if a structure is generated in a single octant of space and a GX command is then read with $IXYZ = 111$, the structure is first reflected along the z axis; the structure and its image are then reflected along the y axis; and finally, these four copies are reflected along the x axis to fill all octants. This order determines the position of a segment in the sequence and, hence the absolute segment numbers.
- The tag increment ITGI is used to avoid duplication of tag numbers in the image segments. All valid tags on the original structure are incremented by ITGI on the image. When combinations of reflections are employed, the tag increment is doubled after each reflection. Thus, a tag increment greater than or equal to the largest tag on the original structure will ensure that no duplicate tags are generated. For example, if tags from 1 to 100 are used on the original structure with $IXYZ$ equal to 011 and tag increment of 100, the first reflection, along the z axis, will produce tags from 101 to 200; and the second reflection, along the y axis will produce tags from 201 to 400, as a result of the increment being doubled to 200.

- The GX command should never be used when there are segments located in the plane about which reflection would take place or crossing this plane. The image segments would then coincide with or intersect the original segments, and such overlapping segments are not allowed. However, segments may end on the reflection plane, and will connect to their images.
- When a structure having plane symmetry is formed by a GX command, the program will make use of the symmetry to simplify solution for the currents. The number of complex numbers in matrix storage and the proportionality factors for matrix fill time and matrix factor time for a structure modeled by N segments are:

No. of Planes of Symmetry	Matrix Storage	Fill Time	Factor Time
0	N^2	N^2	N^3
1	$N^2/2$	$N^2/2$	$N^3/4$
2	$N^2/4$	$N^2/4$	$N^3/16$
3	$N^2/8$	$N^2/8$	$N^3/64$

The matrix factor time represents the optimum for a large matrix factored in core. Generally, somewhat longer times will be observed.

- If the structure is added to or modified after the GX command in such a way that symmetry is destroyed, the program must be reset to a no-symmetry condition. In most cases, the program is set by the geometry routines for the existing symmetry. Operations that automatically reset the symmetry conditions are:
 - Addition of a wire or patch (GW, GH, CW, SP, etc.) will destroy all symmetry.
 - Generation of additional structures by a GM command, with NRPT greater than zero, destroys all symmetry.
 - A GM command acting on only part of the structure (having ITS greater than zero) destroys all symmetry.
 - A GX or GR command will destroy all previously established symmetry. For example, two GX commands with IXYZ equal to 011 and 100, respectively, will produce the same structure as a single GX command with IXYZ equal to 111; however, the first case will set the program to use symmetry about the y - z plane only while the second case will make use of symmetry about all three coordinate planes.
 - If a ground plane is specified on the GE command, by I1 equal to 1 or -1 , symmetry about a plane parallel to the x - y plane will be destroyed. Symmetry about other planes will be used, however. This adjustment will be taken care of automatically if the value of I1 on the GE command is set properly.

GX

- If a structure is rotated about either the x or y axis by use of a GM command and a ground plane is specified on the GE command, all symmetry will be destroyed. Rotation about the z axis or translation will not affect symmetry. If a ground is not specified, rotation or translation will have no effect on symmetry conditions unless NRPT on the GM command is greater than zero.
- Symmetry will also be destroyed if lumped loads are placed on the structure in an unsymmetric manner. In this case, the program is not automatically set to a no-symmetry condition but must be set by a command following GX. A GW command with NS equal to zero will set the program to a no-symmetry condition without modifying the structure. The GW command must specify a non-zero radius, however, so that the program does not attempt to read a GC command.
- Placement of nonradiating networks or sources does not affect symmetry. When it is necessary to place an unsymmetric load on an otherwise symmetric structure, symmetry can still be used in the solution if the load is introduced with a NT command having appropriate parameters. For example, a network with $Y_{11} = 1/Z_{LOAD}$, $Y_{12} = 0$ and $Y_{22} = 1.E10$ can be connected with port one on the segment to be loaded and port two on any other convenient segment.
- When symmetry is used in the solution, the number of symmetric sections (I2) is limited by array dimensions. In the demonstration program, the limit is 16 sections.

SM, SC – Multiple Patch Surface

Purpose: To cover a rectangular region with surface patches. The SC command must be used following the SM command to enter additional parameters.

Command:

```

1:      SM  NX  NY  X1  Y1  Z1  X2  Y2  Z2
          I1  I2  F1  F2  F3  F4  F5  F6

2:      SC   0   0  X3  Y3  Z3
          I1  I2  F1  F2  F3

```

Note: The first two integer parameter on the SC command are not used. Zeros should be entered in these positions.

Parameters:

On the SM command:

NX (I1) – Number of patches in width (from corner 1 to corner 2)

NY (I2) – Number of patches in height (from corner 2 to corner 3)

X1 (F1) – x coordinate of corner 1

Y1 (F2) – y coordinate of corner 1

Z1 (F3) – z coordinate of corner 1

X2 (F4) – x coordinate of corner 2

Y2 (F5) – y coordinate of corner 2

Z2 (F6) – z coordinate of corner 2

and on the SC command:

X3 (F1) – x coordinate of corner 3

Y3 (F2) – y coordinate of corner 3

Z3 (F3) – z coordinate of corner 3

Additional Information:

- The division of the rectangle into patches is as illustrated in Figure 7.
- The direction of the outward normals $\hat{\mathbf{n}}$ of the patches is determined by the ordering of corners 1, 2 and 3 and right-hand rule. The vectors $\hat{\mathbf{t}}_1$ are parallel to the side from corner 1 to corner 2 and $\hat{\mathbf{t}}_2 = \hat{\mathbf{n}} \times \hat{\mathbf{t}}_1$. The patch may have arbitrary orientation.
- Multiple SC commands are not allowed with SM.

SM

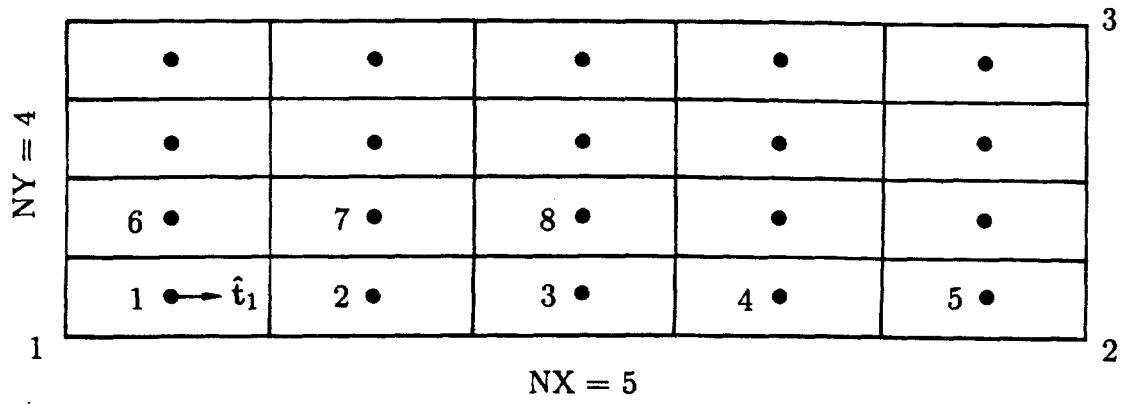

Fig. 7. Rectangular surface covered by multiple patches specified with a SM command.

SP – Surface Patch

Purpose: To input parameters of a single surface patch. For some patch options the SC command must be used following SP to enter additional parameters.

Command:

```

1:      SP  0  NS  X1  Y1  Z1  X2  Y2  Z2
          I1  I2  F1  F2  F3  F4  F5  F6

2:      SC  0  0  X3  Y3  Z3  X4  Y4  Z4
          I1  I2  F1  F2  F3  F4  F5  F6

```

Note: The first integer parameter on the SP command and the first two integers on the SC command are not used. Zeros should be entered in these positions.

Parameters:

NS (I2) – Selects the option for defining the patch as follows:

- 0 – shapeless patch description – center point, normal, area
- 1 – rectangular patch
- 2 – triangular patch
- 3 – quadrilateral patch

The use of the remaining parameters varies with the value of NS.

NS = 0 is the “shapeless” patch description. The patch is defined by its center point, the outward pointing normal vector and patch area as follows:

X1 (F1) – x coordinate of the patch center
Y1 (F2) – y coordinate of the patch center
Z1 (F3) – z coordinate of the patch center
X2 (F4) – elevation angle of the outward normal vector above the x - y plane (degrees).
Y2 (F5) – azimuth angle of the outward normal vector from the x axis (degrees).
Z2 (F6) – patch area (square of units used)

For the rectangular, triangular or quadrilateral patch definition (NS = 1, 2 or 3 respectively) the patch is defined by the coordinates of its corners. The input parameters are then:

X1 – x coordinate of corner 1
Y1 – y coordinate of corner 1
Z1 – z coordinate of corner 1
X2 – x coordinate of corner 2
Y2 – y coordinate of corner 2
Z2 – z coordinate of corner 2
X3 – x coordinate of corner 3

Y3 – y coordinate of corner 3

Z3 – z coordinate of corner 3

X4 – x coordinate of corner 4

Y4 – y coordinate of corner 4

Z4 – z coordinate of corner 4

The coordinates for corner 4 are used only in the quadrilateral patch description ($NS = 3$).

Additional Information:

- The four patch description options are shown in Figure 8. For the rectangular, triangular and quadrilateral patches the outward normal vector $\hat{\mathbf{n}}$ is determined by the ordering of corners 1, 2 and 3 and the right-hand rule.
- For a rectangular, triangular or quadrilateral patch, $\hat{\mathbf{t}}_1$ is parallel to the side from corner 1 to corner 2. For $NS = 0$, $\hat{\mathbf{t}}_1$ is chosen as described in section 2.5.
- If the sides from corner 1 to corner 2 and from corner 2 to corner 3 of the rectangular patch are not perpendicular, the result will be a parallelogram.
- If the four corners of the quadrilateral patch do not lie in the same plane, the run will terminate with an error message.
- Since the program does not integrate over patches, except at a wire connection, the patch shape does not affect the results. The only parameters affecting the results are the location of the patch centroid, the patch area and the outward unit normal vector. For a shapeless patch these are the input quantities, while for the other options they are determined from the specified shape. However, for solution accuracy, the distribution of patch centers obtained with generally square patches has been found to be desirable (see Section 2.5).
- For the rectangular or quadrilateral options, multiple SC commands may follow a SP command to specify a string of patches. The parameters on the second or subsequent SC command specify corner 3 for a rectangle or corners 3 and 4 for a quadrilateral, while corners 3 and 4 of the previous patch become corners 2 and 1, respectively, of the new patch. The integer I2 on the second or subsequent SC command specifies the new patch shape and must be 1 for rectangular shape or 3 for quadrilateral shape. On the first SC command after SP, I2 has no effect. Rectangular or quadrilateral patches may be intermixed, but triangular or shapeless patches are not allowed in a string of linked patches.

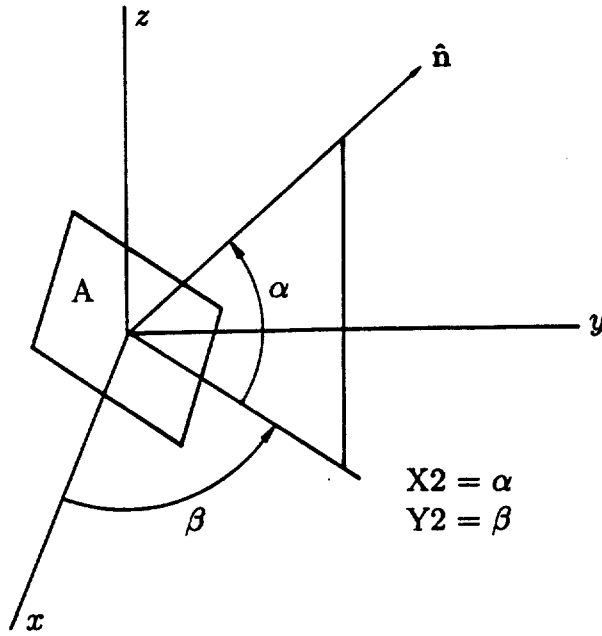

a) Patch defined by center point, normal and area.

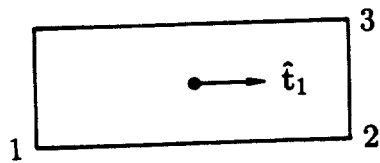

b) Rectangular patch (NS = 1)

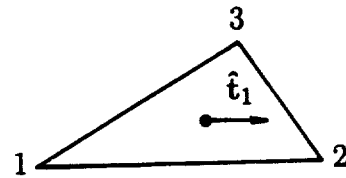

c) Triangular patch (NS = 2)

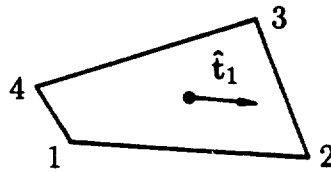

d) Quadrilateral patch (NS = 3)

Fig. 8. Rectangular surface covered by multiple patches specified with a SM command.

3.3 Program Control Commands

The program control commands follow the GE command that ends the structure geometry input in a data set. They define the electrical parameters for the model, select options for the solution and request data computation and output. The commands are listed below by their identifier codes with a brief description of their function, and grouped according to whether they affect the entire solution (I), affect the current but not the MoM matrix (II) or only affect results derived from the current (III):

I	{	FR	- frequency specification
		GN	- ground parameters
		IS	- insulating sheath
		JN	- condition on charge at a junction
		LD	- structure impedance loading
		UM	- upper-medium parameters
		VC	- voltage-source end caps
II	{	EX	- structure excitation
		NT	- two-port network
		TL	- transmission line specification
III	{	CP	- maximum-coupling calculation
		EN	- end of input file
		GD	- additional ground parameters
		LE	- near electric field along a line
		LH	- near magnetic field along a line
		NE	- near electric field point array
		NH	- near magnetic field point array
		NX	- next input data set
		PQ	- printing options for charge on wires
		PS	- print electrical lengths of segments
		PT	- printing options for current on wires
		RP	- radiated field and antenna gain request
		WG	- write Numerical Green's Function file
XQ	- execute to compute currents only		

There is no fixed order for the commands. However, they are read sequentially, so the result of a solution will be affected only by the commands preceding the solution request. Parameters that are not set before a solution request will be given default values, with the exception that an EX command must be included for a non-zero excitation. The default for frequency is 299.8 MHz ($\lambda = 1$ m), while for most other commands the item affected is omitted without the command.

All parameters retain their values until changed by subsequent commands. Hence, after parameters have been set and currents or fields computed, selected parameters may be changed and the calculations repeated. For example, if a number of different excitations are required at a single frequency, the data set could have the form FR, EX, XQ, EX, XQ, . . . If a single excitation is required at a number of frequencies, the commands EX, FR, XQ, FR, XQ, . . . could be used.

An important point to remember in such repeated calculations is that the program repeats only those parts of the solution that are affected by the changed parameters. The first step in the solution is to calculate the MoM interaction matrix and factor it in preparation for the solution for currents. The next step is to solve for the currents for a given excitation. Finally, the near fields or radiated fields are computed from the currents. The most time consuming steps in the solution process are filling and factoring the interaction matrix, which require times proportional to $(N + M)^2$ and $(N + M)^3$, respectively, for N segments and M patches. Computing the currents requires a time proportional to $(N + M)^2$, but is much faster than filling the matrix. The time to compute a field value from the current is proportional to $N + M$, so is minor unless many field values are computed.

The interaction matrix depends only on the structure geometry and the parameters in group I of the program control commands. Thus, computation and factoring of the matrix is not repeated if parameters beyond group I are changed. Antenna currents depend on both the interaction matrix and the commands in group II. Hence currents must be recomputed whenever parameters from group I or II are changed. The near fields depend only on the structure currents, while the radiated fields depend on the currents and on parameters from the GD command. To minimize computation time for a sequence of solutions, all parameter changes in a lower group should be made before any changes in a higher group. This rule is illustrated by the following two sequences of commands:

```
FR, EX, NT1, LD1, XQ, LD2, XQ, NT2, LD1, XQ, LD2, XQ
FR, EX, LD1, NT1, XQ, NT2, XQ, LD2, NT1, XQ, NT2, XQ
```

Since LD is a group I command while NT is in group II, filling and factoring of the matrix would be required four times by the first sequence but only twice by the second in obtaining the same information. The code does not repeat solution steps unnecessarily. Hence the commands RP or (XQ, RP) or (RP, XQ) are all equivalent.

The format for program control commands begins with a two letter identifier, followed by four integers and then up to six floating-point numbers. In the command descriptions the integer parameters are labeled I1, I2, I3 and I4; while the floating-point numbers are F1, . . . , F6. The Fortran variable names or useful mnemonics are also given for the parameters when possible.

CP – Maximum Coupling Calculation

Purpose: To request calculation of the maximum coupling between sources on two segments.

Command:

CP	TAG1	SEG1	TAG2	SEG2
	I1	I2	I3	I4

Parameters:

- TAG1 (I1)** – Tag number specifying the first segment of the two segments for the coupling calculation
- SEG1 (I2)** – Number of the first segment, counting only segments having tag TAG1. If TAG1 is zero, SEG1 is the absolute segment number.
- TAG2 (I3)** – Tag number specifying the second segment of the two segments for the coupling calculation.
- SEG2 (I4)** – Number of the second segment, counting only segments having tag TAG2. If TAG2 is zero, SEG2 is the absolute segment number.

Additional Information:

- The operation of the CP command differs from that in NEC-3 and earlier codes. In NEC-4 the CP command causes immediate execution of the solution, while NEC-3 waited for EX commands to excite each segment. NEC-4 should give the correct maximum coupling when the structure includes networks and transmission lines, while NEC-3 did not.
- When the CP command is read it causes immediate calculation of the coupling between the two specified segments. Hence, the MoM matrix will be evaluated and factored, if this has not already been done. The specified segments will then be excited one at a time, with the other segment short circuited, in order to compute the self and mutual admittances. However, the currents resulting from this solution will not be printed. If a printout of the currents or radiation patterns is needed the segments must be excited in a separate step with an EX command.

EN – End of Run

Purpose: To mark the end of the data file and terminate execution of the program.

Command:

EN

Parameters: none

EX – Structure Excitation

Purpose: To specify the excitation for the structure. The excitation can be voltage sources, incident plane waves, a current-element source or a combination of these.

Command:

EX I1 I2 I3 I4 F1 F2 F3 F4 F5 F6 F7

Parameters:

- I1** – Determines the type of excitation that is used. The options are:
- 0 – voltage source (applied-E-field source).
 - 1 – incident plane wave, linear polarization.
 - 2 – incident plane wave, right-hand (thumb along the incident \hat{k} vector) elliptic polarization.
 - 3 – incident plane wave, left-hand elliptic polarization.
 - 4 – current-element source.
 - 5 – voltage source (bicone source model).

The functions of the remaining parameters depend on the excitation type:

- I1 = 0 or 5** – Voltage Source (I1 = 0 for applied field or 5 for bicone.)
- I2** – Tag number used along with parameter I3 to specify the source segment.
 - I3** – Number of the source segment in the set of segments having tag number I2. If I2 is zero then I3 is the absolute segment number of the source segment.
 - I4** – 1 to request that input impedances be collected over a frequency loop and printed in a special format; I4 = 0 otherwise. The impedances will be printed in ohms and also normalized by either the maximum value or a factor specified by the parameter F3.
 - F1** – Real part of the source voltage in volts.
 - F2** – Imaginary part of the source voltage in volts.
 - F3** – Normalization factor for impedance when I4 = 1. If F3 is zero and I4 = 1, the impedances are normalized by their maximum magnitude.

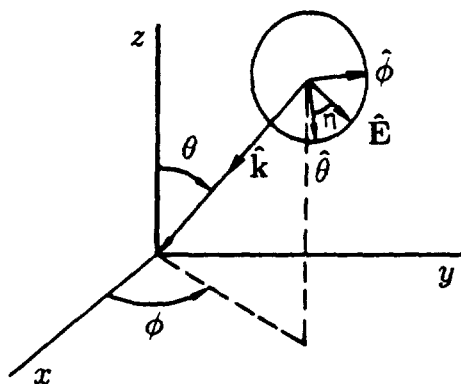

Fig. 9 Specification of an incident plane wave. The direction of the incoming wave vector $\hat{\mathbf{k}}$ is determined by θ and ϕ , and the polarization angle between $\hat{\mathbf{E}}$ and $\hat{\boldsymbol{\theta}}$ is η .

I1 = 1,2,3 – Incident plane wave. The incident wave is characterized by the direction of incidence $\hat{\mathbf{k}}$ and the polarization in the plane normal to $\hat{\mathbf{k}}$ as shown in figure 9. Parameters are:

- I2** – Number of θ angles requested in a loop over incidence angles.
- I3** – Number of ϕ angles requested in a loop over incidence angles.
- I4** – Not used.
- F1** – The angle θ (degrees) to the incident vector $\hat{\mathbf{k}}$ in standard spherical coordinates.
- F2** – The angle ϕ (degrees) to the incident vector $\hat{\mathbf{k}}$ in standard spherical coordinates.
- F3** – The polarization angle η (degrees) between the $\hat{\boldsymbol{\theta}}$ unit vector and the incident electric field. For elliptical polarization F3 specifies the major ellipse axis for \mathbf{E} .
- F4** – Stepping increment for θ in a loop over incidence angles.
- F5** – Stepping increment for ϕ in a loop over incidence angles.
- F6** – Ratio of minor axis to major axis for elliptic polarization.
- F7** – Magnitude of electric field in the incident wave (along major axis for elliptic polarization.) The default is 1 V/m if $F7 = 0$.

I1=4 – Current element source. The structure is illuminated by the field of an elementary current source with the position and orientation specified.

- I2 – I4** – Not used.
- F1** – x position of the current element in meters.
- F2** – y position of the current element in meters.
- F3** – z position of the current element in meters.
- F4** – The angle α (degrees) between the x - y plane and the current element, as illustrated in figure 10.
- F5** – The angle β (degrees) between the x axis and the projection of the current element on the x - y plane.
- F6** – Current moment of the source, $I\ell$, in amp meters.

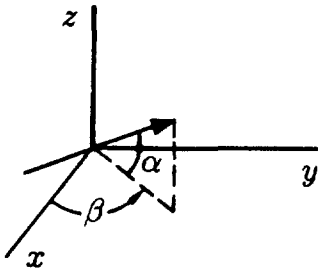

Fig. 10 Orientation of the current element source.

Additional Information:

- The applied-E-field voltage source is located on the segment specified. Guidelines for accurate source modeling are reviewed in section 2.3.
- The bicone voltage source is located at the first end of the specified segment, at the junction with the previous segment. This junction must be a simple two-segment junction with the segments collinear and with equal radii. The bicone source is not accurate unless the wire is very thin and the Δ/a of the segment is reasonably large (see section 2.3) The applied-field source should be used for most applications.
- A bicone source may lie in a symmetry plane at the junction between segments. An applied-field source cannot lie in a symmetry plane, since a segment cannot cross a symmetry plane. A source centered on a symmetry plane can be modeled with the applied-field source by exciting two segments on opposite sides of the plane, each with half of the total source voltage. The sign of each voltage source must take into account the opposing reference directions of the segments if one segment was generated by reflecting the other.
- An applied-field voltage source specified on a segment which has been loaded (LD command) is connected in series with the load. An applied-field source on the same segment as a network or transmission line is connected in parallel with the network or transmission line port. For a transmission line, the source is in parallel with both the line and any shunt load specified on the TL command. Bicone voltage sources should not be used in combination with loads or network connections.
- Several EX commands can be grouped together to specify multiple sources of excitation. Normally one or more voltage sources will be used on a transmitting antenna, and a single incident wave, with a range of angles, will be defined for receiving antennas or scatterers. If necessary, voltage sources and one or more incident plane waves and current-element sources may be combined. When mixed source types are used, the last source in the group of EX commands will determine the output format. If the last EX command

specifies a voltage source, the output will show source parameters (input impedance and power) and antenna gains. These values will be altered by any incident plane waves as if by interference in a measurement situation. If the last source specified is an incident plane wave, the voltage source parameters will not be printed, and radiation patterns will show scattering cross sections σ/λ^2 .

- Looping over angles for an incident plane wave works only for the last EX command in a group.
- When looping over both θ and ϕ angles is specified for an incident plane wave, the θ angle changes more rapidly than ϕ .

FR – Set Frequencies

Purpose: To specify the frequency(s) in megahertz.

Command:

FR	IFRQ	NFRQ	0	0	FMHZ	DELFRQ
	I1	I2	I3	I4	F1	F2

Note: The integer parameters I3 and I4 are not used. Zeros should be entered in these positions.

Parameters:

- IFRQ (I1)** – Determines the type of frequency stepping that is used. The options are:
 0 – linear stepping.
 1 – multiplicative stepping.
- NFRQ (I2)** – Number of frequency steps.
- FMHZ (F1)** – Frequency in MHz or starting frequency in a range.
- DELFRQ (F2)** – Frequency stepping increment. If the frequency stepping is linear (IFRQ = 0), this quantity is added to the initial frequency NFRQ–1 times. If the stepping is multiplicative, this is the multiplication factor.

Additional Information:

- If a FR command does not appear in the data deck, a single frequency of 299.8 MHz is used. Since the wavelength at 299.8 MHz is one meter, the units for the geometry are then equivalent to wavelengths.
- Frequency commands may not be grouped together. If they are, only the information on the last FR command before execution will be used.
- After a FR command with NFRQ greater than 1, an NE or NH command will not initiate execution. The code waits for either a RP or XQ command so that both near field and radiated field evaluations can be requested in the loop. However, only one near field command, either NE or NH, and one RP command can be included in the loop.
- After a frequency loop for NFRQ greater than one has been completed, it will not be repeated for a second execution request. The FR command must be entered again to repeat the loop.

GD – Additional Ground Parameters

Purpose: To specify the ground parameters of a second medium which is not in the immediate vicinity of the antenna. This command may only be used if a GN command has also been entered.

Command:

GD	ICLIF	0	0	0	EPSR2	SIG2	CLT	CHT
I1	I2	I3	I4	F1	F2	F3	F4	

Note: Parameters I2, I3 and I4 are not used. Zeros should be entered in these positions.

Parameters:

- ICLIF (I1)** – 1 for a linear boundary between media 1 and 2, at a distance CLT; =2 for a circular boundary at a radius of CLT; =0 for no second medium.
- EPSR2 (F1)** – Relative dielectric constant of the second medium.
- SIG2 (F2)** – Conductivity of the second medium in S/m.
- CLT (F3)** – Distance in meters from the origin of the coordinate system to the boundary between media 1 and 2. This distance is either the radius of the circle where the two media join (ICLIF=2) or the distance out the x axis to the linear boundary (ICLIF=1).
- CHT (F4)** – Distance in meters (positive or zero) by which the surface of medium 2 is below medium 1.

Additional Information:

- GD works differently in NEC-4 than in previous versions of NEC. In earlier versions a flag had to be set on the RP command to cause the conditions set by the GD command to be included in the radiated field calculation and to select the linear or circular boundary. In NEC-4 the conditions set by GD are automatically included in the RP calculation. Also, in NEC-4 the second medium will affect the radiated field due to patches, while it did not in previous versions of NEC.
- In computing radiated field in a given direction, NEC determines the point on the first or second medium where the ray from each segment or patch reflects, and uses the appropriate ground parameters and height of the ground in computing the reflected ray. Diffraction from the cliff edge is not included.
- When the ground wave is computed (RP 1), the second-medium parameters from a GD command have no effect. The surface wave can only be computed for an infinite flat ground with the primary ground parameters.

GD

- The GD command can only be used in a data set where the GN command has been entered, since GN is the only way to specify the ground parameters in the vicinity of the antenna.
- Only one GD command is effective at a time. Multiple cliffs are not allowed.
- The second-medium parameters affect only the radiated field, and not the near fields (NE or NH) or the calculation of currents. If the segments and patches extend out over the second medium the currents will still be computed for the structure over the primary medium defined on the GN command. Hence if the primary ground is perfectly conducting (GN 1) and the GD command specifies a real ground with CLT=0, the currents will be computed for the structure over an infinite, perfectly conducting ground, and the radiated field will be computed for the ground parameters on the GD command.
- If a linear boundary is needed, the parameters on the GD command can be entered on the GN command. However, each solution with a new GN command requires recalculation of the matrix, while changing the parameters on GD does not.

GN – Ground Parameters

Purpose: To specify the relative dielectric constant and conductivity of the ground in the vicinity of the antenna. In addition, a second set of ground parameters for a second medium can be specified, or a radial-wire ground screen can be modeled using a reflection coefficient approximation.

Command:

```
GN  IPERF  NRADL  0  0  EPSR  SIG  F3  F4  F5  F6  [File Name]
      I1      I2      I3  I4   F1   F2   F3  F4  F5  F6
```

Note: The integer parameters I3 and I4 are not used. Zeros should be entered in these positions.

Parameters:

IPERF (I1) – Ground-type flag. The options are:

- 1 – nullifies ground parameters previously entered and sets free-space conditions. The remaining parameters are omitted in this case.
- 0 – finitely conducting ground, reflection-coefficient approximation.
- 1 – perfectly conducting ground.
- 2 – finitely conducting ground, Sommerfeld/Asymptotic method.

NRADL (I2) – Number of radial wires in the ground-screen approximation. If there is no ground screen, 0 must be entered for NRADL.

EPSR (F1) – Relative dielectric constant for ground in the vicinity of the antenna.

SIG (F2) – Conductivity in S/m of the ground. If SIG is input as a negative number, the complex dielectric constant $\tilde{\epsilon}_g = \epsilon_r - j\sigma/\omega\epsilon_0$ is set to $\text{EPSR} - j|\text{SIG}|$.

The remaining parameters are used to enter data for a second medium or a radial-wire ground screen. When both of these functions are needed the GD command must be used for the second-medium parameters. Options for the parameters are:

- a. – For an infinite ground plane F3 through F6 omitted.
- b. – For the radial-wire ground-screen approximation ($\text{NRADL} \neq 0$) the dimensions for the screen are entered as parameters F3 and F4. The screen is centered at the origin of the NEC coordinate system.
 - F3** – The radius of the screen in meters.
 - F4** – Radius of the screen wires in meters.

- c. – Second-medium parameters (NRADL = 0) for the medium beyond the primary ground plane (cliff problem.) These parameters alter the far field patterns but do not affect the antenna impedance or current distribution.
 - F3** – Relative dielectric constant of medium 2.
 - F4** – Conductivity of medium 2 in S/m.
 - F5** – Distance along the x axis to the linear boundary (parallel to the y axis) between the first and second media. For a circular boundary the GD command must be used.
 - F6** – Distance in meters (positive or zero) by which the surface of medium 2 is below medium 1.

Additional Information:

- With IPERF = 0, the reflection-coefficient approximation (RCA) offers a fast, approximate solution for structures over ground. Its use should be limited to structures at least several tenths of a wavelength above the ground surface, and it cannot be used to model long-wire antennas over ground. Since surface wave is not included in this approximation, the field will go to zero as the path between source and evaluation points approaches grazing incidence to the ground. The time to fill the interaction matrix with the RCA is about twice that for free space, due to computation of the field of the image of each source.
- When the Sommerfeld/Asymptotic ground model is used (IPERF = 2), NEC requires a table of Sommerfeld-integral values for the fields due to a source near ground. The Sommerfeld-integral table is independent of the structure being modeled and depends only on the complex relative permittivity of the ground $\tilde{\epsilon}_g = \epsilon_r - j\sigma/(2\pi f\epsilon_0)$ where f is the frequency. Hence it is independent of scaling and depends only on ϵ_r and the ratio σ/f . Since generating the values for the tables requires a moderate amount of computer time (about 73 seconds on a VAX 6350 computer) it is advantageous to save the table on a file if other problems with the same ground parameters and frequency will be run. The Sommerfeld-integral file for given ground parameters and frequency may be generated in advance of the NEC run by running the program SOMNTX, or it will be generated by NEC-4 before continuing with the moment-method solution. When NEC is run, a name for the Sommerfeld-integral file can be entered after the data on the GN command, with the file name separated from the data by a space or comma. Data from F3 on can be omitted if not used. If a file name is not given on the GN command, NEC looks for the default file name SOMS.NEC for single precision or SOMD.NEC for double precision. The file is binary, so a single precision NEC can only read a single precision file and a double precision NEC can only read a double precision file.
- If a file with the name specified on the GN command with IPERF=2 is not found,

or if the file is found but has the wrong ground parameters, NEC-4 will compute the Sommerfeld-integral table for use in the solution. It will also write the table on a file for later use, using the specified file name or the default name SOMS.NEC. If NOFILE is entered in place of the file name on the GN command, the file of Sommerfeld-integral values will not be written.

- If a data set requests the solution at multiple frequencies using the Sommerfeld ground model, NEC-4 will generate the Sommerfeld-integral tables for each frequency as needed. The tables will also be written to a sequence of files named SOMS.NEC, SOMS1.NEC, SOMS2.NEC, . . . or with the same pattern using a file name entered on the GN command. NEC also attempts to read files using this same naming sequence, so once a frequency loop has been completed, a subsequent data set or later NEC run using the same ground parameters and frequencies can read the files rather than recomputing the Sommerfeld-integral tables. If a data set repeats the solution for a sequence of different ground parameters, using multiple GN commands, a similar sequence of Sommerfeld-integral files can also be generated for later use. However, it is necessary to omit the file name from the GN commands and allow the default name to be used. Whenever a file name is included on the GN command that exact name will be used.
- With the Sommerfeld/Asymptotic solution the time to fill the interaction matrix will be about 6 to 8 times that for free space.
- The radial-wire ground screen approximation can be used only with the RCA (IPERF = 0) since it is based on a modified reflection coefficient. The reflection coefficient at each point on the ground is computed from the surface impedance, which is the parallel combination of the radial wire screen and the ground impedance. The radial-wire ground-screen approximation neglects important effects seen with a real ground screen, but may be useful with some antennas over a radial-wire screen. The impedance of the screen is zero at the center ($x = y = 0$) so the solution for a vertical monopole at this point will be the same as for the monopole on a perfectly conducting ground.
- The parameters for a second ground medium can be entered on the GN command as a convenience, but the usual command for defining these parameters is GD. The second medium affects the calculation of radiated field (RP command) but not antenna currents or near fields. However, if the second-medium parameters are modified by entering a new GN command the code will have to recompute the interaction matrix, since it will be assumed that the primary ground parameters may have been changed. More information on the use of a second ground medium can be found under the GD command.

IS – Insulated Wire

Purpose: To specify an insulating sheath of dielectric or lossy material on a wire.

Command:

IS	I1	ITAG	ITAGF	ITAGT	EPSR	SIG	RADI
	I1	I2	I3	I4	F1	F2	F3

Parameters:

- I1** – -1 to cancel previous sheath data, =0 otherwise for new data.
- ITAG (I2)** – Tag number; identifies the wire or wires to which the sheath will be applied. The next two parameters can be used to further define the choice. Zero here implies that absolute segment numbers are being used as the next two parameters to identify segments. If the next two parameters are zero, all segments with tag ITAG are insulated.
- ITAGF (I3)** – First segment among those segments having tag ITAG to which the sheath is to be applied. If ITAG is zero, ITAGF is an absolute segment number. If both ITAG and ITAGF are zero, all segments will be insulated.
- ITAGT (I4)** – Last segment among those segments having tag ITAG to which the sheath is to be applied. This parameter must be greater than or equal to the previous parameter. The sheath specified is applied to segments numbered ITAGF through ITAGT, counting only segment with tag ITAG. Again, if ITAG is zero, these parameters refer to absolute segment numbers. If ITAGT is zero, it is set equal to the previous parameter (ITAGF).
- EPSR (F1)** – relative permittivity of the sheath material.
- SIG (F2)** – conductivity of the sheath material (S/m).
- RADI (F3)** – radius of the sheath (m). RADI must be greater than the wire radius.

Additional Information:

- If several IS commands are grouped together their effects are combined. However, only a single sheath can be specified on a given segment. The maximum number of IS commands in a group is determined by dimensions in the program.
- Segment lengths on insulated wires should be chosen relative to the effective electrical length of the wire, following the rules in section 2.1. The program can be run first without computing a solution, but with a PS command to print the effective electrical lengths. Other guidelines for modeling insulated wires are given in section 2.7.

JN – Junction Charge Distribution

Purpose: To select the method of determining the distribution of charge in the basis functions.

Command:

JN I1

Parameters:

I1 – 0 or blank to switch from the moment-method solution for charge at a junction to the condition based on $\log(ka)$; I1= -1 to cancel a previous JN command and return to the moment-method solution for charge.

Additional Information:

- Normally the distribution of charge on wires at a junction is determined from a moment-method solution for continuity of potential at the junction. The resulting distribution of charge on the wires is then built into the current basis functions. The JN command can be used to switch to the charge condition used in NEC-2 and NEC-3 in which the charge on a wire with radius a_j is made proportional to $[\ln(2/ka_j) - \gamma]^{-1}$. This condition does not take account of the proximity of wires at the junction. The moment-method solution for charge, which is the default in NEC-4, should give the more accurate result, but the JN command can be used to compare the effect of the alternate junction treatment.

LD – Impedance Loading

Purpose: To specify the impedance loading on one segment or a number of segments. Series and parallel RLC circuits can be generated. In addition, a finite conductivity and permeability can be specified for segments.

Command:

LD	LDTYP	LDTAG	LDTAGF	LDTAGT	ZLR	ZLI	ZLC
	I1	I2	I3	I4	F1	F2	F3

Parameters:

- LDTYP (I1)** – Determines the type of loading which is used. The options are:
- 1 – short all loads (used to nullify previous loads.)
 - 0 – series RLC; input in ohms, henries, farads.
 - 1 – parallel RLC; input in ohms, henries, farads.
 - 2 – series RLC; input in ohms/meter, henries/meter, farads/meter.
 - 3 – parallel RLC; input ohms/meter, henries/meter, farads/meter.
 - 4 – impedance; input resistance and reactance in ohms.
 - 5 – wire conductivity, mhos/meter.
- LDTAG (I2)** – Tag number; identifies the wire sections to be loaded by their tag numbers. The next two parameters can be used to further specify particular segments with this tag number. Zero here implies that absolute segment numbers are being used as the next two parameters to identify segments. If the next two parameters are zero, all segments with tag LDTAG are loaded.
- LDTAGF (I3)** – First segment among those segments having tag LDTAG to which the loading is to be applied. If LDTAG is zero, LDTAGF then specifies an absolute segment number. If both LDTAG and LDTAGF are zero, all segments will be loaded.
- LDTAGT (I4)** – Last segment among those segments having tag LDTAG to which the loading is to be applied. This parameter must be greater than or equal to the previous parameter. The loading specified is applied to segments numbered LDTAGF through LDTAGT, counting only segment with tag LDTAG. Again, if LDTAG is zero, these parameters refer to absolute segment numbers. If LDTAGT is zero, it is set equal to LDTAGF.

Floating Point Input for the Various Load Types:

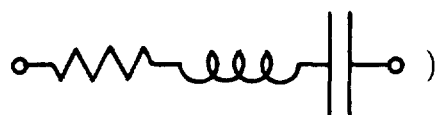
LDTYP=0 – Series RLC ()

ZLR (F1) – Resistance in ohms.

ZLI (F2) – Inductance in henries.

ZLC (F3) – Capacitance in farads; if none, enter zero.

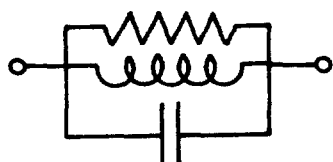
LDTYP=1 – Parallel RLC (), floating point input the same as

series. If the inductor is absent enter zero for ZLI.

LDTYP=2 – Series RLC with parameters per unit length.

ZLR (F1) – Resistance in ohms/m.

ZLI (F2) – Inductance in henries/m.

ZLC (F3) – Capacitance in farads/m; if none, enter zero.

LDTYP=3 – Parallel RLC, with parameters per unit length.

ZLR (F1) – Resistance in ohms/m.

ZLI (F2) – Inductance in henries/m; if none, enter zero.

ZLC (F3) – Capacitance in farads/m.

LDTYP=4 – Fixed impedance.

ZLR (F1) – Resistance in ohms.

ZLI (F2) – Reactance in ohms.

LDTYP=5 – Internal impedance is computed for a finitely conducting round wire.

ZLR (F1) – Bulk conductivity of metal in mhos/m.

ZLI (F2) – Relative permeability of the metal. If $\mu_r = 1$, ZLI can be omitted.

Additional Information:

- Loading commands can be input in groups to achieve a desired structure loading. The maximum number of loading commands in a group is determined by dimensions in the program. The limit is presently 30.

LD

- If a segment is loaded more than once by a group of loading commands, the loads are assumed to be in series (impedances added), and a message is printed in the output alerting the user to this fact.
- When resistance and reactance are input ($LDTYP = 4$), the impedance does not automatically scale with frequency.
- Since loading modifies the interaction matrix, it will affect the conditions of plane or cylindrical symmetry of a structure. If a structure is geometrically symmetric and each symmetric section is to receive identical loading, then symmetry may be used in the solution. The program is set to utilize symmetry during geometry input by inputting the data for one symmetric section and completing the structure with a GR or GX command. If symmetry is used, the loading on only the first symmetric section is input on LD commands. The same loading will be assumed on the other sections. Loading should not be specified for segments beyond the first section when symmetry is used. If the sections are not identically loaded, then during geometry input the program must be set to a no-symmetry condition to permit independent loading of segments in different sections. The way to do this is described under the GW command.

LE – Near Electric Field Along a Line

Purpose: To compute the near electric field along a line in space and also evaluate the line integral of E .

Command:

LE	RSET	NPTS	0	0	X1	Y1	Z1	X2	Y2	Z2
	I1	I2	I3	I4	F1	F2	F3	F4	F5	F6

Note: The integer parameters I3 and I4 are not used. Zeros should be entered in these positions.

Parameters:

- RSET (I1)** – -1 to reset the cumulative line integral value to zero; otherwise equal to 0.
- NPTS (I2)** – number of points from (X1, Y1, Z1) to (X2, Y2, Z2).
- X1 (F1)** – Initial x coordinate in meters.
- Y1 (F2)** – Initial y coordinate in meters.
- Z1 (F3)** – Initial z coordinate in meters.
- X2 (F4)** – Final x coordinate in meters.
- Y2 (F5)** – Final y coordinate in meters.
- Z2 (F6)** – Final z coordinate in meters.

Additional Information:

- The near electric field is computed at NPTS equally spaced points along the line from (X1, Y1, Z1) to (X2, Y2, Z2). The field component along the axial unit vector \hat{a} in the direction of this line is printed. Also components along the horizontal vector $\hat{h} = \hat{z} \times \hat{a} / |\hat{z} \times \hat{a}|$ and the vector in the vertical plane $\hat{v} = \hat{a} \times \hat{h}$ are printed.
- Following the table of field values, the line integral of the electric field ($E \cdot \hat{a}$) from (X1, Y1, Z1) to (X2, Y2, Z2) is printed. The integral is evaluated using the trapezoidal rule at the NPTS points. If several LE commands are read in succession the cumulative line integral will be printed. Thus if the lines specified by successive LE commands start where the previous line ended the code will evaluate the line integral along the piecewise-linear path which may close on itself. LH commands may be mixed with LE commands, and the code will retain the cumulative line integrals of E and H until a different command breaks the sequence or until a command with RSET=-1 is read to reset the cumulative values.

LH – Near Magnetic Field Along a Line

Purpose: To compute the near magnetic field along a line in space and also evaluate the line integral of H.

Command:

LH	RSET	NPTS	0	0	X1	Y1	Z1	X2	Y2	Z2
	I1	I2	I3	I4	F1	F2	F3	F4	F5	F6

Note: The integer parameters I3 and I4 are not used. Zeros should be entered in these positions.

Parameters:

- RSET (I1)** – -1 to reset the cumulative line integral value to zero; otherwise equal to 0.
NPTS (I2) – number of points from (X1, Y1, Z1) to (X2, Y2, Z2).
X1 (F1) – Initial x coordinate in meters.
Y1 (F2) – Initial y coordinate in meters.
Z1 (F3) – Initial z coordinate in meters.
X2 (F4) – Final x coordinate in meters.
Y2 (F5) – Final y coordinate in meters.
Z2 (F6) – Final z coordinate in meters.

Additional Information:

- The near magnetic field is computed at NPTS equally spaced points along the line from (X1, Y1, Z1) to (X2, Y2, Z2). The field component along the axial unit vector \hat{a} in the direction of this line is printed. Also components along the horizontal vector $\hat{h} = \hat{z} \times \hat{a} / |\hat{z} \times \hat{a}|$ and the vector in the vertical plane $\hat{v} = \hat{a} \times \hat{h}$ are printed.
- Following the table of field values, the line integral of the magnetic field ($\mathbf{H} \cdot \hat{a}$) from (X1, Y1, Z1) to (X2, Y2, Z2) is printed. The trapezoidal rule is used in evaluating the integral. If several LH commands are read in succession the cumulative line integral will be printed. Thus if the lines specified by successive LH commands start where the previous line ended the code will evaluate the line integral along the piecewise-linear path which may close on itself. LE commands may be mixed with LH commands, and the code will retain the cumulative line integrals of E and H until a different command breaks the sequence or until a command with RSET=-1 is read to reset the cumulative values.

NE – Near Electric Field

Purpose: To request calculation of near electric fields in the vicinity of the antenna.

Command:

NE	NEAR	NRX	NRY	NRZ	XNR	YNR	ZNR
	I1	I2	I3	I4	F1	F2	F3
		DXNR	DYNR	DZNR			
		F4	F5	F6			

Parameters:

NEAR (I1) – Selects the type of coordinate system for locating the evaluation points.

The options are:

- 0 – rectangular coordinates.
- 1 – spherical coordinates.

For either choice the field components will be printed in rectangular coordinates. The functions of the remaining parameters depend on the value of NEAR.

NEAR=0 – Evaluation points are specified in rectangular coordinates (x, y, z). The x coordinate is incremented the most rapidly (in the inner loop), followed by the y coordinate and then z .

NRX (I2) – Number of points in the x direction.

NRY (I3) – Number of points in the y direction.

NRZ (I4) – Number of points in the z direction.

XNR (F1) – Initial x coordinate in meters.

YNR (F2) – Initial y coordinate in meters.

ZNR (F3) – Initial z coordinate in meters.

DXNR (F4) – increment for x (meters).

DYNR (F5) – increment for y (meters).

DZNR (F6) – increment for z (meters).

NEAR=1 – Evaluation points are specified in spherical coordinates (r, θ, ϕ). The r coordinate is incremented the most rapidly (in the inner loop), followed by the θ coordinate and then ϕ .

NRX (I2) – Number of points in the r direction.

NRX (I3) – Number of points in the θ direction.

NRZ (I4) – Number of points in the ϕ direction.

XNR (F1) – Initial r coordinate in meters.

YNR (F2) – Initial θ coordinate in degrees.

ZNR (F3) – Initial ϕ coordinate in degrees.

DXNR (F4) – increment for r (meters).

DYNR (F5) – increment for θ (degrees).

DZNR (F6) – increment for ϕ (degrees).

Additional Information:

- When only one frequency is being used, near-field commands may be grouped together in order to calculate fields at points with various coordinate increments. In this case, each command encountered produces an immediate execution of the MoM solution, and the results are printed. When automatic frequency stepping is being used (NFRQ on the FR command is greater than one), only one NE or NH command can be used for program control inside the frequency loop. Furthermore, the NE or NH command does not initiate an execution in this case. Execution will begin only after a subsequent radiation-pattern command (RP) or execution command (XQ) is read.
- The time required to calculate the field at one point is equivalent to filling one row of the matrix. Thus, if there are N segments in the structure, the time required to calculate fields at N points is equal to the time required to fill the $N \times N$ interaction matrix.
- When a ground is present, the near electric field is computed using the form of field evaluation that was selected on the GN command. If the reflection-coefficient approximation is used to evaluate the field at a distant point on the ground, the field strength may be greatly underestimated since the surface wave is not included.

NH – Near Magnetic Field

Purpose: To request calculation of near magnetic fields in the vicinity of the antenna.

Command:

NH	NEAR	NRX	NRY	NRZ	XNR	YNR	ZNR
	I1	I2	I3	I4	F1	F2	F3
	DXNR	DYNR	DZNR				
	F4	F5	F6				

Parameters:

NEAR (I1) – Selects the type of coordinate system for locating the evaluation points.

The options are:

0 – rectangular coordinates.

1 – spherical coordinates.

For either choice the field components will be printed in rectangular coordinates. The functions of the remaining parameters depend on the value of NEAR.

NEAR=0 – Evaluation points are specified in rectangular coordinates (x, y, z). The x coordinate is incremented the most rapidly (in the inner loop), followed by the y coordinate and then z .

NRX (I2) – Number of points in the x direction.

NRY (I3) – Number of points in the y direction.

NRZ (I4) – Number of points in the z direction.

XNR (F1) – Initial x coordinate in meters.

YNR (F2) – Initial y coordinate in meters.

ZNR (F3) – Initial z coordinate in meters.

DXNR (F4) – Increment for x (meters).

DYNR (F5) – Increment for y (meters).

DZNR (F6) – Increment for z (meters).

NEAR=1 – Evaluation points are specified in spherical coordinates (r, θ, ϕ). The r coordinate is incremented the most rapidly (in the inner loop), followed by the θ coordinate and then ϕ .

NRX (I2) – Number of points in the r direction.

NRX (I3) – Number of points in the θ direction.

NRZ (I4) – Number of points in the ϕ direction.

XNR (F1) – Initial r coordinate in meters.

YNR (F2) – Initial θ coordinate in degrees.

ZNR (F3) – Initial ϕ coordinate in degrees.

DXNR (F4) – Increment for r (meters).

DYNR (F5) – Increment for θ (degrees).

DZNR (F6) – Increment for ϕ (degrees).

Additional Information:

- When only one frequency is being used, near-field commands may be grouped together in order to calculate fields at points with various coordinate increments. In this case, each command encountered produces an immediate execution of the MoM solution, and the results are printed. When automatic frequency stepping is being used (NFRQ on the FR command is greater than one), only one NE or NH command can be used for program control inside the frequency loop. Furthermore, the NE or NH command does not initiate an execution in this case. Execution will begin only after a subsequent radiation-pattern command (RP) or execution command (XQ) is read.
- When a ground plane is modeled with the Sommerfeld/Asymptotic solution, the near magnetic field will be computed from a finite-difference evaluation of $\nabla \times \mathbf{E}$ using central differences. Hence the time required for each magnetic field evaluation will be six times the time for a single electric field evaluation. Also, the evaluation of differences may magnify errors due to the table-lookup for the electric field or due to transitions from table lookup to asymptotic approximations. These errors are most noticeable at very low frequencies. The increment used for the differences is $\pm 0.001\lambda$ in x, y and z . Hence the evaluation point should not be closer than 0.001λ to any boundary, such as the ground surface.
- When the reflection coefficient approximation (RCA) has been selected on the GN command, the near magnetic field is computed directly using the reflection coefficient. However, the field at a distant point on the ground may be greatly under estimated with the RCA, since the surface wave is not included.

NT – Non-Radiating Networks

Purpose: To specify a two-port non-radiating network connected between any two segments in the structure. The characteristics of the network are specified by its short-circuit admittance-matrix parameters.

Command:

NT	TAG1	SEG1	TAG2	SEG2	Y11R	Y11I	Y12R	Y12I
	I1	I2	I3	I4	F1	F2	F3	F4
		Y22R	Y22I					
		F5	F6					

Parameters:

- TAG1 (I1)** – Tag number for the segment to which port one of the network connects
- SEG1 (I2)** – Segment number defining the segment to which port one of the network connects. The segment can be specified by the tag number (TAG1) and segment number (SEG1) within the set of segments having tag TAG1. Otherwise, if TAG1 is zero then SEG1 refers to absolute segment number. A value of -1 for SEG1 will cancel any networks or transmission lines that have been defined previously.
- TAG2 (I3)** – Tag number for the segment to which port two of the network connects
- SEG2 (I4)** – Segment number defining the segment to which port two of the network connects.

The six floating-point parameters specify the real and imaginary parts of the three short-circuit admittance-matrix elements Y_{11} , Y_{12} and Y_{22} . The admittance matrix is symmetric so it is unnecessary to specify Y_{21} . The sign of Y_{12} must be determined for the reference directions for current into the positive side of each port.

- Y11R (F1)** – Real part of Y_{11} in mhos.
- Y11I (F2)** – Imaginary part of Y_{11} in mhos.
- Y12R (F3)** – Real part of Y_{12} in mhos.
- Y12I (F4)** – Imaginary part of Y_{12} in mhos.
- Y22R (F5)** – Real part of Y_{22} in mhos.
- Y22I (F6)** – Imaginary part of Y_{22} in mhos.

Additional Information:

- Several NT commands may be combined to specify networks on a structure. NT and TL commands may be intermixed in a group, but all must occur together, with no other

commands separating them. When the first NT or TL command is read following a command other than NT or TL, all previous network and transmission line data are destroyed. Hence, if a set of network data is to be modified, all network data must be entered again in the modified form. Dimensions in the program limit the number of networks that can be specified. The maximum number of networks and transmission lines that may be specified is set by the parameter MAXNET.

- One or more network ports can connect to any given segment. Multiple network ports connected to a segment are connected in parallel.
- If a network is connected to a segment which also has an impedance load (LD command) the load is on the wire in series with the network port.
- A voltage source specified on the same segment as a network port is connected in parallel with the network port, and in series with any load specified by an LD command.
- NT commands can be used as an alternative to LD to specify impedance loading on segments. While only fixed admittances can be specified in this way, the technique has the advantage that loads placed with a NT command do not change the structure interaction matrix. Hence if unsymmetric loads are specified with NT commands, the code can still take advantage of structure symmetry in the solution procedure. Also, each time that loads entered with NT commands are changed the code only needs to solve for the new currents. The interaction matrix does not need to be recomputed and factored, as would be done if loads defined with the LD command were changed.
- When defining network admittance parameters, it must be remembered that the reference direction for current is into the positive side of each port. Some examples of two-port networks, and the corresponding admittance parameters follow:

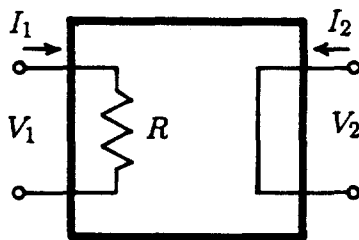

$$Y_{11} = 1/R \quad Y_{22} = 10^{10}$$

$$Y_{12} = 0$$

Fig. 11 Shunt resistance.

Port one of the network in figure 11 can be connected to a segment to introduce a load of R ohms. Port two can be connected to any other segment with no effect.

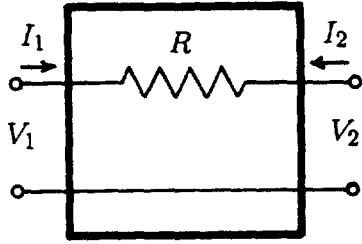

$$Y_{11} = Y_{22} = 1/R$$

$$Y_{12} = -1/R$$

Fig. 12 Series resistance.

Note that the network in figure 12 is not the same as connecting a single wire with a resistance between two points on the structure. The net current transferred between ports one and two by the network is zero, since the currents are balanced at each port.

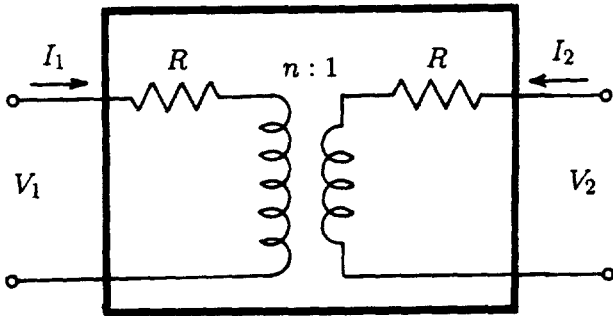

$$Y_{11} = \frac{1}{R(1+n^2)}$$

$$Y_{22} = \frac{n^2}{R(1+n^2)}$$

$$Y_{12} = \frac{-n}{R(1+n^2)}$$

$$R \neq 0$$

Fig. 13 A transformer with loss.

An ideal transformer with zero loss cannot be defined since the short-circuit admittance parameters for it cannot be written. If a low-loss transformer is needed, R in the network of figure 13 can be reduced until the solution starts to become unstable. The minimum R will depend on the precision of the computer.

NX – Next Structure

Purpose: To mark the end of data for one data set and the beginning of data for the next structure in the input file.

Command:

NX

Parameters: none

Note: The command that directly follows the NX command must be a CM, CE or structure-geometry data for the next antenna.

PQ – Printing Options for Charge on Wires

Purpose: To control the printing of charge densities on wire segments.

Command:

PQ	IPTFLQ	IPTAQ	IPTAQF	IPTAQT
	I1	I2	I3	I4

Parameters:

- IPTFLQ (I1)** – Print control flag:
- 1 – Suppress printing of charge densities. This is the default condition.
 - 0 – Print charge densities on segments specified by the following parameters. If the following parameters are zero or blank, charge densities will be printed for all segments.
- IPTAQ (I2)** – Tag number of the segments for which charge densities will be printed.
- IPTAQF (I3)** – First segment for which charge densities will be printed, counting only segments with tag IPTAQ. If IPTAQ is zero then IPTAQF refers to an absolute segment number. If IPTAQF is zero the charge is printed for all segments.
- IPTAQT (I4)** – Last segment for which charge densities will be printed, counting only segments with tag IPTAQ. Charge densities are printed for segments having tag number IPTAQ starting at segment IPTAQF in the set and ending at segment IPTAQT. If IPTAQ is zero IPTAQF and IPTAQT refer to absolute segment numbers. If IPTAQT is zero it is set equal to IPTAQF

PS – Print Electrical Lengths of Segments

Purpose: To print a table of segment coordinates, length and radius relative to the effective wavelength for current propagating on the wire.

Command:

PS

Parameters: None

Additional Information:

- PS prints the segment lengths and radii relative to the effective wavelength λ_s for current propagating on the wire. For ordinary wires in free space or in any medium, λ_s is the wavelength in the medium. For an insulated wire in a dielectric or conducting medium, λ_s is computed as $\lambda_s = 2\pi/k_s$ where k_s is the wavenumber for current propagating on the wire, determined by the transmission-line approximation for an insulated wire from [14]. The length λ_s should be used in determining the segment lengths and radii by the rules in section 2.1.
- If PS is followed by EN, the table of electrical lengths can be obtained without executing the solution. Segment lengths can then be adjusted before solving for currents.

PT – Printing Options for Currents on Wires

Purpose: To control the printing of currents on wire segments. Current printing can be suppressed, limited to a few segments, or special formats for receiving patterns can be requested.

Command:

PT	PTFLG	PTAG	PTAGF	PTAGT
	I1	I2	I3	I4

Parameters:

- PTFLG (I1)** – Print control flag, specifies the type of format used in printing segment currents. The options are:
- 2 – All currents are printed. This is a default value for the program if the command is omitted.
 - 1 – Suppress printing of all wire-segment currents.
 - 0 – Current printing will be limited to the segments specified by the next three parameters.
 - 1 – Currents are printed in a format designed for a receiving pattern. An example is shown in Example 3 in sample output in Section 4. Only currents for the segments specified by I2, I3 and I4 are printed.
 - 2 – Same as for 1 above. However, in addition the current for one segment will be normalized to its maximum, and the normalized values along with the relative strength in dB will be printed in a table. If the currents for more than one segment are being printed, only currents from the last segment in the group appear in the normalized table.
 - 3 – Only normalized currents from one segment are printed for the receiving pattern case.
- PTAG (I2)** – Tag number of the segments for which currents will be printed.
- PTAGF (I3)** – First segment for which currents will be printed, counting only segments with tag PTAG. If PTAG is zero then PTAGF refers to an absolute segment number. If PTAGF is zero the current is printed for all segments.
- PTAGT (I4)** – Last segment for which currents will be printed, counting only segments with tag PTAG. Currents are printed for segments having tag number PTAG starting at segment PTAGF in the set and ending at segment PTAGT. If PTAG is zero PTAGF and PTAGT refer to absolute segment numbers. If PTAGT is zero it is set equal to PTAGF

RP – Radiation Pattern

Purpose: To request the calculation of radiation patterns, ground wave and average gain.

Command:

RP	I1	NTH	NPH	XNDA	THETS	PHIS	DTH	DPH
	I1	I2	I3	I4	F1	F2	F3	F4
		RFLD	GNOR					
		F5	F6					

Parameters:

- I1** – selects the mode of the calculation for the radiated field. The value of I1 affects the meaning of the remaining parameters in the command. The options are:
- 0 – The space-wave field is computed in spherical coordinates.
 - 1 – The total ground wave is computed, including surface wave, in a cylindrical coordinate system.
- NTH (I2)** – Number of values of θ at which the field is to be computed (number of values of z for I1=1).
- NPH (I3)** – Number of values of ϕ at which the field is to be computed. The total number of field points requested by the command is NTH×NPH. If I2 or I3 is zero, a value of one will be assumed.
- XNDA (I4)** – This optional integer consists of four independent digits, each having a different function. The mnemonic XNDA is not a variable name in the program. Rather, each letter, X-N-D-A, represents a mnemonic for the corresponding digit in I4. If I1=1, then the options selected by I4 cannot be used. A value of zero can then be entered for XNDA. The options are:
- X** – controls output format for antenna gain. If X=0, then major-axis, minor-axis and total gain are printed. If X=1, then vertical, horizontal and total gain are printed.

- **N** - causes normalized gain for the specified field points to be printed after the standard gain and field-strength output. The number of field points for which the normalized gain can be printed is limited by an array dimension which is 4 times the parameter MAXSEG. If the number of field points exceeds this limit, the remaining points will be omitted from the table of normalized gains. The gain will be normalized to the value entered for GNOR, or to the maximum gain if GNOR is zero. The component of gain that is normalized is determined by the value of N as follows:
 - N = 0 for no normalized gain.
 - = 1 major axis gain normalized.
 - = 2 minor axis gain normalized.
 - = 3 vertical axis gain normalized.
 - = 4 horizontal axis gain normalized.
 - = 5 total gain normalized.

- D** - selects either power gain (D=0) or directive gain (D=1) for both the gain-field value tables and for normalization. If the structure excitation is an incident plane wave, the quantities printed under the heading "GAIN" will actually be the scattering cross section (σ/λ^2) and will not be affected by the value of D. The column heading for the output will still read "POWER GAIN" or "DIRECTIVE GAIN," however.

- A** - requests calculation of average power gain over the sector of space within the limits selected for θ and ϕ .
 - A = 0 no average gain calculation.
 - A = 1 average gain is computed.
 - A = 2 average gain is computed but printing of the individual gain and field values is suppressed.

- THETS (F1)** - initial θ angle in degrees (initial z coordinate in meters if I1=1).
- PHIS (F2)** - initial ϕ angle in degrees.
- DTH (F3)** - increment for θ in degrees (increment for z in meters if I1=1).
- DPH (F4)** - Increment for ϕ in degrees.
- RFLD (F5)** - Radial distance (R) in meters of the field point from the origin. RFLD is optional. If zero (or blank if F6 is not used), the radiated field will have the factor $\exp(-jkR)/R$ omitted. If a value of R is specified, it should represent a point in the far-field region since near components of the field cannot be obtained with an RP command. If I1=1, then RFLD represents the cylindrical coordinate ρ in meters and is not optional. A non-zero value of RFLD must be entered, and the value should be greater than about a wavelength so that the asymptotic approximations for field over ground will be accurate.

GNOR (F6) – The gain normalization factor if normalization has been requested in the I4 parameter. If GNOR is blank or zero, the gain will be normalized to its maximum value. If GNOR is not zero, the gain will be normalized to the value of GNOR.

Additional Information:

- The RP command will initiate program execution, causing the interaction matrix to be computed and factored and the structure currents to be computed if these operations have not already been performed. Hence, all required input parameters must be set before the RP command is read.
- At a single frequency, any number of RP commands may occur in sequence so that different field-point spacings may be used over different regions of space. If automatic frequency stepping is used (i.e., NFRQ on the FR command is greater than one), only one RP command will act within the frequency loop. Subsequent RP commands will calculate patterns at the final frequency only.
- When both NTH and NPH are greater than one, the angle θ (or z when I1=1) will be stepped faster than ϕ .
- The code computes average gain by integrating the radiated power over a sector of space determined by the range of θ and ϕ . The power integrated in this sector is then divided by the solid angle of the sector and multiplied by 4π . The result is the total power that would be radiated by the antenna if radiation into other sectors of space duplicated that in the integrated sector. This procedure is used to reduce the number of radiated-field evaluations needed when the user can see, due to symmetry, that the radiation pattern will repeat over symmetric sections. For example, for a vertical dipole or monopole, only two cuts in θ with different values for ϕ are needed. The result for power radiated into 4π steradians is printed by NEC-4, and can be obtained with earlier codes by multiplying the average gain by the input power from the "POWER BUDGET" table. If the antenna is over a ground plane with either finite or perfect conductivity, the radiation below the ground plane ($\theta > 90^\circ$) is zero. Hence the result obtained for radiated power into 4π steradians will be twice the actual power radiated, when the sector integrated is only in the upper half-space. The average gain computed for a lossless antenna should be 1.0 if the antenna is in free space and 2.0 over perfectly conducting ground with the integration in the upper half-space. Integrating the power in the far field gives the total radiated power in a variational form which is insensitive to small errors in the computed current distribution. Hence, the power obtained in this way should be more accurate than the input power computed at the source. The latter is sensitive to errors in the source voltage and current.

TL – Transmission Line

Purpose: To specify a transmission line between any two wire segments on a structure. Characteristic impedance, length and shunt admittance are the defining parameters.

Command:

TL	TAG1	SEG1	TAG2	SEG2	ZC	TLEN	Y1R	Y1I	Y2R	Y2I
I1	I2	I3	I4	F1	F2	F3	F4	F5	F6	

Parameters:

- TAG1 (I1)** – Tag number for the segment to which the first end of the transmission line connects.
- SEG1 (I2)** – Segment number to which the first end of the transmission line connects, counting only segments with tag TAG1. If TAG1 is zero then SEG1 refers to the absolute segment number. A value of –1 for SEG1 will cancel any networks or transmission lines that have been defined previously.
- TAG2 (I3)** – Tag number for the segment to which the second end of the transmission line connects
- SEG2 (I4)** – Segment number to which the second end of the transmission line connects, counting only segments with tag TAG2. If TAG2 is zero then SEG2 refers to the absolute segment number.
- ZC (F1)** – Characteristic impedance of the transmission line in ohms. A negative sign in front of ZC will act as a flag for generating a “crossed” transmission line with a 180° phase reversal relative to the reference directions of the segments. The characteristic impedance of the line will still be |ZC|.
- TLEN (F2)** – Length of the transmission line in meters. If TLEN is entered as zero, the program will use the straight-line distance between the specified connection points. If a zero-length transmission line is desired, a very small value, such as 1.E-10, should be entered for TLEN.
- Y1R (F3)** – Real part of the shunt admittance across end one of the transmission line (S).
- Y1I (F4)** – Imaginary part of the shunt admittance across end one of the transmission line (S).
- Y2R (F5)** – Real part of the shunt admittance across end two of the transmission line (S).
- Y2I (F6)** – Imaginary part of the shunt admittance across end two of the transmission line (S).

Additional Information:

- Several TL commands may be combined to specify transmission lines on a structure. NT and TL commands may be intermixed in a group, but all must occur together, with no other commands separating them. When the first NT or TL command is read following

a command other than NT or TL, all previous network and transmission line data are destroyed. Hence, if a set of transmission line data is to be modified, all transmission lines and networks must be entered again in the modified form. Dimensions in the program limit the number of TL commands that can be used. The maximum number of networks and transmission lines that can be specified is set by the parameter MAXNET.

- One or more transmission lines or network ports can connect to any given segment. Multiple transmission lines and network ports connected to a segment are connected in parallel.
- If a transmission line is connected to a segment which also has an impedance load (LD command) the load is on the wire in series with the transmission line connection(s).
- A voltage source specified on the same segment as a transmission line is connected in parallel with the transmission line, and in series with any load specified by an LD command. A shunt load specified on the TL command will be across the voltage source.
- NT and TL commands do not affect the interaction matrix or symmetry conditions in the solution.
- Sometimes it is necessary to have a transmission line with one end free from the structure but shorted, or to have several transmission lines connected in parallel at a point separate from the wire structure. Such configurations can be obtained with TL commands by including very short, isolated segments in the model as connection points for the ends of the transmission lines. Ordinarily single isolated segments should not be used, since the solution for current will not be accurate. However, if the segment length is on the order of 10^{-4} or less, the current on the segment will be negligible. The segments provide a means of equating the voltages and currents on the connected transmission lines or network ports.

UM – Upper Medium Parameters

Purpose: To specify the relative permittivity and conductivity of an infinite medium or of the upper medium over a ground plane.

Command:

UM	0	0	0	0	EPSR	SIG
	I1	I2	I3	I4	F1	F2

Note: The integer parameters I1 through I4 are not used. Zeros should be entered in these positions.

Parameters:

EPSR (F1) – Relative permittivity of the medium

SIG (F2) – Conductivity of the medium in S/m. If SIG is input as a negative number, the conductivity is set to $\omega\epsilon_0|\text{SIG}|$ so that the complex relative permittivity is $\tilde{\epsilon} = \epsilon_r - j\sigma/\omega\epsilon_0 = \text{EPSR} - j|\text{SIG}|$.

Additional Information:

- Parameters set by UM may affect the conditions for choosing segment lengths and patch sizes in the model. See section 2.6.
- UM cannot be used with the Sommerfeld/Asymptotic ground model (GN2, ...).

VC – Voltage-Source End Caps

Purpose: To include end caps on segments with voltage sources and loads.

Command:

VC I1

Parameters:

I1 – -1 to cancel a previous VC command.

Additional Information:

- End caps may be included on segments with voltage sources and impedance loads to reduce the excitation of the inside of the wire at these points. The end caps are most important when the segment length to radius ratio (Δ/a) is small. For Δ/a less than about 2, the charge distribution obtained without end caps may start to show an unnatural kink near the source. For a real source voltage, the imaginary part of current and real part of charge will start to oscillate as Δ/a is reduced further. Including end caps on voltage sources and loads should eliminate this oscillation. However, when a source is near to an end of the wire, the treatment of end caps may introduce a small error in the effective source voltage. Hence the voltage-source end caps have been made optional until their effect is better understood.

WG – Write NGF File

Purpose: To write a NGF file for a structure to save the solution for later use.

Command:

WG [File Name]

Parameters: none

Additional Information:

- A file name for the Numerical Green's Function file can be entered after WG, separated from the command code by a space or comma. If no file name is entered, the default file name of NGFS.NEC will be used.
- See section 3.6 for rules on writing and using Numerical Green's Function files.

XQ – Execute

Purpose: To request execution of the solution for current. Options also allow for computation of radiation patterns in either of two vertical cuts.

Command:

XQ I1

Parameters:

I1 – Options controlled by I1 are:

- 0 – no radiation patterns computed (normal case).
- 1 – computes radiation pattern in x - z plane ($\phi = 0^\circ$) with θ varying from 0° to 90° in 1° steps.
- 2 – computes radiation pattern in y - z plane ($\phi = 90^\circ$) with θ varying from 0° to 90° in 1° steps.
- 3 – computes radiation pattern in both $\phi = 0^\circ$ and $\phi = 90^\circ$ planes.

Additional Information:

- When a single frequency is requested (NFRQ=1 on the FR command) there are four commands that will initiate the solution procedure – XQ, RP, NE and NH. XQ does the minimum, computing and printing currents but not radiated fields unless the options available with I1 are used. When multiple frequencies are requested, only the XQ and RP commands will cause program execution. If a NE or NH command is read the program will remember that request, but will wait for a XQ or RP to begin the solution. If no command requesting execution is read, the program will read the data and stop without computing results.

3.4 Examples of Structure Geometry Data

The basic means for defining the structure geometry are the commands that generate segments (GW, CW, GA and GH) and patches (SP and SM.) In addition, there are several other commands that can be used to transform or duplicate segments and patches, so that a given structure can be defined in many different ways. The sequence of defining the model and the resulting ordering of segments and patches should have no effect on the results of the moment-method solution. However, when symmetries exist in the model, the method of entering the data can have a large effect on solution time. Some examples of input commands for defining wire and patch structures follow: These examples are intended only to illustrate points about entering structure data, and other commands are needed to set the frequency, excitation, etc. for a complete input file.

Rhombic Antenna — No Symmetry

The following set of input commands define the segment data for a rhombic antenna with 40 segments, as shown in figure 14:

```

GW 1 10 -350. 0. 150. 0. 150. 150. 0.1
GW 2 10 0. 150. 150. 350. 0. 150. 0.1
GW 3 10 -350. 0. 150. 0. -150. 150. 0.1
GW 4 10 0. -150. 150. 350. 0. 150. 0.1
GS 0 0 0.3048
GE
  
```

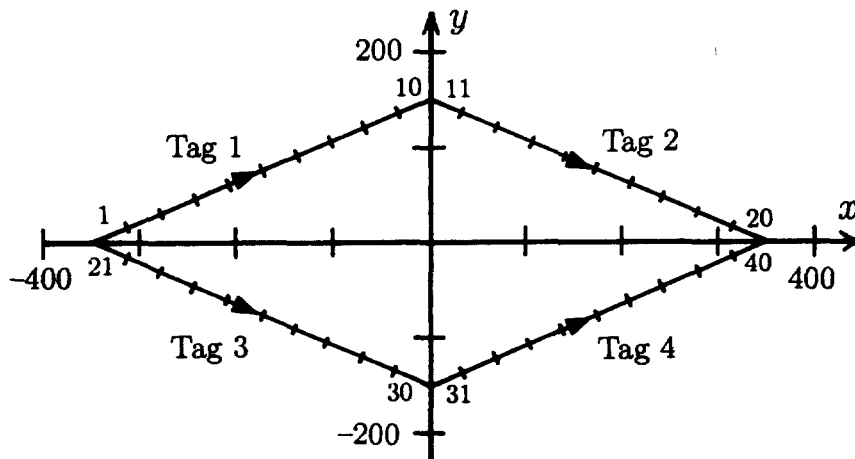

Fig. 14 Rhombic antenna — no symmetry.

The data are input in dimensions of feet and scaled to meters. In the figure, the numbers near the wires represent segment numbers and the reference directions for positive current, from the first to the second end of each wire entered, are shown by arrows. To place a voltage

source on the left-hand end of the rhombic, half of the voltage could be located on each of segments 1 and 21. However, due to the opposing reference directions of these segments, the voltage on segment 21 would have to be the negative of that on segment 1. Although the structure has two planes of symmetry, the solution cannot take advantage of symmetry because each wire has been entered with a separate GW command.

Rhombic Antenna — Two Planes of Symmetry

The following input data define the rhombic antenna using reflections to produce the structure as shown in figure 15:

```

GW 1 10 -350. 0. 150. 0. 150. 150. 0.1
GX 1 110
GS 0 0 0.3048
GE

```

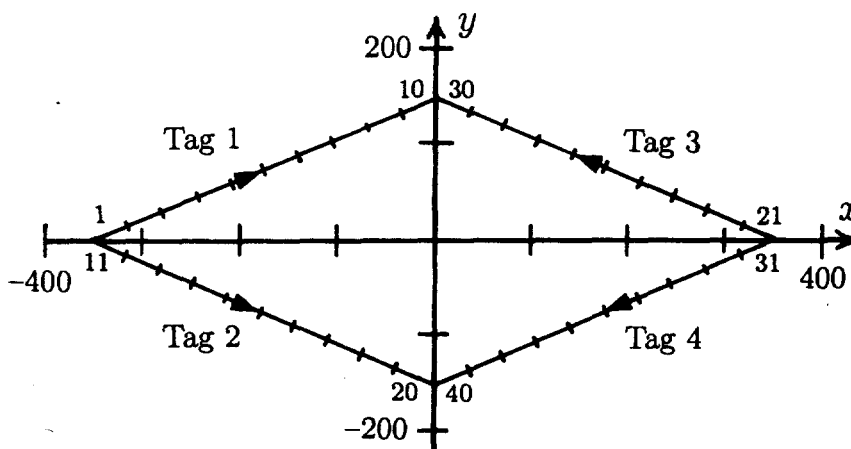

Fig. 15 Rhombic antenna — two planes of symmetry.

This structure is equivalent to that in figure 14, but only a single GW command is used. The GX command then reflects the wire, first along the y axis (about the x-z plane) and then along the x axis (about the y-z plane.) With this input the code will take full advantage of symmetry. Only 10 x 40 interaction elements are computed and stored, and the time to LU factor the matrix will be reduced by a factor of 16. The change in the segment ordering and reference directions must be taken into account in specifying sources and loads. Since each of the four wires is considered symmetric with the others, LD commands cannot be used to load segments 21 and 31, as might be needed for a terminating load if segments 1 and 11 are excited with voltage sources. If segment 1 is loaded with a LD command, segments 11, 21 and 31 will automatically receive the same load. A NT command can be used to load segments 21 and 31 without affecting the symmetry in the solution.

Rhombic Antenna — One Plane of Symmetry

The following data define the rhombic antenna with one plane of symmetry.

```
GW 1 10 -350. 0. 150. 0. 150. 150. 0.1
GX 1 100
GX 2 010
GS 0 0 0.3048
GE
```

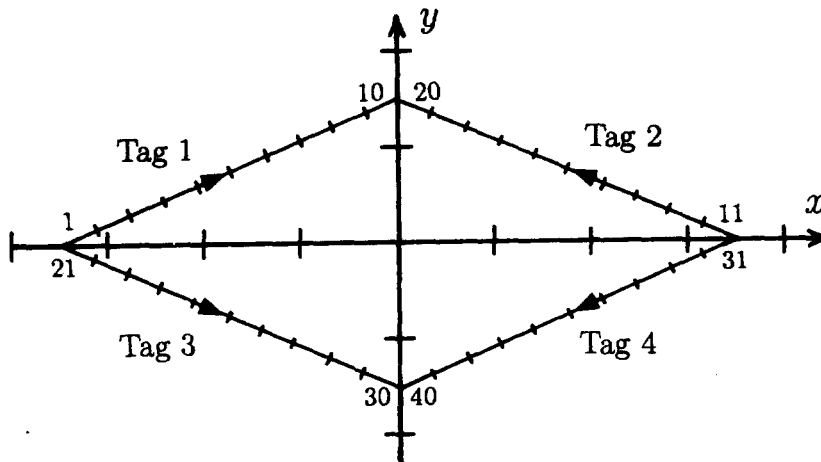

Fig. 16 Rhombic antenna — one plane of symmetry.

Segments 1 through 20 in figure 16 are in the first symmetric section, so segments 11 and 31 can be loaded with a LD command without affecting segments 1 and 21. Half of the terminating load impedance would be put on segment 11, and it would automatically be reflected onto segment 31. However, the code will have to compute and store a 20 by 40 interaction matrix.

Two Coaxial Loops

The two coaxial loops in figure 17 are formed by using a GR command to produce a structure with 8-fold rotational symmetry. The first 45 degree section of the two loops is generated by the first three commands. This section is then rotated about the z axis to complete the structure, and the loops are rotated and translated into the desired position relative to the origin using the GM command. Since no tag increment has been specified on the GR command, all segments on the outer loop will have tags of 1 and all segments on the inner loop will have tags of 2. Hence, all segments of the inner or outer loop can be loaded with a single LD command despite the staggered ordering of the segments. Because of symmetry, the solution will require computation and storage of only a 3 by 24 interaction matrix and the time for LU factoring will be reduced by a factor of about 64. However, if a 1 were entered on the GE command the symmetry would be assumed to be destroyed by interaction with a ground plane, requiring storage of a 24 by 24 matrix.

```

GW 1 1 2. 0. 0. 1.84776 0.76537 0. 0.001
GM 0 1 0. 0. 22.5
GW 2 1 1. 0. 0. 0.70711 0.70711 0. 0.001
GR 0 8
GM 0 0 -90. 0. 0. 0. 0. 2.
GE

```

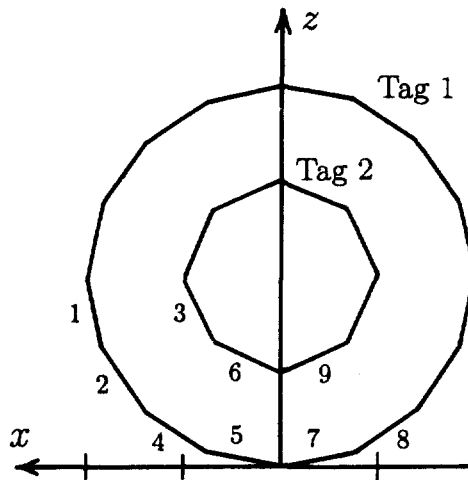

Fig. 17 Coaxial loops.

Linear Antenna Over a Wire Grid Plate

The following set of data define a dipole antenna over a wire grid plate as shown in figure 18:

```

GW 0 1 0. 0. 0. 0.1 0. 0. 0.001
GW 0 1 0. 0. 0. 0. 0.1 0. 0.001
GM 0 2 0. 0. 0. 0. 0.1 0.
GW 0 1 0. 0.3 0. 0.1 0.3 0. 0.001
GM 0 4 0. 0. 0. 0.1 0. 0.
GW 0 3 0.5 0. 0. 0.5 0.3 0. 0.001
GM 0 0 0. 0. 0. -0.25 -0.15 0.
GW 1 5 -0.23 0. 0.15 0.23 0. 0.15 0.001
GE

```

The first six commands generate data for the wire-grid plate, with the lower left-hand corner at the coordinate origin, by using GM commands to reproduce elemental sections of the grid. A GM command is then used to move the center of the plate to the origin. Finally, a wire is generated 0.15 meters above the plane with a tag of 1.

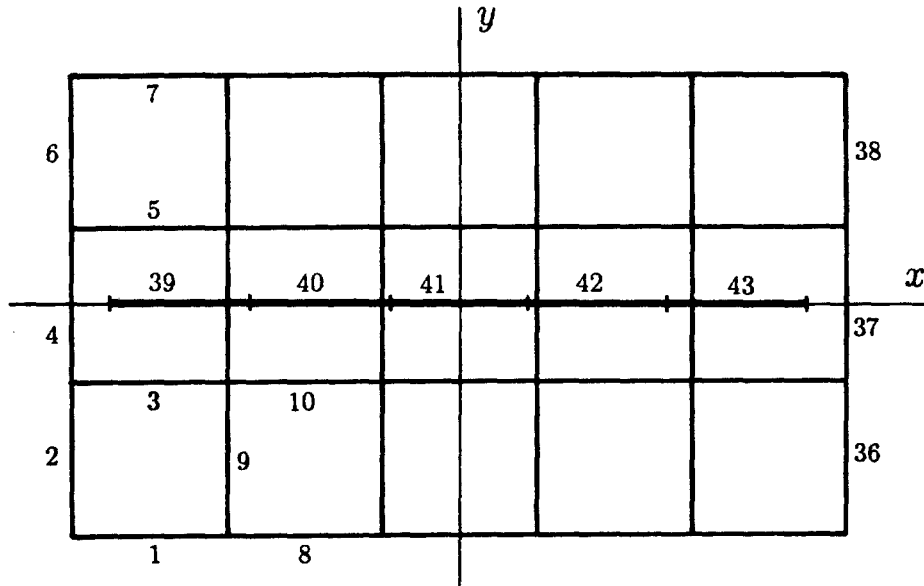

Fig. 18 Linear antenna over a wire-grid plate.

Cylinder with Attached Wires

The following data generate a patch model of a cylinder with two attached wires:

SP	0	0	10.	0.	-7.3333	0.	0.	38.4	
GM	0	2	0.	0.	0.	0.	0.	7.3333	
GM	0	1	0.	0.	30.				
SP	0	0	6.89	0.	11.	90.	0.	44.88	
SP	0	0	6.89	0.	-11.	-90.	0.	44.88	
GR	0	6							
SP	0	0	0.	0.	11.	90.	0.	44.89	
SP	0	0	0.	0.	-11.	-90.	0.	44.89	
GW	0	4	0.	0.	11.	0.	0.	23.	0.1
GW	0	5	10.	0.	0.	27.6	0.	0.	0.2
GS	0	0	0.01						
GE									

First a single patch is specified at the bottom, front of the cylinder, and is reproduced two times with z incremented. The resulting column of three patches is shown in figure 19a. A GM command is then used to produce a second column of patches rotated about the z axis by 30 degrees. A patch is added to the top and another to the bottom to form parts of the end surfaces. The model at this point is shown in figure 19b. Next a GR command is used to rotate this section of patches about the z axis to form a total of six similar sections, including the original. A patch is then added to the center of the top and another to the bottom to form the complete cylinder shown in figure 19c. Finally, two GW commands are used to add wires connecting to the top and side of the cylinder. The patches to which the wires connect are automatically divided into four smaller patches as shown in figure 19d. Although information about patch shape is not stored in the code, square patches are

assumed at the base of a connected wire when integrating over the surface current. Hence, a more appropriate representation of the model might be as shown in figure 20, where the patches to which wires connect are square, with equal areas maintained for all patches before the subdivision.

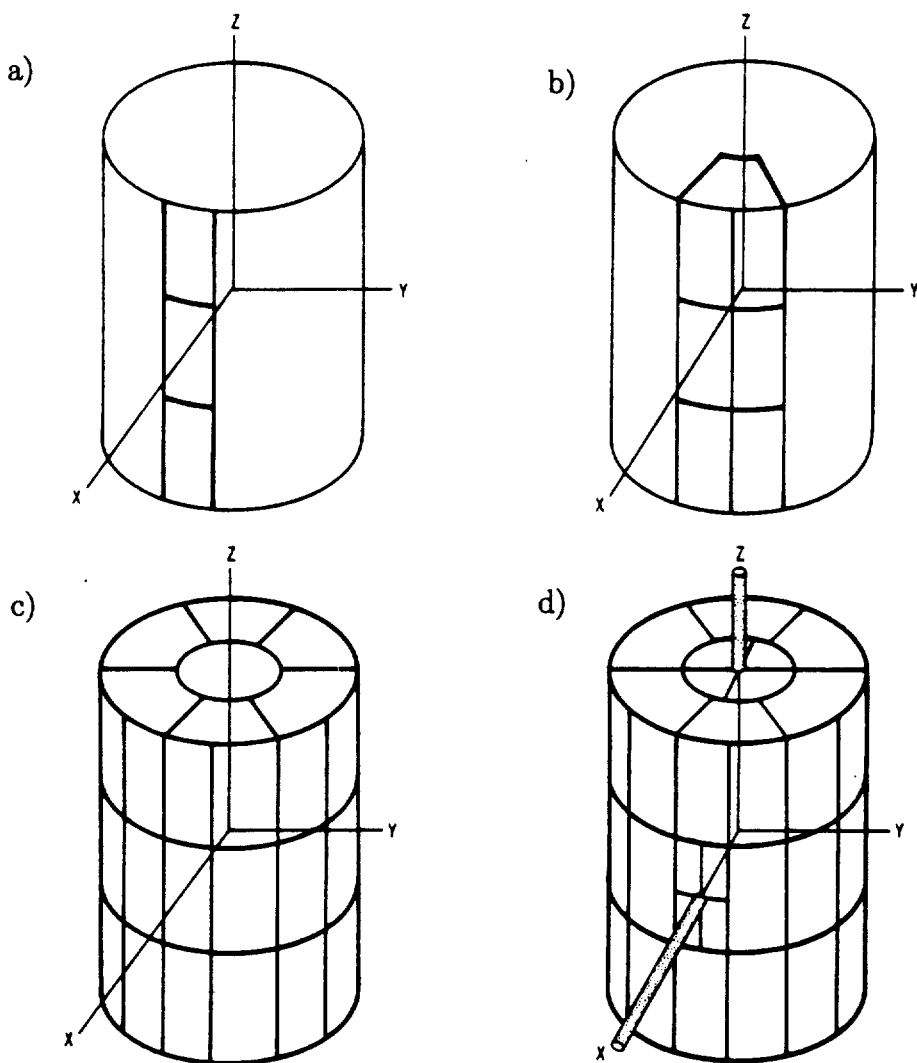

Fig. 19 Development of a surface model for a cylinder with attached wires.

3.5 Auxiliary Program SOMNTX

When the Sommerfeld integral option is requested on the GN command, NEC-4 needs a table of Sommerfeld integral values for the particular ground parameters and frequency used in the model. This table can be read from a file or generated by NEC-4. Since generating the table takes a moderate amount of CPU time, it is advantageous to generate the table as a file if the same ground parameters and frequency will be used more than once. A file with the

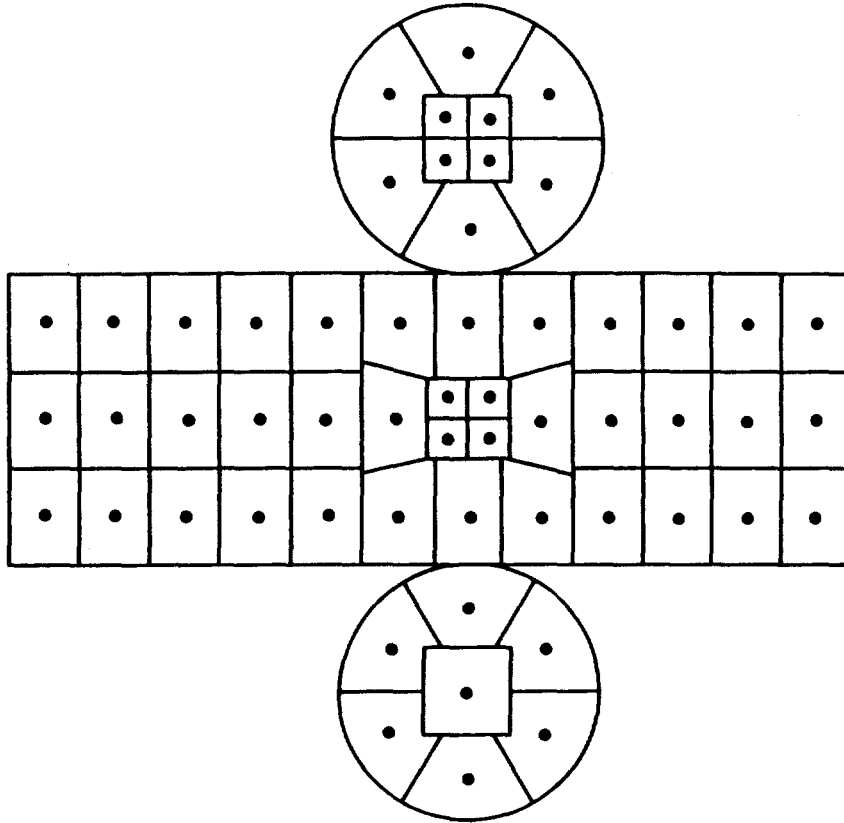

Fig. 20 Effective patch sizes when wires connect to the top and side of the cylinder.

Sommerfeld integral tables can be generated by running the auxiliary program SOMNTX4. SOMNTX4 is the same as the program SOMNTXS used with the single precision NEC-3, but the newer program allows the user to specify a name for the file.

SOMNTX4 reads a single line of data from the user's terminal. The input parameters are:

EPR SIG FMHZ [*File Name*]

where

EPR = relative dielectric constant of the ground, ϵ_r .

SIG = ground conductivity, σ (S/m).

FMHZ = frequency in MHz.

The file name should be separated from the data by a space or comma. If no file name is entered, the default name SOMS.NEC will be used.

ENTER EPR,SIG,FMHZ> 10. 0.01 5. SOMEX10.NEC

L.S. APPROX. DATA FILE:

EPSC= 1.00000E+01-3.59510E+01

	RHO:			ZZ:			ZP:		
REGION 1:	0.00000	0.60000		0.16370	2.00000		0.00000	0.25000	
PTS. FIT:	0.00000	0.20000	4	0.16370	0.20000	4	0.00000	0.06548	2
PTS. FIT:	0.00000	0.02500	5	0.16370	0.20000	2	0.00000	0.06548	2

NO. FUNCTIONS: 24 0
RMS RESIDUALS: 6.521E-05 9.648E-04 9.364E-05 9.611E-05 1.015E-04

	RHO:			ZZ:			ZP:		
REGION 2:	0.16370	0.60000		0.00000	0.24555		0.00000	0.25000	
PTS. FIT:	0.16370	0.10907	5	0.00000	0.08185	4	0.00000	0.06548	2
PTS. FIT:	0.16370	0.03274	6	0.00000	0.06548	2	0.00000	0.08185	3

NO. FUNCTIONS: 24 8
RMS RESIDUALS: 1.069E-03 1.497E-03 1.372E-03 1.498E-03 1.292E-03

	RHO:			ZZ:			ZP:		
REGION 3:	0.60000	2.00000		0.00000	2.00000		0.00000	0.25000	
PTS. FIT:	0.60000	0.20000	5	0.00000	0.20000	4	0.00000	0.06548	2
PTS. FIT:	0.60000	0.03274	8	0.00000	0.06548	2	0.00000	0.08185	3

NO. FUNCTIONS: 24 8
RMS RESIDUALS: 3.023E-04 8.133E-04 2.209E-04 5.624E-05 8.132E-04

FIELD EVALUATION TIME IN SOMLSQ 20.690 SECONDS
FIELD EVALUATION TIME IN SOMTRP 38.510 SECONDS

INTERPOLATION DATA FILE:

EPSC= 1.00000E+01-3.59510E+01

GRID	RHO:			ZZ:			ZP:		
1	0.00000E+00	1.63702E-02	11	0.00000E+00	2.33860E-02	8	0.00000E+00	1.63702E-02	5
2	0.00000E+00	1.63702E-02	11	0.00000E+00	4.09254E-02	5	6.05697E-02	2.57830E-02	5
3	0.00000E+00	4.09254E-02	5	0.00000E+00	5.45672E-02	4	1.55967E-01	2.11008E-01	5

TIME= 59.460 SECONDS

Fig. 21 Terminal output when running SOMNTX4 with $\epsilon_r = 10$, $\sigma = 0.01$ S/m and 5 MHz.

The Sommerfeld integral tables depend only on the complex dielectric constant

$$\tilde{\epsilon}_g = \epsilon_r - j\sigma/\omega\epsilon_0$$

where $\epsilon_r = \text{EPR}$ and $\sigma = \text{SIG}$. If SIG is input as a negative number the program sets

$$\tilde{\epsilon}_g = \text{EPR} - j|\text{SIG}|$$

and frequency is not used. The file generated by SOMNTX4 can be saved for use with any subsequent NEC-4 runs having the same ϵ_r and σ/ω or the same $\tilde{\epsilon}_g$.

As it runs, SOMNTX4 writes information on the terminal screen about the least-squares approximation and interpolation tables. Except for the indication of the accuracy provided by the residuals, this information is not of much interest to users. A sample output run on a VAX 6350 computer is shown in figure 21 for the input to SOMNTX of EPR = 10, SIG = 0.01 and frequency = 5 MHz.

Under the heading "L.S. APPROX. DATA FILE:" the value of $\tilde{\epsilon}_g$ is given first. Then, information is printed about the three regions over which least-squares approximation is used. After "REGION 1:" the ranges of radial separation (RHO), height (ZZ), and depth (-ZP) are printed for that region. The next two lines show the points at which the least-squares approximation is fit, giving initial value, increment and number of points in RHO, ZZ and ZP. Some of these values are fixed and some depend on $\tilde{\epsilon}_g$. After "NO. FUNCTIONS:" the first number is the number of functions used in the approximation that represent the ray traveling at a steep angle up to the interface and at a shallow angle in the upper medium. The second number is the number of functions for the ray that has a shallow angle in the lower medium.

The line labeled "RMS RESIDUALS:" provides an indication of how well the model was able to fit the computed field values in the least-squares approximation. The numbers are the rms residuals relative to the maximum magnitude for each of the five field components. The values will depend on $\tilde{\epsilon}_g$, and should be less than about 0.01.

Under "INTERPOLATION DATA FILE", the ranges of RHO, ZZ and ZP are printed for each of the three interpolation regions. These parameters depend on the value of $\tilde{\epsilon}_g$.

3.6 The Numerical Green's Function Option

With the Numerical Green's Function (NGF) option, a fixed structure and its environment can be modeled, and the factored interaction matrix saved on a file. New parts may then be added to the model in subsequent computer runs and the complete solution obtained without repeating calculations for the data on the file. The main purpose of the NGF is to avoid unnecessary repetition of calculations when a part of a model, such as a single antenna in a complex environment, will be modified one or more times while the environment remains fixed. For example, when modeling antennas on ships, several antenna designs or locations may be considered on an otherwise unchanged ship. With the NGF, the self-interaction matrix for the fixed environment may be computed, factored for solution and saved on a disk file. Solution for a new antenna then requires only the evaluation of the self-interaction matrix for the antenna, the mutual antenna-to-environment interactions and matrix manipulations for the partitioned-matrix solution. When the previously written NGF file is used, the free-space Green's function in the NEC formulation is, in effect, replaced by the Green's function for the environment.

Another reason for using the NGF option is to exploit partial symmetry in a structure. In a single run, a structure must be perfectly symmetric for NEC to use symmetry in the solution. Any unsymmetric segments or patches, or ones that lie in a symmetry plane or on the axis of rotation, will destroy the symmetry. Such partial symmetry may be exploited to reduce solution time by running the symmetric part of the model first and writing a NGF file. The unsymmetric parts may then be added in a second run.

Use of the NGF option may also be warranted for large, time-consuming models to save an expensive result for further use. Without adding new antennas, it may be used with a new excitation or to compute new radiation, near-field or coupling data not computed in the original run.

To write a NGF file for a structure, the input file is constructed as for a normal run. After the GE command, the frequency, ground parameters and loading may be set by FR, GN and LD commands. Other commands, such as EX or NT that do not change the matrix will not affect the NGF and will not be saved on the file. After the model has been defined, a WG command is used to fill and factor the matrix and cause the NGF data to be written to a file. Other commands may follow the WG command to define an excitation and request field calculations as in a normal run. WG should be the first command to request filling and factoring of the matrix, however, since it reserves array space for the matrix in subsequent runs when the NGF is used. Hence, WG should come before XQ, RP, NE or NH. The FR command must not specify multiple frequencies when a NGF is written.

To use a previously generated NGF file, the first command in the input file (except for CE or CM) must be GF to cause the program to read the NGF file. Subsequent structure data commands define the new structure to be added to the NGF structure. All types of structure geometry commands may be used, although GM, GR, GX and GS will affect new structure but not that from the NGF file. GR and GX will have their usual effect on the new structure but will not result in use of symmetry in the solution. Symmetry may be used in writing the NGF file but not for new structure used with the NGF.

For connections between the new structure and NGF structure, the new segment ends or patch centers must coincide with the NGF segment ends or patch centers as in a normal run. The rules still apply that only a single segment may connect to a given patch and a segment may have a patch connection on only one of its ends. Also, a wire may never connect to a patch formed by subdividing another patch for a previous connection.

Following the GE command, the program control commands may be used as usual with the exception that FR and GN commands may not be used. The parameters for FR and GN are taken from the NGF file and cannot be changed. LD commands may be used to load new segments but not segments in the NGF. If parameters I3 and I4 are zero on the LD command, the command will load all new segments, or new segments with tag LDTAG if I2 is not zero. NGF segments will not be loaded. If I2, I3 and I4 select a specific NGF segment, the run will terminate with an error message. The effect of loading on NGF segments may be obtained with a NT command, since NT (and TL) may connect to either new or NGF segments.

Computation time for a run using a NGF file will be approximately the time to model the complete structure minus the time to fill and factor the NGF matrix. If the new structure connects to the NGF structure, new unknowns in addition to those for the new segments and patches are produced, and should be included in time estimates for the complete structure. If a new segment or patch connects to a NGF segment, the current expansion function for the NGF segment is modified. One new unknown is then added to the matrix equation to represent the modified expansion function. If a new segment connects to a NGF patch, 10 new unknowns are produced in addition to that for the new segment. Four new patches are automatically generated at the connection point, accounting for eight unknowns. The remaining two new unknowns are needed to suppress the current on the old patch that has been replaced.

Although connection to a NGF segment modifies the old basis function, the current on the segment will be printed in its normal location in the table of segments. When a new wire connects to a NGF patch, the patch is divided into four new patches that will appear after the user-defined patches in the patch data. The original patch will be listed in the tables, but with nearly zero current. Also, the z coordinate of the original patch will be set to 9999.

4. NEC Output

The output of the NEC-4 program is described in this section and demonstrated in examples that exercise most of the options available in the code. A new user of NEC should read through the examples to see the types of output that are available, and also to learn the exact meanings of the quantities printed.

In addition to demonstrating the use of the code and typical output, the results may be used to check the operation of the code when it is put into use on a new computer system. The results shown here were produced on a DEC Alpha 3000/400 computer in double precision. Results obtained with different computer precision will differ somewhat, but NEC-4 should remain stable in single or double precision for most problems. In NEC-3 and earlier codes, precision could be lost when modeling electrically small wire objects, but this problem has been corrected in NEC-4. The results from NEC-4 will show small differences from those of NEC-3 or NEC-2, particularly with large wire radius, steps in radius or junctions, but NEC-4 should be at least as accurate as the earlier codes.

4.1 The Output File Format

The form of the output file follows the sequence of the input commands, starting with the structure-geometry data, and then model parameters and results of computations. The particular items printed will depend on the computations requested and options set by the input, but the basic form of the output is described below. Examples of the output discussed below can be found in Examples 1 through 4.

Structure-Geometry Data

The output for a given data set starts with the structure geometry data. Under the heading STRUCTURE SPECIFICATION is a list of the structure specification commands. The heading for the table is designed for a GW command, showing the x , y and z coordinates of the wire ends, the wire radius and the number of segments. Under the heading WIRE NO. is a count of the number of GW commands. The numbers of the starting and ending segments produced by the GW command are printed on the right-hand side of the page, along with the tag number assigned to each of these segments. Data from other structure commands are printed in the table with text identifying the command. For commands generating surface patches (SP or SM) the patch number is printed under WIRE NO. followed by a letter to indicate the shape option — P for the center-normal-area form, R for rectangular, T for triangular, and Q for quadrilateral. For other commands the data are printed within the table.

Summary of Wire-Segment Data

After a GE command is read, the program processes the structure-geometry data, searching for wire segments that connect to other wire segments, patches or a ground plane.

The segment data are then converted for internal storage to a form with the center point of the segment, orientation angles and segment lengths, as shown in figure 22.

The total number of segments and patches, number of segments and patches in a symmetric cell and symmetry flag are printed. The symmetry flag is zero for no symmetry, positive for planar symmetry and negative for rotational symmetry. A table of multiple-wire junctions lists any junctions at which three or more wires join. The number of each segment connecting to the junction is printed, as a positive number if the reference direction of the segment is into the junction or a negative number if the reference direction is out of the junction.

A summary of segment data is printed under the heading "SEGMENTATION DATA", with the elevation and azimuth angles α and β printed under the headings ALPHA and BETA. Also included in this table are connection data that show the conditions at both ends of each segment.

Segment Connection Data

Under the heading "CONNECTION DATA", the numbers under I- and I+ indicate the conditions at the first and second ends of segment number I, respectively. Segments connected at a junction can be located by tracing connection numbers through the table. After dropping the sign, the connection number under I- or I+ is the number of the segment connecting to the end of segment I. If the sign of the connection number is positive the segment reference directions are aligned (end 1 to end 2 or vice versa), and if the number is negative the reference directions are opposed (end 1 to end 1, or end 2 to end 2.) When more than one segment connects to a segment end, the connection number gives the next connected segment in the sequence of segments, searching cyclically through the list. For example, to find all segments connected to end 2 of segment 4 in the output of Example 4 (page ?), it is noted that $I_+(4) = 5$. Hence end 2 of segment 4 connects to end 1 of segment 5. Then going to segment 5, it is seen that $I_-(5) = -7$, so end 1 of segment 7 is connected to the junction. Then $I_-(7) = 4$, which indicates a connection to end 2 of segment 4, and completes the list since this was the starting point. Of course, an easier way to find the segments is to look in the list of multiple-wire junctions.

At a free end, where the segment end connects to nothing, the connection number is equal to zero. Thus free ends (sometimes due to an error in the input data) can be located by searching for zeros in the lists of connection numbers. If a segment end lies in the x - y plane

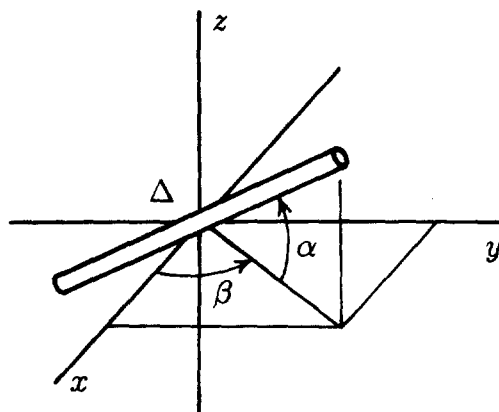

Fig. 22 Coordinates of a segment in terms of center point, length, elevation and azimuth angles.

and connection to a ground plane has been specified by entering a 1 as the first parameter on the GE command, then the connection number for that segment end will be equal to the segment number; that is, the segment connects to itself. This condition will force the derivative of current on the wire to be equal to zero at the end on the ground surface. This is an appropriate condition for a wire connecting to a perfectly conducting ground plane, and may be used with a finitely conducting ground as a crude approximation of a ground stake without actually modeling the wire in the ground. For an accurate solution for a ground stake, it is necessary to model the wire in the ground, however.

If a segment end was connected to a surface patch the connection number (I_{\pm}) will be greater than 10,000. The original patch will have been divided in to four patches, and $(I_{\pm}) - 10,000$ will be the number of the first of the four patches around the connection point.

Summary of Patch Data

When patches are used, a table headed "SURFACE PATCH DATA" will appear in the output showing the coordinates of each patch center, the components of the outward unit normal vector and the patch area. When patches have been entered as rectangles, triangles or quadrilaterals, the center point, normal and area will be computed in the code. The components of the unit tangent vectors, \hat{t}_1 and \hat{t}_2 are also printed for use in reading the surface currents which are printed later.

Model-Parameter Data

The input lines following the GE command are printed exactly as they are read by the program, following the label "***** INPUT LINE". When a command requesting computations is encountered, a summary of the model parameters is printed, followed by the computed results. The summary of model parameters includes frequency, ground parameters, impedance loads, network and transmission line data.

After a command requesting a solution is read, the code will compute the requested results. If it is necessary to fill and factor a new interaction matrix, the CPU times for these operations are printed under a heading "MATRIX TIMING."

Voltage Source Information

If one or more voltage sources have been specified, the voltage, current, input impedance and admittance and input power are printed for each source under the heading ANTENNA INPUT PARAMETERS. An example of this format can be found in Example 1. If the voltage source is the bicone type (EX 5, . . .) this is noted by "*" after the tag number in the table of input parameters (see Example 2.) Here, and else where in the output, the values printed for voltage, current and field represent peak values rather than rms. Hence power is computed as $P_{in} = \frac{1}{2} \text{Re}(VI^*)$.

Also, if voltage sources are used, a table titled POWER BUDGET will be printed after the listing of structure currents. The input power shown here is the total power supplied

by all voltage sources. The structure loss is ohmic loss in wires, while the network loss is the total power into all network and transmission-line ports, assuming no radiation from networks or transmission lines. If a wire has been insulated with a lossy sheath, the power dissipated in the sheath will also be printed. The radiated power is computed as the input power minus structure, network and insulation loss. This computation does not take into account power dissipated in a lossy ground. In order to obtain the radiated power for an antenna near ground, it is necessary to integrate the radiated field, using the "average gain" option on the RP command, as demonstrated in Example 4.

Segment and Patch Currents

Whenever a new solution for current is computed, the currents on all segments and patches are printed. The table of segment currents includes the coordinates of the segment centers and segment lengths normalized to wavelength. The currents are printed in real-imaginary and magnitude-phase forms. If the model includes patches, a table of patch currents is printed in a format giving the patch coordinates, the surface currents along the vectors \hat{t}_1 and \hat{t}_2 and the currents in x , y and z components.

Radiated Field, Gain and Near Field

Radiated fields or near fields requested in the input data are printed following the current tables. If the structure is excited by a voltage source, the radiated-field table will include the antenna gains — either power gain or directive gain (directivity), as requested on the RP command. If the excitation is by an incident plane wave, the table will show the normalized scattering cross section σ/λ^2 in dB. If mixed excitation types are used, the output format will be determined by the last excitation in the set of EX commands. For very small gains or cross sections, the number -999.99 dB is printed.

The radiation-pattern format also includes the radiated electric field in θ and ϕ components. If the range R to the evaluation point has been specified on the RP command, the field components are printed in units of volts per meter. However, if the range has not been specified, the quantities $RE_\theta(R, \theta, \phi)$ and $RE_\phi(R, \theta, \phi)$ for $R \rightarrow \infty$ are printed in units of volts. The polarization is printed in a format for general elliptic polarization, including axial ratio (minor axis/major axis), tilt angle of the major axis (η in figure 9), and sense of rotation (right-hand, left-hand or linear.) The sense refers to the thumb pointing in the direction of the wave propagation.

In addition to these basic formats, there are a number of special formats for optional calculations. Many of these occur in the following examples.

4.2 Examples of NEC Output

The examples in this section are simple modeling problems that demonstrate most of the output features of NEC-4. The correct interpretation of the output is explained when necessary. Also, these examples may be useful to a new user of NEC in demonstrating

ways to use the code and to set up input files. The results were produced on a DEC Alpha 3000/400 computer in 64-bit double precision.

4.2.1 Examples 1 through 4

Examples 1 through 4 are simple cases intended to illustrate the basic formats. In Example 1, a $\lambda/2$ dipole is excited at its center. The XQ command requests only the calculation of current. After "ANTENNA INPUT PARAMETERS", a table shows the value of current at the center of each segment. Next, the antenna is loaded at its center with a series R-L-C circuit. Since the load coincides with the source segment, the effect on input impedance is simply to add the load impedance in series. If the load had been on another segment, the effect on input impedance would have been more complex.

The PQ command requests a listing of the linear charge density at the center of each segment. In addition, the charge density is printed at the free ends of segments 1 and 7, with "E" following the segment number to indicate a free wire end. The values obtained for charge density at wire ends will be very dependent on the segment lengths. As more segments are added to reduce the segment lengths, the charge densities at the ends will increase, approaching the singular behavior expected at an edge. However, the values printed give some indication of the charge in the vicinity of the end.

The NE commands request computation of near electric fields, first along the wire axis and then along the wire surface. Ideally, the z component of electric field would be zero along the wire axis and on the surface, except over the source region. On the wire axis the field is very small at the centers of segments away from the source, since these values are enforced in the moment-method solution. When the field is evaluated along the wire surface, the z component is small, but considerably larger than on the axis. Evaluating the z component of field on the wire surface is the worst case for the thin-wire approximation in NEC-4. This calculation illustrates a difference between NEC-4 and NEC-3. In NEC-3, the solution was obtained by matching the boundary condition on the wire surface, with the current treated as a filament on the axis. Hence NEC-3 would give very small tangential fields on the surface at the match points. When the near field is requested at a point on the wire axis in NEC-3, it is actually computed on the wire surface. The radial electric field (E_x) computed on the wire surface can be compared with the charge densities at the segment centers. For charge density ρ and wire radius a the field is $E_x = \rho/2\pi a\epsilon_0$.

In Example 2 the wire has an even number of segments, so a bicone voltage source model has been used to excite the wire at its center. The symbol "*" in the table of antenna input parameters is a reminder that this type of source has been used. The wire radius is very small for this problem, since the bicone source is only accurate for thin wires and small radius to segment-length ratios. A safer way to excite the center of this wire would be to use applied-field voltage sources on segments 4 and 5, each with half of the total voltage.

Three frequencies are run in Example 2, and the option on the EX command is used to collect and normalize the input impedances. At the end of Example 2, the wire is given the conductivity of aluminum. This has a significant effect, since the wire is relatively thin.

Example 3 is a vertical dipole over ground. The average power gain has been computed using the option on the RP command. For the first result, with perfectly-conducting ground, the average gain is close to the ideal value of 2. For a more complex structure, the average gain can provide a check on the accuracy of the computed input impedance. The value of average gain should be 1.0 for a model in free space and 2.0 over perfectly conducting ground. Acceptable differences from the correct value may range from a few percent for a simple model to ten percent or more for large, complex models.

Example 3 also includes a solution for finitely conducting ground using the reflection-coefficient approximation. With a finitely conducting ground the average gain cannot be used as a check on solution accuracy, but shows the radiation efficiency of the antenna, taking into account ground loss. Since the average gain has dropped from 2.0 for perfectly conducting ground to 0.72, the radiation efficiency is 36 percent.

Example 4 is a simple model to demonstrate the connection of a wire to a surface patch. Although the structure is over a perfectly conducting ground, a value of 1.8 is obtained for average gain. This result indicates that the input impedance is inaccurate, probably due to the crude patch model used for the box. In a case such as this, the average gain can be used to compute corrected values for the radiated power, input resistance and antenna gain. The total radiated power from integrating the radiated field, $9.623(10^{-4})$ watts, is printed after the average gain. In earlier versions of NEC, this value must be obtained by multiplying the average gain by the total input power. The radiation resistance can then be computed as

$$\begin{aligned}\text{Radiation resistance} &= 2 \times (\text{radiated power}) / |I_{\text{source}}|^2 \\ &= 167.8 \text{ ohms}\end{aligned}$$

where I_{source} is the source current, and the factor of 2 is necessary because values printed by NEC for current, voltage and field are peak rather than rms. Since the value of input power used in computing gains for the radiation pattern table is too large by 0.46 dB ($10 \log_{10}[2/1.8]$), the gains can be corrected by adding this amount.

Input for Examples 1 through 4

```

CEEXAMPLE 1.  CENTER FED LINEAR ANTENNA
GW 0 7 0. 0. -.25 0. 0. .25 .001
GE
EX 0 0 4 0 1.
XQ
LD 0 0 4 4 10. 3.000E-09 5.300E-11
PQ
NE 0 1 1 15 0. 0. 0. 0. .01786
NE 0 1 1 15 .001 0. 0. 0. 0. .01786
NX
CMEXAMPLE 2.  CENTER FED LINEAR ANTENNA.
CM CURRENT SLOPE DISCONTINUITY SOURCE.
CM 1. THIN PERFECTLY CONDUCTING WIRE
CE 2. THIN ALUMINUM WIRE
GW 0 8 0. 0. -.25 0. 0. .25 .00001
GE
FR 0 3 0 0 200. 50.
EX 5 0 5 1 1. 0. 50.
XQ
LD 5 0 0 0 3.720E+07
FR 0 1 0 0 300.
EX 5 0 5 0 1.
XQ
NX
CMEXAMPLE 3.  VERTICAL HALF WAVELENGTH ANTENNA OVER GROUND
CM 1. PERFECT GROUND
CM 2. IMPERFECT GROUND INCLUDING GROUND WAVE AND RECEIVING
CE PATTERN CALCULATIONS
GW 0 9 0. 0. 2. 0. 0. 7. .3
GE 1
FR 0 1 0 0 30.
EX 0 0 5 0 1.
GN 1
RP 0 10 2 1301 0. 0. 10. 90.
GN 0 0 0 0 6. 1.000E-03
RP 0 10 2 1301 0. 0. 10. 90.
RP 1 10 1 0 1. 0. 2. 0. 1.000E+05
EX 1 10 1 0 0. 0. 0. 10.
PT 2 0 5 5
XQ
NX
CEEXAMPLE 4.  T ANTENNA ON A BOX OVER PERFECT GROUND
SP 0 0 .1 .05 .05 0. 0. .01
SP 0 0 .05 .1 .05 0. 90. .01
GX 0 110
SP 0 0 0. 0. .1 90. 0. .04
GW 1 4 0. 0. .1 0. 0. .3 .001
GW 2 2 0. 0. .3 .15 0. .3 .001
GW 3 2 0. 0. .3 -.15 0. .3 .001
GE 1
GN 1
EX 0 1 1 0 1.
RP 0 10 4 1001 0. 0. 10. 30.
EN

```

Output for Examples 1 through 4

 *
 * NUMERICAL ELECTROMAGNETICS CODE (NEC-4.1) *
 *

 EXAMPLE 1. CENTER FED LINEAR ANTENNA

- - - STRUCTURE SPECIFICATION - - -

COORDINATES MUST BE INPUT IN
 METERS OR BE SCALED TO METERS
 BEFORE STRUCTURE INPUT IS ENDED

WIRE NO.	X1	Y1	Z1	X2	Y2	Z2	RADIUS	NO. OF SEG.	FIRST SEG.	LAST SEG.	TAG NO.
1	0.00000	0.00000	-0.25000	0.00000	0.00000	0.25000	0.00100	7	1	7	0

TOTAL SEGMENTS USED= 7 NO. SEG. IN A SYMMETRIC CELL= 7 SYMMETRY FLAG= 0

- MULTIPLE WIRE JUNCTIONS -
 JUNCTION SEGMENTS (- FOR END 1, + FOR END 2)
 NONE

- - - - SEGMENTATION DATA - - - -

COORDINATES IN METERS

I+ AND I- INDICATE THE SEGMENTS BEFORE AND AFTER I

SEG. NO.	COORDINATES OF SEG. CENTER			SEG. LENGTH	ORIENTATION ANGLES		WIRE RADIUS	CONNECTION DATA			TAG NO.
	X	Y	Z		ALPHA	BETA		I-	I	I+	
1	0.00000	0.00000	-0.21429	0.07143	90.00000	0.00000	0.00100	0	1	2	0
2	0.00000	0.00000	-0.14286	0.07143	90.00000	0.00000	0.00100	1	2	3	0
3	0.00000	0.00000	-0.07143	0.07143	90.00000	0.00000	0.00100	2	3	4	0
4	0.00000	0.00000	0.00000	0.07143	90.00000	0.00000	0.00100	3	4	5	0
5	0.00000	0.00000	0.07143	0.07143	90.00000	0.00000	0.00100	4	5	6	0
6	0.00000	0.00000	0.14286	0.07143	90.00000	0.00000	0.00100	5	6	7	0
7	0.00000	0.00000	0.21429	0.07143	90.00000	0.00000	0.00100	6	7	0	0

***** INPUT LINE 1 EX 0 0 4 0 1.00000E+00 0.00000E+00 0.00000E+00 0.00000E+00 0.00000E+00 0.00000E+00
 ***** INPUT LINE 2 XQ 0 0 0 0 0.00000E+00 0.00000E+00 0.00000E+00 0.00000E+00 0.00000E+00 0.00000E+00

- - - - - FREQUENCY - - - - -

FREQUENCY= 2.9980E+02 MHZ
 WAVELENGTH= 1.0000E+00 METERS

- - - ANTENNA ENVIRONMENT - - -

FREE SPACE

- - - STRUCTURE IMPEDANCE LOADING - - -

THIS STRUCTURE IS NOT LOADED

- - - MATRIX TIMING - - -

FILL= 0.010 SEC., FACTOR= 0.000 SEC.

- - - ANTENNA INPUT PARAMETERS - - -

TAG NO.	SEG. NO.	VOLTAGE (VOLTS)		CURRENT (AMPS)		IMPEDANCE (OHMS)		ADMITTANCE (MHOS)		POWER (WATTS)
		REAL	IMAG.	REAL	IMAG.	REAL	IMAG.	REAL	IMAG.	
0	4	1.00000E+00	0.00000E+00	9.20578E-03	-5.15456E-03	8.26996E+01	4.63057E+01	9.20578E-03	-5.15456E-03	4.60289E-03

- - - CURRENTS AND LOCATION - - -

LENGTHS NORMALIZED BY WAVELENGTH (OR 2.*PI/CABS(K))

SEG. NO.	TAG NO.	COORD. OF SEG. CENTER			SEG. LENGTH	CURRENT (AMPS)			PHASE
		X	Y	Z		REAL	IMAG.	MAG.	
1	0	0.0000	0.0000	-0.2143	0.07143	2.3592E-03	-1.6880E-03	2.9009E-03	-35.584
2	0	0.0000	0.0000	-0.1429	0.07143	5.9998E-03	-4.0462E-03	7.2366E-03	-33.995
3	0	0.0000	0.0000	-0.0714	0.07143	8.3711E-03	-5.1856E-03	9.8471E-03	-31.777
4	0	0.0000	0.0000	0.0000	0.07143	9.2058E-03	-5.1546E-03	1.0551E-02	-29.246
5	0	0.0000	0.0000	0.0714	0.07143	8.3711E-03	-5.1856E-03	9.8471E-03	-31.777
6	0	0.0000	0.0000	0.1429	0.07143	5.9998E-03	-4.0462E-03	7.2366E-03	-33.995
7	0	0.0000	0.0000	0.2143	0.07143	2.3592E-03	-1.6880E-03	2.9009E-03	-35.584

- - - POWER BUDGET - - -

INPUT POWER = 4.6029E-03 WATTS
 RADIATED POWER= 4.6029E-03 WATTS
 WIRE LOSS = 0.0000E+00 WATTS
 EFFICIENCY = 100.00 PERCENT

***** INPUT LINE 3 LD 0 0 4 4 1.00000E+01 3.00000E-09 5.30000E-11 0.00000E+00 0.00000E+00 0.00000E+00
 ***** INPUT LINE 4 PQ 0 0 0 0 0.00000E+00 0.00000E+00 0.00000E+00 0.00000E+00 0.00000E+00 0.00000E+00
 ***** INPUT LINE 5 NE 0 1 1 15 0.00000E+00 0.00000E+00 0.00000E+00 0.00000E+00 0.00000E+00 1.78600E-02

- - - - - FREQUENCY - - - - -

FREQUENCY= 2.9980E+02 MHZ
 WAVELENGTH= 1.0000E+00 METERS

- - - ANTENNA ENVIRONMENT - - -

FREE SPACE

- - - STRUCTURE IMPEDANCE LOADING - - -

LOCATION ITAG FROM THRU	RESISTANCE OHMS	INDUCTANCE HENRYS	CAPACITANCE FARADS	IMPEDANCE (OHMS)		CONDUCTIVITY MHOS/METER	TYPE
				REAL	IMAGINARY		
4 4	1.0000E+01	3.0000E-09	5.3000E-11				SERIES

- - - MATRIX TIMING - - -

FILL= 0.000 SEC., FACTOR= 0.000 SEC.

- - - ANTENNA INPUT PARAMETERS - - -

TAG NO.	SEG. NO.	VOLTAGE (VOLTS)		CURRENT (AMPS)		IMPEDANCE (OHMS)		ADMITTANCE (MHOS)		POWER (WATTS)
		REAL	IMAG.	REAL	IMAG.	REAL	IMAG.	REAL	IMAG.	
0	4	1.00000E+00	0.00000E+00	8.95457E-03	-4.05135E-03	9.26996E+01	4.19404E+01	8.95457E-03	-4.05135E-03	4.47729E-03

- - - CURRENTS AND LOCATION - - -

LENGTHS NORMALIZED BY WAVELENGTH (OR 2.*PI/CABS(K))

SEG. NO.	TAG NO.	COORD. OF SEG. CENTER			SEG. LENGTH	CURRENT (AMPS)			PHASE
		X	Y	Z		REAL	IMAG.	MAG.	
1	0	0.0000	0.0000	-0.2143	0.07143	2.3240E-03	-1.3789E-03	2.7023E-03	-30.682
2	0	0.0000	0.0000	-0.1429	0.07143	5.8907E-03	-3.2778E-03	6.7413E-03	-29.093
3	0	0.0000	0.0000	-0.0714	0.07143	8.1823E-03	-4.1466E-03	9.1730E-03	-26.875
4	0	0.0000	0.0000	0.0000	0.07143	8.9546E-03	-4.0513E-03	9.8284E-03	-24.344
5	0	0.0000	0.0000	0.0714	0.07143	8.1823E-03	-4.1466E-03	9.1730E-03	-26.875
6	0	0.0000	0.0000	0.1429	0.07143	5.8907E-03	-3.2778E-03	6.7413E-03	-29.093
7	0	0.0000	0.0000	0.2143	0.07143	2.3240E-03	-1.3789E-03	2.7023E-03	-30.682

- - - CHARGE DENSITIES - - -

LENGTHS NORMALIZED TO WAVELENGTH (OR 2.*PI/CABS(K))

SEG. NO.	TAG NO.	COORD. OF SEG. CENTER			SEG. LENGTH	CHARGE DENSITY (COULOMBS/METER)			PHASE
		X	Y	Z		REAL	IMAG.	MAG.	
1E	0	0.0000	0.0000	-0.2500	0.07143	2.1919E-11	3.6035E-11	4.2178E-11	58.690
1	0	0.0000	0.0000	-0.2143	0.07143	1.8291E-11	3.1761E-11	3.6651E-11	60.062
2	0	0.0000	0.0000	-0.1429	0.07143	1.0429E-11	2.2040E-11	2.4383E-11	64.677
3	0	0.0000	0.0000	-0.0714	0.07143	2.1138E-12	1.1638E-11	1.1829E-11	79.706
4	0	0.0000	0.0000	0.0000	0.07143	-5.7863E-27	-1.1573E-26	1.2938E-26	-116.565
5	0	0.0000	0.0000	0.0714	0.07143	-2.1138E-12	-1.1638E-11	1.1829E-11	-100.294
6	0	0.0000	0.0000	0.1429	0.07143	-1.0429E-11	-2.2040E-11	2.4383E-11	-115.323
7	0	0.0000	0.0000	0.2143	0.07143	-1.8291E-11	-3.1761E-11	3.6651E-11	-119.938
7E	0	0.0000	0.0000	0.2500	0.07143	-2.1919E-11	-3.6035E-11	4.2178E-11	-121.310

- - - POWER BUDGET - - -

INPUT POWER = 4.4773E-03 WATTS
 RADIATED POWER= 3.9943E-03 WATTS
 WIRE LOSS = 4.8299E-04 WATTS
 EFFICIENCY = 89.21 PERCENT

- - - NEAR ELECTRIC FIELDS - - -

- LOCATION -			- EX -		- EY -		- EZ -	
X METERS	Y METERS	Z METERS	MAGNITUDE VOLTS/M	PHASE DEGREES	MAGNITUDE VOLTS/M	PHASE DEGREES	MAGNITUDE VOLTS/M	PHASE DEGREES
0.0000	0.0000	0.0000	0.0000E+00	0.00	0.0000E+00	0.00	1.3042E+01	-175.10
0.0000	0.0000	0.0179	0.0000E+00	0.00	0.0000E+00	0.00	1.2536E+01	-175.08
0.0000	0.0000	0.0357	0.0000E+00	0.00	0.0000E+00	0.00	6.7270E+00	-175.46
0.0000	0.0000	0.0536	0.0000E+00	0.00	0.0000E+00	0.00	8.4348E-01	-179.75
0.0000	0.0000	0.0714	0.0000E+00	0.00	0.0000E+00	0.00	3.2912E-04	-4.14
0.0000	0.0000	0.0893	0.0000E+00	0.00	0.0000E+00	0.00	3.4488E-01	-8.87
0.0000	0.0000	0.1072	0.0000E+00	0.00	0.0000E+00	0.00	2.7987E-01	22.84
0.0000	0.0000	0.1250	0.0000E+00	0.00	0.0000E+00	0.00	2.2073E-01	74.43
0.0000	0.0000	0.1429	0.0000E+00	0.00	0.0000E+00	0.00	3.2422E-04	-106.81
0.0000	0.0000	0.1607	0.0000E+00	0.00	0.0000E+00	0.00	2.1940E-01	-106.43
0.0000	0.0000	0.1786	0.0000E+00	0.00	0.0000E+00	0.00	1.9747E+00	57.57
0.0000	0.0000	0.1965	0.0000E+00	0.00	0.0000E+00	0.00	3.3108E+00	58.63
0.0000	0.0000	0.2143	0.0000E+00	0.00	0.0000E+00	0.00	1.0230E-02	-121.55
0.0000	0.0000	0.2322	0.0000E+00	0.00	0.0000E+00	0.00	1.0677E+01	-121.66
0.0000	0.0000	0.2500	0.0000E+00	0.00	0.0000E+00	0.00	7.3668E+02	-121.37

***** INPUT LINE 6 NE 0 1 1 15 1.00000E-03 0.00000E+00 0.00000E+00 0.00000E+00 0.00000E+00 1.78600E-02

- - - NEAR ELECTRIC FIELDS - - -

- LOCATION -			- EX -		- EY -		- EZ -	
X	Y	Z	MAGNITUDE	PHASE	MAGNITUDE	PHASE	MAGNITUDE	PHASE
METERS	METERS	METERS	VOLTS/M	DEGREES	VOLTS/M	DEGREES	VOLTS/M	DEGREES
0.0010	0.0000	0.0000	2.9570E-13	-114.12	0.0000E+00	0.00	1.2068E+01	-175.57
0.0010	0.0000	0.0179	5.5432E+01	-66.34	0.0000E+00	0.00	1.1563E+01	-175.56
0.0010	0.0000	0.0357	1.0947E+02	-67.51	0.0000E+00	0.00	6.3682E+00	-176.30
0.0010	0.0000	0.0536	1.5608E+02	-88.87	0.0000E+00	0.00	1.0985E+00	177.07
0.0010	0.0000	0.0714	2.1267E+02	-100.31	0.0000E+00	0.00	2.6119E-01	166.81
0.0010	0.0000	0.0893	2.7146E+02	-106.86	0.0000E+00	0.00	8.6233E-02	4.26
0.0010	0.0000	0.1072	3.2922E+02	-111.07	0.0000E+00	0.00	1.3831E-01	77.44
0.0010	0.0000	0.1250	3.8591E+02	-113.51	0.0000E+00	0.00	2.5106E-01	124.56
0.0010	0.0000	0.1429	4.3834E+02	-115.33	0.0000E+00	0.00	2.0187E-01	-178.22
0.0010	0.0000	0.1607	4.8562E+02	-116.77	0.0000E+00	0.00	3.4158E-01	-140.60
0.0010	0.0000	0.1786	5.2835E+02	-117.97	0.0000E+00	0.00	1.5253E+00	63.32
0.0010	0.0000	0.1965	5.9658E+02	-119.06	0.0000E+00	0.00	2.5345E+00	62.10
0.0010	0.0000	0.2143	6.5864E+02	-119.94	0.0000E+00	0.00	8.0360E-01	-132.39
0.0010	0.0000	0.2322	7.1183E+02	-120.67	0.0000E+00	0.00	1.1430E+01	-122.41
0.0010	0.0000	0.2500	6.2614E+02	-121.28	0.0000E+00	0.00	2.7833E+02	-121.49

***** INPUT LINE 7 NX 0 0 0 0 0.00000E+00 0.00000E+00 0.00000E+00 0.00000E+00 0.00000E+00 0.00000E+00

 * NUMERICAL ELECTROMAGNETICS CODE (NEC-4.1) *

 EXAMPLE 2. CENTER FED LINEAR ANTENNA.
 CURRENT SLOPE DISCONTINUITY SOURCE.
 1. THIN PERFECTLY CONDUCTING WIRE
 2. THIN ALUMINUM WIRE

- - - STRUCTURE SPECIFICATION - - -

COORDINATES MUST BE INPUT IN METERS OR BE SCALED TO METERS BEFORE STRUCTURE INPUT IS ENDED

WIRE NO.	X1	Y1	Z1	X2	Y2	Z2	RADIUS	NO. OF SEG.	FIRST SEG.	LAST SEG.	TAG NO.
1	0.00000	0.00000	-0.25000	0.00000	0.00000	0.25000	0.00001	8	1	8	0
TOTAL SEGMENTS USED=		8	NO. SEG. IN A SYMMETRIC CELL=		8	SYMMETRY FLAG=		0			

- MULTIPLE WIRE JUNCTIONS -
 JUNCTION SEGMENTS (- FOR END 1, + FOR END 2)
 NONE

- - - - SEGMENTATION DATA - - - -

COORDINATES IN METERS

I+ AND I- INDICATE THE SEGMENTS BEFORE AND AFTER I

SEG. NO.	COORDINATES OF SEG. CENTER			SEG. LENGTH	ORIENTATION ANGLES		WIRE RADIUS	CONNECTION DATA			TAG NO.
	X	Y	Z		ALPHA	BETA		I-	I	I+	
1	0.00000	0.00000	-0.21875	0.06250	90.00000	0.00000	0.00001	0	1	2	0
2	0.00000	0.00000	-0.15625	0.06250	90.00000	0.00000	0.00001	1	2	3	0
3	0.00000	0.00000	-0.09375	0.06250	90.00000	0.00000	0.00001	2	3	4	0
4	0.00000	0.00000	-0.03125	0.06250	90.00000	0.00000	0.00001	3	4	5	0
5	0.00000	0.00000	0.03125	0.06250	90.00000	0.00000	0.00001	4	5	6	0
6	0.00000	0.00000	0.09375	0.06250	90.00000	0.00000	0.00001	5	6	7	0
7	0.00000	0.00000	0.15625	0.06250	90.00000	0.00000	0.00001	6	7	8	0
8	0.00000	0.00000	0.21875	0.06250	90.00000	0.00000	0.00001	7	8	0	0

*****	INPUT LINE	1	FR	0	3	0	0	2.00000E+02	5.00000E+01	0.00000E+00	0.00000E+00	0.00000E+00	0.00000E+00
*****	INPUT LINE	2	EX	5	0	5	1	1.00000E+00	0.00000E+00	5.00000E+01	0.00000E+00	0.00000E+00	0.00000E+00
*****	INPUT LINE	3	XQ	0	0	0	0	0.00000E+00	0.00000E+00	0.00000E+00	0.00000E+00	0.00000E+00	0.00000E+00

- - - - - FREQUENCY - - - - -

FREQUENCY= 2.0000E+02 MHZ
 WAVELENGTH= 1.4990E+00 METERS

- - - ANTENNA ENVIRONMENT - - -

FREE SPACE

- - - STRUCTURE IMPEDANCE LOADING - - -

THIS STRUCTURE IS NOT LOADED

- - - MATRIX TIMING - - -

FILL= 0.000 SEC., FACTOR= 0.000 SEC.

- - - ANTENNA INPUT PARAMETERS - - -

TAG NO.	SEG. NO.	VOLTAGE (VOLTS)		CURRENT (AMPS)		IMPEDANCE (OHMS)		ADMITTANCE (MHOS)		POWER (WATTS)
		REAL	IMAG.	REAL	IMAG.	REAL	IMAG.	REAL	IMAG.	
0 *	5	1.00000E+00	0.00000E+00	6.64063E-05	1.57933E-03	2.65762E+01	-6.32060E+02	6.64063E-05	1.57933E-03	3.32031E-05

- - - CURRENTS AND LOCATION - - -

LENGTHS NORMALIZED BY WAVELENGTH (OR 2.*PI/CABS(K))

SEG. NO.	TAG NO.	COORD. OF SEG. CENTER			SEG. LENGTH	CURRENT (AMPS)			PHASE
		X	Y	Z		REAL	IMAG.	MAG.	
1	0	0.0000	0.0000	-0.1459	0.04169	1.5369E-05	2.5220E-04	2.5267E-04	86.513
2	0	0.0000	0.0000	-0.1042	0.04169	3.9856E-05	7.0589E-04	7.0702E-04	86.768
3	0	0.0000	0.0000	-0.0625	0.04169	5.6673E-05	1.1008E-03	1.1023E-03	87.053
4	0	0.0000	0.0000	-0.0208	0.04169	6.5314E-05	1.4319E-03	1.4334E-03	87.388
5	0	0.0000	0.0000	0.0208	0.04169	6.5314E-05	1.4319E-03	1.4334E-03	87.388
6	0	0.0000	0.0000	0.0625	0.04169	5.6673E-05	1.1008E-03	1.1023E-03	87.053
7	0	0.0000	0.0000	0.1042	0.04169	3.9856E-05	7.0589E-04	7.0702E-04	86.768
8	0	0.0000	0.0000	0.1459	0.04169	1.5369E-05	2.5220E-04	2.5267E-04	86.513

- - - POWER BUDGET - - -

INPUT POWER = 3.3203E-05 WATTS
 RADIATED POWER= 3.3203E-05 WATTS
 WIRE LOSS = 0.0000E+00 WATTS
 EFFICIENCY = 100.00 PERCENT

- - - - - FREQUENCY - - - - -

FREQUENCY= 2.5000E+02 MHZ
 WAVELENGTH= 1.1992E+00 METERS

- - - ANTENNA ENVIRONMENT - - -

FREE SPACE

- - - STRUCTURE IMPEDANCE LOADING - - -

THIS STRUCTURE IS NOT LOADED

- - - MATRIX TIMING - - -

FILL= 0.010 SEC., FACTOR= 0.000 SEC.

- - - ANTENNA INPUT PARAMETERS - - -

TAG NO.	SEG. NO.	VOLTAGE (VOLTS)		CURRENT (AMPS)		IMPEDANCE (OHMS)		ADMITTANCE (MHOS)		POWER (WATTS)
		REAL	IMAG.	REAL	IMAG.	REAL	IMAG.	REAL	IMAG.	
0 *	5	1.00000E+00	0.00000E+00	6.16989E-04	3.56466E-03	4.71435E+01	-2.72372E+02	6.16989E-04	3.56466E-03	3.08494E-04

- - - CURRENTS AND LOCATION - - -

LENGTHS NORMALIZED BY WAVELENGTH (OR 2.*PI/CABS(K))

SEG. NO.	TAG NO.	COORD. OF SEG. CENTER			SEG. LENGTH	CURRENT (AMPS)			PHASE
		X	Y	Z		REAL	IMAG.	MAG.	
1	0	0.0000	0.0000	-0.1824	0.05212	1.3629E-04	6.4701E-04	6.6120E-04	78.105
2	0	0.0000	0.0000	-0.1303	0.05212	3.6169E-04	1.7863E-03	1.8225E-03	78.553
3	0	0.0000	0.0000	-0.0782	0.05212	5.2216E-04	2.7057E-03	2.7557E-03	79.077
4	0	0.0000	0.0000	-0.0261	0.05212	6.0628E-04	3.3503E-03	3.4047E-03	79.743
5	0	0.0000	0.0000	0.0261	0.05212	6.0628E-04	3.3503E-03	3.4047E-03	79.743
6	0	0.0000	0.0000	0.0782	0.05212	5.2216E-04	2.7057E-03	2.7557E-03	79.077
7	0	0.0000	0.0000	0.1303	0.05212	3.6169E-04	1.7863E-03	1.8225E-03	78.553
8	0	0.0000	0.0000	0.1824	0.05212	1.3629E-04	6.4701E-04	6.6120E-04	78.105

- - - POWER BUDGET - - -

INPUT POWER = 3.0849E-04 WATTS
 RADIATED POWER = 3.0849E-04 WATTS
 WIRE LOSS = 0.0000E+00 WATTS
 EFFICIENCY = 100.00 PERCENT

- - - - - FREQUENCY - - - - -

FREQUENCY = 3.0000E+02 MHZ
 WAVELENGTH = 9.9933E-01 METERS

- - - ANTENNA ENVIRONMENT - - -

FREE SPACE

- - - STRUCTURE IMPEDANCE LOADING - - -

THIS STRUCTURE IS NOT LOADED

- - - MATRIX TIMING - - -

FILL = 0.000 SEC., FACTOR = 0.000 SEC.

- - - ANTENNA INPUT PARAMETERS - - -

TAG NO.	SEG. NO.	VOLTAGE (VOLTS)		CURRENT (AMPS)		IMPEDANCE (OHMS)		ADMITTANCE (MHOS)		POWER (WATTS)
		REAL	IMAG.	REAL	IMAG.	REAL	IMAG.	REAL	IMAG.	
0 *	5	1.00000E+00	0.00000E+00	9.38999E-03	-5.32896E-03	8.05525E+01	4.57148E+01	9.38999E-03	-5.32896E-03	4.69500E-03

- - - CURRENTS AND LOCATION - - -

LENGTHS NORMALIZED BY WAVELENGTH (OR 2.*PI/CABS(K))

SEG. NO.	TAG NO.	COORD. OF SEG. CENTER			SEG. LENGTH	CURRENT (AMPS)			PHASE
		X	Y	Z		REAL	IMAG.	MAG.	
1	0	0.0000	0.0000	-0.2189	0.06254	1.9607E-03	-1.2798E-03	2.3414E-03	-33.135
2	0	0.0000	0.0000	-0.1564	0.06254	5.3516E-03	-3.4033E-03	6.3421E-03	-32.454
3	0	0.0000	0.0000	-0.0938	0.06254	7.8677E-03	-4.8420E-03	9.2383E-03	-31.610
4	0	0.0000	0.0000	-0.0313	0.06254	9.2167E-03	-5.4146E-03	1.0690E-02	-30.433
5	0	0.0000	0.0000	0.0313	0.06254	9.2167E-03	-5.4146E-03	1.0690E-02	-30.433
6	0	0.0000	0.0000	0.0938	0.06254	7.8677E-03	-4.8420E-03	9.2383E-03	-31.610

7	0	0.0000	0.0000	0.1564	0.06254	5.3516E-03	-3.4033E-03	6.3421E-03	-32.454
8	0	0.0000	0.0000	0.2189	0.06254	1.9607E-03	-1.2798E-03	2.3414E-03	-33.135

- - - POWER BUDGET - - -

INPUT POWER = 4.6950E-03 WATTS
 RADIATED POWER= 4.6950E-03 WATTS
 WIRE LOSS = 0.0000E+00 WATTS
 EFFICIENCY = 100.00 PERCENT

- - - INPUT IMPEDANCE DATA - - -

SOURCE SEGMENT NO. 5
 NORMALIZATION FACTOR= 5.0000E+01

FREQ. MHZ	UNNORMALIZED IMPEDANCE				NORMALIZED IMPEDANCE				PHASE DEGREES
	RESISTANCE OHMS	REACTANCE OHMS	MAGNITUDE OHMS	PHASE DEGREES	RESISTANCE	REACTANCE	MAGNITUDE	PHASE DEGR	
200.000	2.65762E+01	-6.32060E+02	6.32619E+02	-87.59	5.31525E-01	-1.26412E+01	1.26524E+01	-87.	
250.000	4.71435E+01	-2.72372E+02	2.76422E+02	-80.18	9.42869E-01	-5.44744E+00	5.52843E+00	-80.	
300.000	8.05525E+01	4.57148E+01	9.26205E+01	29.58	1.61105E+00	9.14295E-01	1.85241E+00	29.	

***** INPUT LINE 4 LD 5 0 0 0 3.72000E+07 0.00000E+00 0.00000E+00 0.00000E+00 0.00000E+00 0.00000E+00
 ***** INPUT LINE 5 FR 0 1 0 0 3.00000E+02 0.00000E+00 0.00000E+00 0.00000E+00 0.00000E+00 0.00000E+00
 ***** INPUT LINE 6 EX 5 0 5 0 1.00000E+00 0.00000E+00 0.00000E+00 0.00000E+00 0.00000E+00 0.00000E+00
 ***** INPUT LINE 7 XQ 0 0 0 0 0.00000E+00 0.00000E+00 0.00000E+00 0.00000E+00 0.00000E+00 0.00000E+00

- - - - - FREQUENCY - - - - -

FREQUENCY= 3.0000E+02 MHZ
 WAVELENGTH= 9.9933E-01 METERS

- - - ANTENNA ENVIRONMENT - - -

FREE SPACE

- - - STRUCTURE IMPEDANCE LOADING - - -

LOCATION ITAG FROM THRU	RESISTANCE OHMS	INDUCTANCE HENRYS	CAPACITANCE FARADS	IMPEDANCE (OHMS)		CONDUCTIVITY MHOS/METER	TYPE
				REAL	IMAGINARY		
ALL						3.7200E+07	WIRE

- - - MATRIX TIMING - - -

FILL= 0.010 SEC., FACTOR= 0.000 SEC.

- - - ANTENNA INPUT PARAMETERS - - -

TAG NO.	SEG. NO.	VOLTAGE (VOLTS)		CURRENT (AMPS)		IMPEDANCE (OHMS)		ADMITTANCE (MHOS)		POWER (WATTS)	
		REAL	IMAG.	REAL	IMAG.	REAL	IMAG.	REAL	IMAG.		
0	*	5	1.00000E+00	0.00000E+00	6.64425E-03	-3.86653E-03	1.12431E+02	6.54279E+01	6.64425E-03	-3.86653E-03	3.32212E-03

- - - CURRENTS AND LOCATION - - -

LENGTHS NORMALIZED BY WAVELENGTH (OR 2.*PI/CABS(K))

SEG. NO.	TAG NO.	COORD. OF SEG. CENTER			SEG. LENGTH	CURRENT (AMPS)			PHASE
		X	Y	Z		REAL	IMAG.	MAG.	
1	0	0.0000	0.0000	-0.2189	0.06254	1.3862E-03	-9.6304E-04	1.6879E-03	-34.790
2	0	0.0000	0.0000	-0.1564	0.06254	3.7848E-03	-2.5546E-03	4.5662E-03	-34.018

3	0	0.0000	0.0000	-0.0938	0.06254	5.5658E-03	-3.6090E-03	6.6335E-03	-32.960
4	0	0.0000	0.0000	-0.0313	0.06254	6.5215E-03	-3.9782E-03	7.6391E-03	-31.384
5	0	0.0000	0.0000	0.0313	0.06254	6.5215E-03	-3.9782E-03	7.6391E-03	-31.384
6	0	0.0000	0.0000	0.0938	0.06254	5.5658E-03	-3.6090E-03	6.6335E-03	-32.960
7	0	0.0000	0.0000	0.1564	0.06254	3.7848E-03	-2.5546E-03	4.5662E-03	-34.018
8	0	0.0000	0.0000	0.2189	0.06254	1.3862E-03	-9.6304E-04	1.6879E-03	-34.790

- - - POWER BUDGET - - -

INPUT POWER = 3.3221E-03 WATTS
 RADIATED POWER = 2.4402E-03 WATTS
 WIRE LOSS = 8.8197E-04 WATTS
 EFFICIENCY = 73.45 PERCENT

***** INPUT LINE 8 NX 0 0 0 0 0.0000E+00 0.0000E+00 0.0000E+00 0.0000E+00 0.0000E+00 0.0000E+00

 *
 * NUMERICAL ELECTROMAGNETICS CODE (NEC-4.1) *
 *

 EXAMPLE 3. VERTICAL HALF WAVELENGTH ANTENNA OVER GROUND
 1. PERFECT GROUND
 2. IMPERFECT GROUND INCLUDING GROUND WAVE AND RECEIVING
 PATTERN CALCULATIONS

- - - STRUCTURE SPECIFICATION - - -

COORDINATES MUST BE INPUT IN
 METERS OR BE SCALED TO METERS
 BEFORE STRUCTURE INPUT IS ENDED

WIRE NO.	X1	Y1	Z1	X2	Y2	Z2	RADIUS	NO. OF SEG.	FIRST SEG.	LAST SEG.	TAG NO.
1	0.00000	0.00000	2.00000	0.00000	0.00000	7.00000	0.30000	9	1	9	0

GROUND PLANE SPECIFIED.

WHERE WIRE ENDS TOUCH GROUND, CURRENT WILL BE INTERPOLATED TO IMAGE IN GROUND PLANE.

TOTAL SEGMENTS USED= 9 NO. SEG. IN A SYMMETRIC CELL= 9 SYMMETRY FLAG= 0

- MULTIPLE WIRE JUNCTIONS -
 JUNCTION SEGMENTS (- FOR END 1, + FOR END 2)
 NONE

- - - - SEGMENTATION DATA - - - -

COORDINATES IN METERS

I+ AND I- INDICATE THE SEGMENTS BEFORE AND AFTER I

SEG. NO.	COORDINATES OF SEG.			CENTER	SEG. LENGTH	ORIENTATION ANGLES		WIRE RADIUS	CONNECTION DATA			TAG NO.
	X	Y	Z	Z		ALPHA	BETA		I-	I	I+	
1	0.00000	0.00000	2.27778	2.27778	0.55556	90.00000	0.00000	0.30000	0	1	2	0
2	0.00000	0.00000	2.83333	2.83333	0.55556	90.00000	0.00000	0.30000	1	2	3	0
3	0.00000	0.00000	3.38889	3.38889	0.55556	90.00000	0.00000	0.30000	2	3	4	0
4	0.00000	0.00000	3.94444	3.94444	0.55556	90.00000	0.00000	0.30000	3	4	5	0
5	0.00000	0.00000	4.50000	4.50000	0.55556	90.00000	0.00000	0.30000	4	5	6	0
6	0.00000	0.00000	5.05556	5.05556	0.55556	90.00000	0.00000	0.30000	5	6	7	0
7	0.00000	0.00000	5.61111	5.61111	0.55556	90.00000	0.00000	0.30000	6	7	8	0
8	0.00000	0.00000	6.16667	6.16667	0.55556	90.00000	0.00000	0.30000	7	8	9	0
9	0.00000	0.00000	6.72222	6.72222	0.55556	90.00000	0.00000	0.30000	8	9	0	0

*****	INPUT LINE	1	FR	0	1	0	0	3.00000E+01	0.00000E+00	0.00000E+00	0.00000E+00	0.00000E+00	0.00000E+00	0.00000E+00
*****	INPUT LINE	2	EX	0	0	5	0	1.00000E+00	0.00000E+00	0.00000E+00	0.00000E+00	0.00000E+00	0.00000E+00	0.00000E+00
*****	INPUT LINE	3	GN	1	0	0	0	0.00000E+00	0.00000E+00	0.00000E+00	0.00000E+00	0.00000E+00	0.00000E+00	0.00000E+00
*****	INPUT LINE	4	RP	0	10	2	1301	0.00000E+00	0.00000E+00	1.00000E+01	9.00000E+01	0.00000E+00	0.00000E+00	0.00000E+00

----- FREQUENCY -----

FREQUENCY= 3.0000E+01 MHZ
 WAVELENGTH= 9.9933E+00 METERS

----- ANTENNA ENVIRONMENT -----

PERFECT GROUND

----- STRUCTURE IMPEDANCE LOADING -----

THIS STRUCTURE IS NOT LOADED

----- MATRIX TIMING -----

FILL= 0.010 SEC., FACTOR= 0.000 SEC.

----- ANTENNA INPUT PARAMETERS -----

TAG NO.	SEG. NO.	VOLTAGE (VOLTS)		CURRENT (AMPS)		IMPEDANCE (OHMS)		ADMITTANCE (MHMS)		POWER (WATTS)
		REAL	IMAG.	REAL	IMAG.	REAL	IMAG.	REAL	IMAG.	
0	5	1.00000E+00	0.00000E+00	9.45362E-03	-2.45089E-05	1.05779E+02	2.74236E-01	9.45362E-03	-2.45089E-05	4.72681E-03

----- CURRENTS AND LOCATION -----

LENGTHS NORMALIZED BY WAVELENGTH (OR 2.*PI/CABS(K))

SEG. NO.	TAG NO.	COORD. OF SEG. CENTER			SEG. LENGTH	CURRENT (AMPS)			PHASE
		X	Y	Z		REAL	IMAG.	MAG.	
1	0	0.0000	0.0000	0.2279	0.05559	2.8919E-03	-2.5813E-03	3.8763E-03	-41.752
2	0	0.0000	0.0000	0.2835	0.05559	5.5642E-03	-4.1603E-03	6.9475E-03	-36.785
3	0	0.0000	0.0000	0.3391	0.05559	7.5810E-03	-4.6063E-03	8.8707E-03	-31.283
4	0	0.0000	0.0000	0.3947	0.05559	8.9151E-03	-4.0180E-03	9.7787E-03	-24.261
5	0	0.0000	0.0000	0.4503	0.05559	9.4536E-03	-2.4509E-05	9.4536E-03	-0.149
6	0	0.0000	0.0000	0.5059	0.05559	9.1337E-03	-4.0356E-03	9.9855E-03	-23.838
7	0	0.0000	0.0000	0.5615	0.05559	7.9642E-03	-4.6311E-03	9.2128E-03	-30.178
8	0	0.0000	0.0000	0.6171	0.05559	6.0055E-03	-4.1764E-03	7.3149E-03	-34.816
9	0	0.0000	0.0000	0.6727	0.05559	3.2249E-03	-2.5767E-03	4.1278E-03	-38.625

----- POWER BUDGET -----

INPUT POWER = 4.7268E-03 WATTS
 RADIATED POWER= 4.7268E-03 WATTS
 WIRE LOSS = 0.0000E+00 WATTS
 EFFICIENCY = 100.00 PERCENT

----- RADIATION PATTERNS -----

-- ANGLES --		- POWER GAINS -			- - - POLARIZATION - - -			- - - E(THETA) - - -		- - - E(PHI) - - -	
THETA DEGREES	PHI DEGREES	VERT. DB	HOR. DB	TOTAL DB	AXIAL RATIO	TILT DEG.	SENSE	MAGNITUDE VOLTS	PHASE DEGREES	MAGNITUDE VOLTS	PHASE DEGREES
0.00	0.00	-999.99	-999.99	-999.99	0.00000	0.00		0.00000E+00	0.00	0.00000E+00	0.00
10.00	0.00	-9.88	-999.99	-9.88	0.00000	0.00	LINEAR	1.70727E-01	-113.54	0.00000E+00	0.00
20.00	0.00	-4.21	-999.99	-4.21	0.00000	0.00	LINEAR	3.27688E-01	-113.81	0.00000E+00	0.00
30.00	0.00	-1.71	-999.99	-1.71	0.00000	0.00	LINEAR	4.37005E-01	-114.19	0.00000E+00	0.00
40.00	0.00	-1.76	-999.99	-1.76	0.00000	0.00	LINEAR	4.34909E-01	-114.57	0.00000E+00	0.00
50.00	0.00	-6.75	-999.99	-6.75	0.00000	0.00	LINEAR	2.44875E-01	-114.53	0.00000E+00	0.00
60.00	0.00	-10.06	-999.99	-10.06	0.00000	0.00	LINEAR	1.67177E-01	62.40	0.00000E+00	0.00
70.00	0.00	2.65	-999.99	2.65	0.00000	0.00	LINEAR	7.22664E-01	63.29	0.00000E+00	0.00
80.00	0.00	7.18	-999.99	7.18	0.00000	0.00	LINEAR	1.21715E+00	63.24	0.00000E+00	0.00
90.00	0.00	8.50	-999.99	8.50	0.00000	0.00	LINEAR	1.41677E+00	63.20	0.00000E+00	0.00
0.00	90.00	-999.99	-999.99	-999.99	0.00000	0.00		0.00000E+00	0.00	0.00000E+00	0.00
10.00	90.00	-9.88	-999.99	-9.88	0.00000	0.00	LINEAR	1.70727E-01	-113.54	0.00000E+00	0.00
20.00	90.00	-4.21	-999.99	-4.21	0.00000	0.00	LINEAR	3.27688E-01	-113.81	0.00000E+00	0.00
30.00	90.00	-1.71	-999.99	-1.71	0.00000	0.00	LINEAR	4.37005E-01	-114.19	0.00000E+00	0.00
40.00	90.00	-1.76	-999.99	-1.76	0.00000	0.00	LINEAR	4.34909E-01	-114.57	0.00000E+00	0.00

50.00	90.00	-6.75	-999.99	-6.75	0.00000	0.00	LINEAR	2.44875E-01	-114.53	0.00000E+00	0.00
60.00	90.00	-10.06	-999.99	-10.06	0.00000	0.00	LINEAR	1.67177E-01	62.40	0.00000E+00	0.00
70.00	90.00	2.65	-999.99	2.65	0.00000	0.00	LINEAR	7.22664E-01	63.29	0.00000E+00	0.00
80.00	90.00	7.18	-999.99	7.18	0.00000	0.00	LINEAR	1.21715E+00	63.24	0.00000E+00	0.00
90.00	90.00	8.50	-999.99	8.50	0.00000	0.00	LINEAR	1.41677E+00	63.20	0.00000E+00	0.00

AVERAGE POWER GAIN= 2.01877E+00 SOLID ANGLE USED IN AVERAGING=(0.5000)*PI STERADIANS.

POWER RADIATED ASSUMING RADIATION INTO 4*PI STERADIANS = 9.54232E-03 WATTS

--- NORMALIZED GAIN ---

VERTICAL GAIN
NORMALIZATION FACTOR = 8.50 DB

-- ANGLES --			-- ANGLES --			-- ANGLES --		
THETA	PHI	GAIN	THETA	PHI	GAIN	THETA	PHI	GAIN
DEGREES	DEGREES	DB	DEGREES	DEGREES	DB	DEGREES	DEGREES	DB
0.00	0.00	-1008.49	70.00	0.00	-5.85	40.00	90.00	-10.26
10.00	0.00	-18.38	80.00	0.00	-1.32	50.00	90.00	-15.25
20.00	0.00	-12.72	90.00	0.00	0.00	60.00	90.00	-18.56
30.00	0.00	-10.22	0.00	90.00	-1008.49	70.00	90.00	-5.85
40.00	0.00	-10.26	10.00	90.00	-18.38	80.00	90.00	-1.32
50.00	0.00	-15.25	20.00	90.00	-12.72	90.00	90.00	0.00
60.00	0.00	-18.56	30.00	90.00	-10.22			

***** INPUT LINE 5 GN 0 0 0 0 6.00000E+00 1.00000E-03 0.00000E+00 0.00000E+00 0.00000E+00 0.00000E+00
 ***** INPUT LINE 6 RP 0 10 2 1301 0.00000E+00 0.00000E+00 1.00000E+01 9.00000E+01 0.00000E+00 0.00000E+00

--- FREQUENCY ---

FREQUENCY= 3.0000E+01 MHZ
WAVELENGTH= 9.9933E+00 METERS

--- ANTENNA ENVIRONMENT ---

FINITE GROUND. REFLECTION COEFFICIENT APPROXIMATION
RELATIVE DIELECTRIC CONST.= 6.000
CONDUCTIVITY= 1.000E-03 MHOS/METER
COMPLEX DIELECTRIC CONSTANT= 6.00000E+00-5.99183E-01

--- STRUCTURE IMPEDANCE LOADING ---

THIS STRUCTURE IS NOT LOADED

--- MATRIX TIMING ---

FILL= 0.010 SEC., FACTOR= 0.000 SEC.

--- ANTENNA INPUT PARAMETERS ---

TAG NO.	SEG. NO.	VOLTAGE (VOLTS)		CURRENT (AMPS)		IMPEDANCE (OHMS)		ADMITTANCE (MHOS)		POWER (WATTS)
		REAL	IMAG.	REAL	IMAG.	REAL	IMAG.	REAL	IMAG.	
0	5	1.00000E+00	0.00000E+00	9.04517E-03	-5.37988E-05	1.10552E+02	6.57543E-01	9.04517E-03	-5.37988E-05	4.52258E-03

- - - CURRENTS AND LOCATION - - -

LENGTHS NORMALIZED BY WAVELENGTH (OR 2.*PI/CABS(K))

SEG. NO.	TAG NO.	COORD. OF SEG. CENTER			SEG. LENGTH	CURRENT (AMPS)			PHASE
		X	Y	Z		REAL	IMAG.	MAG.	
1	0	0.0000	0.0000	0.2279	0.05559	2.8751E-03	-2.5567E-03	3.8475E-03	-41.646
2	0	0.0000	0.0000	0.2835	0.05559	5.4615E-03	-4.1520E-03	6.8605E-03	-37.243
3	0	0.0000	0.0000	0.3391	0.05559	7.3684E-03	-4.6190E-03	8.6965E-03	-32.082
4	0	0.0000	0.0000	0.3947	0.05559	8.5928E-03	-4.0447E-03	9.4972E-03	-25.207
5	0	0.0000	0.0000	0.4503	0.05559	9.0452E-03	-5.3799E-05	9.0453E-03	-0.341
6	0	0.0000	0.0000	0.5059	0.05559	8.6815E-03	-4.0567E-03	9.5826E-03	-25.046
7	0	0.0000	0.0000	0.5615	0.05559	7.5241E-03	-4.6375E-03	8.8384E-03	-31.648
8	0	0.0000	0.0000	0.6171	0.05559	5.6410E-03	-4.1681E-03	7.0139E-03	-36.461
9	0	0.0000	0.0000	0.6727	0.05559	3.0109E-03	-2.5621E-03	3.9535E-03	-40.396

- - - POWER BUDGET - - -

INPUT POWER = 4.5226E-03 WATTS
 RADIATED POWER = 4.5226E-03 WATTS
 WIRE LOSS = 0.0000E+00 WATTS
 EFFICIENCY = 100.00 PERCENT

- - - RADIATION PATTERNS - - -

- - ANGLES - -		- POWER GAINS -			- - - POLARIZATION - - -			- - - E(THETA) - - -		- - - E(PHI) - - -	
THETA DEGREES	PHI DEGREES	VERT. DB	HOR. DB	TOTAL DB	AXIAL RATIO	TILT DEG.	SENSE	MAGNITUDE VOLTS	PHASE DEGREES	MAGNITUDE VOLTS	PHASE DEGREES
0.00	0.00	-999.99	-999.99	-999.99	0.00000	0.00		0.00000E+00	0.00	0.00000E+00	0.00
10.00	0.00	-12.88	-999.99	-12.88	0.00000	0.00	LINEAR	1.18226E-01	-123.90	0.00000E+00	0.00
20.00	0.00	-7.19	-999.99	-7.19	0.00000	0.00	LINEAR	2.27567E-01	-128.12	0.00000E+00	0.00
30.00	0.00	-4.48	-999.99	-4.48	0.00000	0.00	LINEAR	3.10746E-01	-136.54	0.00000E+00	0.00
40.00	0.00	-3.47	-999.99	-3.47	0.00000	0.00	LINEAR	3.49292E-01	-152.66	0.00000E+00	0.00
50.00	0.00	-2.96	-999.99	-2.96	0.00000	0.00	LINEAR	3.70491E-01	177.80	0.00000E+00	0.00
60.00	0.00	-0.81	-999.99	-0.81	0.00000	0.00	LINEAR	4.74477E-01	142.78	0.00000E+00	0.00
70.00	0.00	1.52	-999.99	1.52	0.00000	0.00	LINEAR	6.20232E-01	121.07	0.00000E+00	0.00
80.00	0.00	0.62	-999.99	0.62	0.00000	0.00	LINEAR	5.59348E-01	111.10	0.00000E+00	0.00
90.00	0.00	-999.99	-999.99	-999.99	0.00000	0.00		2.67585E-11	-72.33	0.00000E+00	0.00
0.00	90.00	-999.99	-999.99	-999.99	0.00000	0.00		0.00000E+00	0.00	0.00000E+00	0.00
10.00	90.00	-12.88	-999.99	-12.88	0.00000	0.00	LINEAR	1.18226E-01	-123.90	0.00000E+00	0.00
20.00	90.00	-7.19	-999.99	-7.19	0.00000	0.00	LINEAR	2.27567E-01	-128.12	0.00000E+00	0.00
30.00	90.00	-4.48	-999.99	-4.48	0.00000	0.00	LINEAR	3.10746E-01	-136.54	0.00000E+00	0.00
40.00	90.00	-3.47	-999.99	-3.47	0.00000	0.00	LINEAR	3.49292E-01	-152.66	0.00000E+00	0.00
50.00	90.00	-2.96	-999.99	-2.96	0.00000	0.00	LINEAR	3.70491E-01	177.80	0.00000E+00	0.00
60.00	90.00	-0.81	-999.99	-0.81	0.00000	0.00	LINEAR	4.74477E-01	142.78	0.00000E+00	0.00
70.00	90.00	1.52	-999.99	1.52	0.00000	0.00	LINEAR	6.20232E-01	121.07	0.00000E+00	0.00
80.00	90.00	0.62	-999.99	0.62	0.00000	0.00	LINEAR	5.59348E-01	111.10	0.00000E+00	0.00
90.00	90.00	-999.99	-999.99	-999.99	0.00000	0.00		2.67585E-11	-72.33	0.00000E+00	0.00

AVERAGE POWER GAIN = 7.17751E-01 SOLID ANGLE USED IN AVERAGING = (0.5000)*PI STERADIANS.

POWER RADIATED ASSUMING RADIATION INTO 4*PI STERADIANS = 3.24609E-03 WATTS

- - - - - NORMALIZED GAIN - - - - -

VERTICAL GAIN
 NORMALIZATION FACTOR = 1.52 DB

- - ANGLES - -		GAIN DB	- - ANGLES - -		GAIN DB	- - ANGLES - -		GAIN DB
THETA DEGREES	PHI DEGREES		THETA DEGREES	PHI DEGREES		THETA DEGREES	PHI DEGREES	
0.00	0.00	-1001.51	70.00	0.00	0.00	40.00	90.00	-4.99
10.00	0.00	-14.40	80.00	0.00	-0.90	50.00	90.00	-4.48
20.00	0.00	-8.71	90.00	0.00	-1001.51	60.00	90.00	-2.33
30.00	0.00	-6.00	0.00	90.00	-1001.51	70.00	90.00	0.00
40.00	0.00	-4.99	10.00	90.00	-14.40	80.00	90.00	-0.90
50.00	0.00	-4.48	20.00	90.00	-8.71	90.00	90.00	-1001.51
60.00	0.00	-2.33	30.00	90.00	-6.00			

***** INPUT LINE 7 RP 1 10 1 0 1.00000E+00 0.00000E+00 2.00000E+00 0.00000E+00 1.00000E+05 0.00000E+00

- - - RADIATED FIELDS NEAR GROUND - - -

- - - LOCATION - - -			- - E(THETA) - -		- - E(PHI) - -		- - E(RADIAL) - -	
RHO METERS	PHI DEGREES	Z METERS	MAG VOLTS/M	PHASE DEGREES	MAG VOLTS/M	PHASE DEGREES	MAG VOLTS/M	PHASE DEGREES
100000.00	0.00	1.00	2.2806E-09	147.04	0.0000E+00	0.00	8.3391E-10	-43.95
100000.00	0.00	3.00	2.6853E-09	169.58	0.0000E+00	0.00	8.3389E-10	-43.95
100000.00	0.00	5.00	3.3791E-09	-175.43	0.0000E+00	0.00	8.3384E-10	-43.95
100000.00	0.00	7.00	4.2218E-09	-165.96	0.0000E+00	0.00	8.3377E-10	-43.96
100000.00	0.00	9.00	5.1406E-09	-159.76	0.0000E+00	0.00	8.3369E-10	-43.96
100000.00	0.00	11.00	6.1012E-09	-155.48	0.0000E+00	0.00	8.3361E-10	-43.97
100000.00	0.00	13.00	7.0865E-09	-152.37	0.0000E+00	0.00	8.3352E-10	-43.97
100000.00	0.00	15.00	8.0874E-09	-150.04	0.0000E+00	0.00	8.3343E-10	-43.98
100000.00	0.00	17.00	9.0989E-09	-148.22	0.0000E+00	0.00	8.3333E-10	-43.99
100000.00	0.00	19.00	1.0118E-08	-146.77	0.0000E+00	0.00	8.3324E-10	-44.00

***** INPUT LINE 8 EX 1 10 1 0 0.00000E+00 0.00000E+00 0.00000E+00 1.00000E+01 0.00000E+00 0.00000E+00
 ***** INPUT LINE 9 PT 2 0 5 5 0.00000E+00 0.00000E+00 0.00000E+00 0.00000E+00 0.00000E+00 0.00000E+00
 ***** INPUT LINE 10 XQ 0 0 0 0 0.00000E+00 0.00000E+00 0.00000E+00 0.00000E+00 0.00000E+00 0.00000E+00

- - - RECEIVING PATTERN PARAMETERS - - -

ETA= 0.00 DEGREES
 TYPE -LINEAR
 AXIAL RATIO= 0.000

THETA (DEG)	PHI (DEG)	- CURRENT MAGNITUDE	- PHASE	SEG NO.
0.00	0.00	0.0000E+00	0.00	5
10.00	0.00	6.2726E-03	-33.91	5
20.00	0.00	1.2071E-02	-38.13	5
30.00	0.00	1.6476E-02	-46.55	5
40.00	0.00	1.8511E-02	-62.66	5
50.00	0.00	1.9625E-02	-92.20	5
60.00	0.00	2.5121E-02	-127.22	5
70.00	0.00	3.2827E-02	-148.93	5
80.00	0.00	2.9598E-02	-158.89	5
90.00	0.00	1.4158E-12	17.68	5

- - - NORMALIZED RECEIVING PATTERN - - -

NORMALIZATION FACTOR= 3.2827E-02
 ETA= 0.00 DEGREES
 TYPE -LINEAR
 AXIAL RATIO= 0.000
 SEGMENT NO.= 5

THETA (DEG)	PHI (DEG)	- PATTERN DB	- MAGNITUDE
0.00	0.00	-999.99	0.0000E+00
10.00	0.00	-14.38	1.9108E-01
20.00	0.00	-8.69	3.6771E-01
30.00	0.00	-5.99	5.0191E-01
40.00	0.00	-4.98	5.6390E-01
50.00	0.00	-4.47	5.9783E-01
60.00	0.00	-2.32	7.6527E-01
70.00	0.00	0.00	1.0000E+00
80.00	0.00	-0.90	9.0163E-01
90.00	0.00	-207.30	4.3129E-11

***** INPUT LINE 11 NX 0 0 0 0 0.00000E+00 0.00000E+00 0.00000E+00 0.00000E+00 0.00000E+00 0.00000E+00

 *
 * NUMERICAL ELECTROMAGNETICS CODE (NEC-4.1) *
 *

 EXAMPLE 4. T ANTENNA ON A BOX OVER PERFECT GROUND

- - - STRUCTURE SPECIFICATION - - -

COORDINATES MUST BE INPUT IN METERS OR BE SCALED TO METERS BEFORE STRUCTURE INPUT IS ENDED

WIRE NO.	X1	Y1	Z1	X2	Y2	Z2	RADIUS	NO. OF SEG.	FIRST SEG.	LAST SEG.	TAG NO.
1P	0.10000	0.05000	0.05000	0.00000	0.00000	0.01000					
2P	0.05000	0.10000	0.05000	0.00000	90.00000	0.01000					
STRUCTURE REFLECTED ALONG THE AXES X Y . TAGS INCREMENTED BY 0											
9P	0.00000	0.00000	0.10000	90.00000	0.00000	0.04000					
1	0.00000	0.00000	0.10000	0.00000	0.00000	0.30000	0.00100	4	1	4	1
2	0.00000	0.00000	0.30000	0.15000	0.00000	0.30000	0.00100	2	5	6	2
3	0.00000	0.00000	0.30000	-0.15000	0.00000	0.30000	0.00100	2	7	8	3

GROUND PLANE SPECIFIED.

WHERE WIRE ENDS TOUCH GROUND, CURRENT WILL BE INTERPOLATED TO IMAGE IN GROUND PLANE.

TOTAL SEGMENTS USED= 8 NO. SEG. IN A SYMMETRIC CELL= 8 SYMMETRY FLAG= 0
 TOTAL PATCHES USED= 12 NO. PATCHES IN A SYMMETRIC CELL= 12

- MULTIPLE WIRE JUNCTIONS -

JUNCTION	SEGMENTS (- FOR END 1, + FOR END 2)
1	4 -5 -7

- - - - SEGMENTATION DATA - - - -

COORDINATES IN METERS

I+ AND I- INDICATE THE SEGMENTS BEFORE AND AFTER I

SEG. NO.	COORDINATES OF SEG. CENTER			SEG. LENGTH	ORIENTATION ANGLES		WIRE RADIUS	CONNECTION DATA			TAG NO.
	X	Y	Z		ALPHA	BETA		I-	I	I+	
1	0.00000	0.00000	0.12500	0.05000	90.00000	0.00000	0.00100	10009	1	2	1
2	0.00000	0.00000	0.17500	0.05000	90.00000	0.00000	0.00100		1	2	3
3	0.00000	0.00000	0.22500	0.05000	90.00000	0.00000	0.00100		2	3	4
4	0.00000	0.00000	0.27500	0.05000	90.00000	0.00000	0.00100		3	4	5
5	0.03750	0.00000	0.30000	0.07500	0.00000	0.00000	0.00100		-7	5	6
6	0.11250	0.00000	0.30000	0.07500	0.00000	0.00000	0.00100		5	6	0
7	-0.03750	0.00000	0.30000	0.07500	0.00000	180.00000	0.00100		4	7	8
8	-0.11250	0.00000	0.30000	0.07500	0.00000	180.00000	0.00100		7	8	0

- - - SURFACE PATCH DATA - - -

COORDINATES IN METERS

PATCH NO.	COORD. OF PATCH CENTER			UNIT NORMAL VECTOR			PATCH AREA	COMPONENTS OF UNIT TANGENT VECTORS						
	X	Y	Z	X	Y	Z		X1	Y1	Z1	X2	Y2	Z2	
1	0.10000	0.05000	0.05000	1.0000	0.0000	0.0000	0.01000	0.0000	1.0000	0.0000	0.0000	0.0000	0.0000	1.0000
2	0.05000	0.10000	0.05000	0.0000	1.0000	0.0000	0.01000	-1.0000	0.0000	0.0000	0.0000	0.0000	0.0000	1.0000
3	0.10000	-0.05000	0.05000	1.0000	0.0000	0.0000	0.01000	0.0000	-1.0000	0.0000	0.0000	0.0000	0.0000	1.0000

4	0.05000	-0.10000	0.05000	0.0000	-1.0000	0.0000	0.01000	-1.0000	0.0000	0.0000	0.0000	0.0000	0.0000	1.0000
5	-0.10000	0.05000	0.05000	-1.0000	0.0000	0.0000	0.01000	0.0000	1.0000	0.0000	0.0000	0.0000	0.0000	1.0000
6	-0.05000	0.10000	0.05000	0.0000	1.0000	0.0000	0.01000	1.0000	0.0000	0.0000	0.0000	0.0000	0.0000	1.0000
7	-0.10000	-0.05000	0.05000	-1.0000	0.0000	0.0000	0.01000	0.0000	-1.0000	0.0000	0.0000	0.0000	0.0000	1.0000
8	-0.05000	-0.10000	0.05000	0.0000	-1.0000	0.0000	0.01000	1.0000	0.0000	0.0000	0.0000	0.0000	0.0000	1.0000
9	0.05000	0.05000	0.10000	0.0000	0.0000	1.0000	0.01000	1.0000	0.0000	0.0000	0.0000	0.0000	1.0000	0.0000
10	-0.05000	0.05000	0.10000	0.0000	0.0000	1.0000	0.01000	1.0000	0.0000	0.0000	0.0000	0.0000	1.0000	0.0000
11	-0.05000	-0.05000	0.10000	0.0000	0.0000	1.0000	0.01000	1.0000	0.0000	0.0000	0.0000	0.0000	1.0000	0.0000
12	0.05000	-0.05000	0.10000	0.0000	0.0000	1.0000	0.01000	1.0000	0.0000	0.0000	0.0000	0.0000	1.0000	0.0000

```

***** INPUT LINE 1 GN 1 0 0 0 0.00000E+00 0.00000E+00 0.00000E+00 0.00000E+00 0.00000E+00 0.00000E+00
***** INPUT LINE 2 EX 0 1 1 0 1.00000E+00 0.00000E+00 0.00000E+00 0.00000E+00 0.00000E+00 0.00000E+00
***** INPUT LINE 3 RP 0 10 4 1001 0.00000E+00 0.00000E+00 1.00000E+01 3.00000E+01 0.00000E+00 0.00000E+00

```

----- FREQUENCY -----

FREQUENCY= 2.9980E+02 MHZ
WAVELENGTH= 1.0000E+00 METERS

--- ANTENNA ENVIRONMENT ---

PERFECT GROUND

--- STRUCTURE IMPEDANCE LOADING ---

THIS STRUCTURE IS NOT LOADED

--- MATRIX TIMING ---

FILL= 0.040 SEC., FACTOR= 0.000 SEC.

--- ANTENNA INPUT PARAMETERS ---

TAG NO.	SEG. NO.	VOLTAGE (VOLTS)		CURRENT (AMPS)		IMPEDANCE (OHMS)		ADMITTANCE (MHOS)		POWER (WATTS)
		REAL	IMAG.	REAL	IMAG.	REAL	IMAG.	REAL	IMAG.	
1	1	1.00000E+00	0.00000E+00	2.17993E-03	-2.66254E-03	1.84097E+02	2.24853E+02	2.17993E-03	-2.66254E-03	1.08997E-03

--- CURRENTS AND LOCATION ---

LENGTHS NORMALIZED BY WAVELENGTH (OR 2.*PI/CABS(K))

SEG. NO.	TAG NO.	COORD. OF SEG. CENTER			SEG. LENGTH	CURRENT (AMPS)			PHASE
		X	Y	Z		REAL	IMAG.	MAG.	
1	1	0.0000	0.0000	0.1250	0.05000	2.1799E-03	-2.6625E-03	3.4411E-03	-50.691
2	1	0.0000	0.0000	0.1750	0.05000	2.1579E-03	-3.4413E-03	4.0619E-03	-57.911
3	1	0.0000	0.0000	0.2250	0.05000	2.0988E-03	-3.8734E-03	4.4055E-03	-61.549
4	1	0.0000	0.0000	0.2750	0.05000	1.9793E-03	-3.8860E-03	4.3611E-03	-63.008
5	2	0.0375	0.0000	0.3000	0.07500	7.9588E-04	-1.5851E-03	1.7737E-03	-63.339
6	2	0.1125	0.0000	0.3000	0.07500	3.1430E-04	-6.4730E-04	7.1957E-04	-64.101
7	3	-0.0375	0.0000	0.3000	0.07500	7.9588E-04	-1.5851E-03	1.7737E-03	-63.339
8	3	-0.1125	0.0000	0.3000	0.07500	3.1430E-04	-6.4730E-04	7.1957E-04	-64.101

--- SURFACE PATCH CURRENTS ---

DISTANCES IN WAVELENGTHS (2.*PI/CABS(K))
CURRENT IN AMPS/METER

PATCH NO.	PATCH CENTER			SURFACE COMPONENTS				RECTANGULAR COMPONENTS					
	X	Y	Z	TANGENT VECTOR 1 MAG.	PHASE	TANGENT VECTOR 2 MAG.	PHASE	REAL	IMAG.	REAL	IMAG.	REAL	IMAG.
1	0.100	0.050	0.050	1.1832E-03	111.34	8.2597E-03	-116.30	0.00E+00	0.00E+00	-4.30E-04	1.10E-03	-3.66E-03	-7.40E-03

2	0.050	0.100	0.050	1.1755E-03	-68.82	8.0984E-03	-117.13	-4.25E-04	1.10E-03	-2.17E-15	5.59E-15	-3.69E-03	-7.21E-03
3	0.100	-0.050	0.050	1.1832E-03	111.34	8.2597E-03	-116.30	0.00E+00	0.00E+00	4.30E-04	-1.10E-03	-3.66E-03	-7.40E-03
4	0.050	-0.100	0.050	1.1755E-03	-68.82	8.0984E-03	-117.13	-4.25E-04	1.10E-03	2.17E-15	-5.59E-15	-3.69E-03	-7.21E-03
5	-0.100	0.050	0.050	1.1832E-03	111.34	8.2597E-03	-116.30	0.00E+00	0.00E+00	-4.30E-04	1.10E-03	-3.66E-03	-7.40E-03
6	-0.050	0.100	0.050	1.1755E-03	-68.82	8.0984E-03	-117.13	4.25E-04	-1.10E-03	-2.17E-15	5.59E-15	-3.69E-03	-7.21E-03
7	-0.100	-0.050	0.050	1.1832E-03	111.34	8.2597E-03	-116.30	0.00E+00	0.00E+00	4.30E-04	-1.10E-03	-3.66E-03	-7.40E-03
8	-0.050	-0.100	0.050	1.1755E-03	-68.82	8.0984E-03	-117.13	4.25E-04	-1.10E-03	2.17E-15	-5.59E-15	-3.69E-03	-7.21E-03
9	0.050	0.050	0.100	6.8284E-03	111.24	6.6278E-03	111.27	-2.47E-03	6.36E-03	-2.40E-03	6.18E-03	0.00E+00	0.00E+00
10	-0.050	0.050	0.100	6.8284E-03	-68.76	6.6278E-03	111.27	2.47E-03	-6.36E-03	-2.40E-03	6.18E-03	0.00E+00	0.00E+00
11	-0.050	-0.050	0.100	6.8284E-03	-68.76	6.6278E-03	-68.73	2.47E-03	-6.36E-03	2.40E-03	-6.18E-03	0.00E+00	0.00E+00
12	0.050	-0.050	0.100	6.8284E-03	111.24	6.6278E-03	-68.73	-2.47E-03	6.36E-03	2.40E-03	-6.18E-03	0.00E+00	0.00E+00

- - - POWER BUDGET - - -

INPUT POWER = 1.0900E-03 WATTS
 RADIATED POWER = 1.0900E-03 WATTS
 WIRE LOSS = 0.0000E+00 WATTS
 EFFICIENCY = 100.00 PERCENT

- - - RADIATION PATTERNS - - -

- - ANGLES - -		- POWER GAINS -			- - - POLARIZATION - - -			- - - E(THETA) - - -		- - - E(PHI) - - -	
THETA	PHI	VERT.	HOR.	TOTAL	AXIAL	TILT	SENSE	MAGNITUDE	PHASE	MAGNITUDE	PHASE
DEGREES	DEGREES	DB	DB	DB	RATIO	DEG.		VOLTS	DEGREES	VOLTS	DEGREES
0.00	0.00	-999.99	-999.99	-999.99	0.00000	0.00		2.89382E-17	-48.58	1.17679E-17	-102.53
10.00	0.00	-13.76	-999.99	-13.76	0.00000	0.00	LINEAR	5.24152E-02	-8.09	6.38205E-18	-90.00
20.00	0.00	-7.53	-999.99	-7.53	0.00000	0.00	LINEAR	1.07389E-01	-6.16	1.11458E-17	-76.76
30.00	0.00	-3.71	-999.99	-3.71	0.00000	0.00	LINEAR	1.66732E-01	-3.44	1.25874E-17	-120.47
40.00	0.00	-0.90	-999.99	-0.90	0.00000	0.00	LINEAR	2.30546E-01	-0.47	8.17302E-18	-128.66
50.00	0.00	1.28	-999.99	1.28	0.00000	0.00	LINEAR	2.96354E-01	2.31	4.34027E-18	-126.03
60.00	0.00	2.95	-999.99	2.95	0.00000	0.00	LINEAR	3.58947E-01	4.60	6.38205E-18	-143.13
70.00	0.00	4.13	-999.99	4.13	0.00000	0.00	LINEAR	4.11285E-01	6.28	3.82923E-18	-90.00
80.00	0.00	4.84	-999.99	4.84	0.00000	0.00	LINEAR	4.46239E-01	7.29	3.61024E-18	-135.00
90.00	0.00	5.07	-999.99	5.07	0.00000	0.00	LINEAR	4.58537E-01	7.63	1.27641E-18	180.00
0.00	30.00	-999.99	-999.99	-999.99	0.00000	0.00		2.89177E-17	-58.05	1.18183E-17	175.63
10.00	30.00	-14.02	-37.74	-14.00	0.03788	-3.04	RIGHT	5.08749E-02	-9.29	3.31671E-03	-153.65
20.00	30.00	-7.78	-31.70	-7.76	0.03512	-3.04	RIGHT	1.04393E-01	-7.22	6.65069E-03	-153.65
30.00	30.00	-3.93	-28.28	-3.92	0.03081	-2.99	RIGHT	1.62562E-01	-4.29	9.85483E-03	-153.65
40.00	30.00	-1.08	-26.20	-1.07	0.02548	-2.82	RIGHT	2.25791E-01	-1.09	1.25178E-02	-153.65
50.00	30.00	1.15	-25.23	1.16	0.01980	-2.50	RIGHT	2.91871E-01	1.90	1.39927E-02	-153.65
60.00	30.00	2.87	-25.49	2.87	0.01428	-2.03	RIGHT	3.55596E-01	4.37	9.85483E-03	-153.65
70.00	30.00	4.09	-27.40	4.10	0.00918	-1.43	RIGHT	4.09539E-01	6.17	1.09041E-02	-153.65
80.00	30.00	4.83	-32.45	4.83	0.00447	-0.74	RIGHT	4.45896E-01	7.26	6.09516E-03	-153.65
90.00	30.00	5.08	-999.99	5.08	0.00000	0.00	LINEAR	4.58750E-01	7.62	1.84999E-13	26.35
0.00	60.00	-999.99	-999.99	-999.99	0.00000	0.00		2.20628E-17	-70.51	2.21165E-17	143.85
10.00	60.00	-14.55	-37.73	-14.53	0.04285	-3.12	RIGHT	4.78614E-02	-11.92	3.32118E-03	-153.65
20.00	60.00	-8.29	-31.65	-8.27	0.03966	-3.15	RIGHT	9.84705E-02	-9.54	6.68451E-03	-153.66
30.00	60.00	-4.39	-28.19	-4.37	0.03457	-3.12	RIGHT	1.54197E-01	-6.15	9.95790E-03	-153.68
40.00	60.00	-1.46	-26.06	-1.44	0.02825	-2.96	RIGHT	2.16095E-01	-2.44	1.27252E-02	-153.69
50.00	60.00	0.87	-25.04	0.88	0.02157	-2.62	RIGHT	2.82571E-01	1.04	1.43094E-02	-153.70
60.00	60.00	2.69	-25.25	2.70	0.01526	-2.12	RIGHT	3.48500E-01	3.90	1.39723E-02	-153.71
70.00	60.00	4.01	-27.13	4.01	0.00963	-1.49	RIGHT	4.05698E-01	5.97	1.12550E-02	-153.71
80.00	60.00	4.81	-32.16	4.81	0.00463	-0.77	RIGHT	4.44953E-01	7.21	6.30753E-03	-153.71
90.00	60.00	5.08	-999.99	5.08	0.00000	0.00	LINEAR	4.58964E-01	7.62	1.91604E-13	26.29
0.00	90.00	-999.99	-999.99	-999.99	0.00000	0.00		1.17679E-17	-102.53	2.89382E-17	131.42
10.00	90.00	-14.82	-999.99	-14.82	0.00000	0.00	LINEAR	4.63930E-02	-13.37	3.91661E-14	26.37
20.00	90.00	-8.55	-999.99	-8.55	0.00000	0.00	LINEAR	9.55519E-02	-10.81	7.89782E-14	26.34
30.00	90.00	-4.63	-999.99	-4.63	0.00000	0.00	LINEAR	1.50010E-01	-7.17	1.17989E-13	26.32
40.00	90.00	-1.66	-999.99	-1.66	0.00000	0.00	LINEAR	2.11160E-01	-3.17	1.51222E-13	26.30
50.00	90.00	0.72	-999.99	0.72	0.00000	0.00	LINEAR	2.77755E-01	0.57	1.70515E-13	26.29
60.00	90.00	2.60	-999.99	2.60	0.00000	0.00	LINEAR	3.44753E-01	3.64	1.66907E-13	26.28
70.00	90.00	3.97	-999.99	3.97	0.00000	0.00	LINEAR	4.03603E-01	5.87	1.34729E-13	26.26
80.00	90.00	4.80	-999.99	4.80	0.00000	0.00	LINEAR	4.44352E-01	7.19	7.55953E-14	26.26
90.00	90.00	5.08	-999.99	5.08	0.00000	0.00	LINEAR	4.58965E-01	7.63	6.38205E-19	90.00

AVERAGE POWER GAIN= 1.80188E+00 SOLID ANGLE USED IN AVERAGING=(0.5000)*PI STERADIANS.
POWER RADIATED ASSUMING RADIATION INTO 4*PI STERADIANS = 1.96399E-03 WATTS

***** INPUT LINE 4 EN 0 0 0 0 0.00000E+00 0.00000E+00 0.00000E+00 0.00000E+00 0.00000E+00 0.00000E+00
RUN TIME = 0.500

4.2.2 Example 5, Log-Periodic Antenna

Example 5 is a practical log-periodic antenna with 12 elements. Input data for the transmission line sections is printed in the table "NETWORK DATA." The table "STRUCTURE EXCITATION DATA AT NETWORK CONNECTION POINTS" contains the voltage, current, impedance, admittance and power at each segment to which the transmission lines or networks connect. The currents printed in this table are the currents in the segments at the connection points, and will differ from the current into the connected transmission line if there are other transmission lines, network ports or a voltage source providing alternate current paths. Thus, the current printed for segment 3 differs from that in the table "INPUT PARAMETERS." The latter is the current through the voltage source and includes the current into the segment and into the transmission line. Power listed in the network-connection table is the power being fed into the segment. A negative power indicates that the structure is feeding power into the network or transmission line.

This example was run with the parameter MAXMAT set to 64 to illustrate the output format when file storage must be used for the matrix. The line after the listing of input line 14 shows how the matrix has been divided into blocks for transfer between memory and file storage. The line "CP TIME TAKEN FOR FACTORIZATION" shows the amount of central processor time used to factor the matrix, excluding I/O time. This will be less than the total factoring time printed below in the output.

Input for Example 5

```

CM 12 ELEMENT LOG PERIODIC ANTENNA IN FREE SPACE.
CM 78 SEGMENTS. SIGMA=D/L RECEIVING AND TRANS. PATTERNS.
CM DIPOLE LENGTH TO DIAMETER RATIO=150.
CE TAU=0.93, SIGMA=0.70, BOOM IMPEDANCE=50. OHMS.
GW 1 5 0. -1. 0. 0. 1. 0. 0.00667
GW 2 5 -.7527 -1.0753 0. -.7527 1.0753 0. .00717
GW 3 5 -1.562 -1.1562 0. -1.562 1.1562 0. .00771
GW 4 5 -2.4323 -1.2432 0. -2.4323 1.2432 0. .00829
GW 5 5 -3.368 -1.3368 0. -3.368 1.3368 0. .00891
GW 6 7 -4.3742 -1.4374 0. -4.3742 1.4374 0. .00958
GW 7 7 -5.4562 -1.5456 0. -5.4562 1.5456 0. .0103
GW 8 7 -6.6195 -1.6619 0. -6.6195 1.6619 0. .01108
GW 9 7 -7.8705 -1.787 0. -7.8705 1.787 0. .01191
GW 10 7 -9.2156 -1.9215 0. -9.2156 1.9215 0. .01281
GW 11 9 -10.6619 -2.0662 0. -10.6619 2.0662 0. .01377
GW 12 9 -12.2171 -2.2217 0. -12.2171 2.2217 0. .01481
GE
FR 0 0 0 0 46.29
TL 1 3 2 3 -50.
TL 2 3 3 3 -50.
TL 3 3 4 3 -50.
TL 4 3 5 3 -50.
TL 5 3 6 4 -50.
TL 6 4 7 4 -50.
TL 7 4 8 4 -50.
TL 8 4 9 4 -50.
TL 9 4 10 4 -50.
TL 10 4 11 5 -50.
TL 11 5 12 5 -50. 0. 0. 0. .02
EX 0 1 3 10 1.
RP 0 37 1 1110 90. 0. -5. 0.
EN

```

Output for Example 5

```

*****
*
* NUMERICAL ELECTROMAGNETICS CODE (NEC-4.1) *
*
*****
    
```

```

*****
12 ELEMENT LOG PERIODIC ANTENNA IN FREE SPACE.
78 SEGMENTS. SIGMA=D/L RECEIVING AND TRANS. PATTERNS.
DIPOLE LENGTH TO DIAMETER RATIO=150.
TAU=0.93, SIGMA=0.70, BOOM IMPEDANCE=50. OHMS.
*****
    
```

- - - STRUCTURE SPECIFICATION - - -

COORDINATES MUST BE INPUT IN
METERS OR BE SCALED TO METERS
BEFORE STRUCTURE INPUT IS ENDED

WIRE NO.	X1	Y1	Z1	X2	Y2	Z2	RADIUS	NO. OF SEG.	FIRST SEG.	LAST SEG.	TAG NO.
1	0.00000	-1.00000	0.00000	0.00000	1.00000	0.00000	0.00667	5	1	5	1
2	-0.75270	-1.07530	0.00000	-0.75270	1.07530	0.00000	0.00717	5	6	10	2
3	-1.56200	-1.15620	0.00000	-1.56200	1.15620	0.00000	0.00771	5	11	15	3
4	-2.43230	-1.24320	0.00000	-2.43230	1.24320	0.00000	0.00829	5	16	20	4
5	-3.36800	-1.33680	0.00000	-3.36800	1.33680	0.00000	0.00891	5	21	25	5
6	-4.37420	-1.43740	0.00000	-4.37420	1.43740	0.00000	0.00958	7	26	32	6
7	-5.45620	-1.54560	0.00000	-5.45620	1.54560	0.00000	0.01030	7	33	39	7
8	-6.61950	-1.66190	0.00000	-6.61950	1.66190	0.00000	0.01108	7	40	46	8
9	-7.87050	-1.78700	0.00000	-7.87050	1.78700	0.00000	0.01191	7	47	53	9
10	-9.21560	-1.92150	0.00000	-9.21560	1.92150	0.00000	0.01281	7	54	60	10
11	-10.66190	-2.06620	0.00000	-10.66190	2.06620	0.00000	0.01377	9	61	69	11
12	-12.21710	-2.22170	0.00000	-12.21710	2.22170	0.00000	0.01481	9	70	78	12

TOTAL SEGMENTS USED= 78 NO. SEG. IN A SYMMETRIC CELL= 78 SYMMETRY FLAG= 0

- MULTIPLE WIRE JUNCTIONS -
JUNCTION SEGMENTS (- FOR END 1, + FOR END 2)
NONE

- - - - SEGMENTATION DATA - - - -

COORDINATES IN METERS

I+ AND I- INDICATE THE SEGMENTS BEFORE AND AFTER I

SEG. NO.	COORDINATES OF SEG. CENTER			SEG. LENGTH	ORIENTATION ANGLES		WIRE RADIUS	CONNECTION DATA			TAG NO.
	X	Y	Z		ALPHA	BETA		I-	I	I+	
1	0.00000	-0.80000	0.00000	0.40000	0.00000	90.00000	0.00667	0	1	2	1
2	0.00000	-0.40000	0.00000	0.40000	0.00000	90.00000	0.00667	1	2	3	1
3	0.00000	0.00000	0.00000	0.40000	0.00000	90.00000	0.00667	2	3	4	1
4	0.00000	0.40000	0.00000	0.40000	0.00000	90.00000	0.00667	3	4	5	1
5	0.00000	0.80000	0.00000	0.40000	0.00000	90.00000	0.00667	4	5	0	1
6	-0.75270	-0.86024	0.00000	0.43012	0.00000	90.00000	0.00717	0	6	7	2
7	-0.75270	-0.43012	0.00000	0.43012	0.00000	90.00000	0.00717	6	7	8	2
8	-0.75270	0.00000	0.00000	0.43012	0.00000	90.00000	0.00717	7	8	9	2
9	-0.75270	0.43012	0.00000	0.43012	0.00000	90.00000	0.00717	8	9	10	2
10	-0.75270	0.86024	0.00000	0.43012	0.00000	90.00000	0.00717	9	10	0	2

11	-1.56200	-0.92496	0.00000	0.46248	0.00000	90.00000	0.00771	0	11	12	3
12	-1.56200	-0.46248	0.00000	0.46248	0.00000	90.00000	0.00771	11	12	13	3
13	-1.56200	0.00000	0.00000	0.46248	0.00000	90.00000	0.00771	12	13	14	3
14	-1.56200	0.46248	0.00000	0.46248	0.00000	90.00000	0.00771	13	14	15	3
15	-1.56200	0.92496	0.00000	0.46248	0.00000	90.00000	0.00771	14	15	0	3
16	-2.43230	-0.99456	0.00000	0.49728	0.00000	90.00000	0.00829	0	16	17	4
17	-2.43230	-0.49728	0.00000	0.49728	0.00000	90.00000	0.00829	16	17	18	4
18	-2.43230	0.00000	0.00000	0.49728	0.00000	90.00000	0.00829	17	18	19	4
19	-2.43230	0.49728	0.00000	0.49728	0.00000	90.00000	0.00829	18	19	20	4
20	-2.43230	0.99456	0.00000	0.49728	0.00000	90.00000	0.00829	19	20	0	4
21	-3.36800	-1.06944	0.00000	0.53472	0.00000	90.00000	0.00891	0	21	22	5
22	-3.36800	-0.53472	0.00000	0.53472	0.00000	90.00000	0.00891	21	22	23	5
23	-3.36800	0.00000	0.00000	0.53472	0.00000	90.00000	0.00891	22	23	24	5
24	-3.36800	0.53472	0.00000	0.53472	0.00000	90.00000	0.00891	23	24	25	5
25	-3.36800	1.06944	0.00000	0.53472	0.00000	90.00000	0.00891	24	25	0	5
26	-4.37420	-1.23206	0.00000	0.41069	0.00000	90.00000	0.00958	0	26	27	6
27	-4.37420	-0.82137	0.00000	0.41069	0.00000	90.00000	0.00958	26	27	28	6
28	-4.37420	-0.41069	0.00000	0.41069	0.00000	90.00000	0.00958	27	28	29	6
29	-4.37420	0.00000	0.00000	0.41069	0.00000	90.00000	0.00958	28	29	30	6
30	-4.37420	0.41069	0.00000	0.41069	0.00000	90.00000	0.00958	29	30	31	6
31	-4.37420	0.82137	0.00000	0.41069	0.00000	90.00000	0.00958	30	31	32	6
32	-4.37420	1.23206	0.00000	0.41069	0.00000	90.00000	0.00958	31	32	0	6
33	-5.45620	-1.32480	0.00000	0.44160	0.00000	90.00000	0.01030	0	33	34	7
34	-5.45620	-0.88320	0.00000	0.44160	0.00000	90.00000	0.01030	33	34	35	7
35	-5.45620	-0.44160	0.00000	0.44160	0.00000	90.00000	0.01030	34	35	36	7
36	-5.45620	0.00000	0.00000	0.44160	0.00000	90.00000	0.01030	35	36	37	7
37	-5.45620	0.44160	0.00000	0.44160	0.00000	90.00000	0.01030	36	37	38	7
38	-5.45620	0.88320	0.00000	0.44160	0.00000	90.00000	0.01030	37	38	39	7
39	-5.45620	1.32480	0.00000	0.44160	0.00000	90.00000	0.01030	38	39	0	7
40	-6.61950	-1.42449	0.00000	0.47483	0.00000	90.00000	0.01108	0	40	41	8
41	-6.61950	-0.94966	0.00000	0.47483	0.00000	90.00000	0.01108	40	41	42	8
42	-6.61950	-0.47483	0.00000	0.47483	0.00000	90.00000	0.01108	41	42	43	8
43	-6.61950	0.00000	0.00000	0.47483	0.00000	90.00000	0.01108	42	43	44	8
44	-6.61950	0.47483	0.00000	0.47483	0.00000	90.00000	0.01108	43	44	45	8
45	-6.61950	0.94966	0.00000	0.47483	0.00000	90.00000	0.01108	44	45	46	8
46	-6.61950	1.42449	0.00000	0.47483	0.00000	90.00000	0.01108	45	46	0	8
47	-7.87050	-1.53171	0.00000	0.51057	0.00000	90.00000	0.01191	0	47	48	9
48	-7.87050	-1.02114	0.00000	0.51057	0.00000	90.00000	0.01191	47	48	49	9
49	-7.87050	-0.51057	0.00000	0.51057	0.00000	90.00000	0.01191	48	49	50	9
50	-7.87050	0.00000	0.00000	0.51057	0.00000	90.00000	0.01191	49	50	51	9
51	-7.87050	0.51057	0.00000	0.51057	0.00000	90.00000	0.01191	50	51	52	9
52	-7.87050	1.02114	0.00000	0.51057	0.00000	90.00000	0.01191	51	52	53	9
53	-7.87050	1.53171	0.00000	0.51057	0.00000	90.00000	0.01191	52	53	0	9
54	-9.21560	-1.64700	0.00000	0.54900	0.00000	90.00000	0.01281	0	54	55	10
55	-9.21560	-1.09800	0.00000	0.54900	0.00000	90.00000	0.01281	54	55	56	10
56	-9.21560	-0.54900	0.00000	0.54900	0.00000	90.00000	0.01281	55	56	57	10
57	-9.21560	0.00000	0.00000	0.54900	0.00000	90.00000	0.01281	56	57	58	10
58	-9.21560	0.54900	0.00000	0.54900	0.00000	90.00000	0.01281	57	58	59	10
59	-9.21560	1.09800	0.00000	0.54900	0.00000	90.00000	0.01281	58	59	60	10
60	-9.21560	1.64700	0.00000	0.54900	0.00000	90.00000	0.01281	59	60	0	10
61	-10.66190	-1.83662	0.00000	0.45916	0.00000	90.00000	0.01377	0	61	62	11
62	-10.66190	-1.37747	0.00000	0.45916	0.00000	90.00000	0.01377	61	62	63	11
63	-10.66190	-0.91831	0.00000	0.45916	0.00000	90.00000	0.01377	62	63	64	11
64	-10.66190	-0.45916	0.00000	0.45916	0.00000	90.00000	0.01377	63	64	65	11
65	-10.66190	0.00000	0.00000	0.45916	0.00000	90.00000	0.01377	64	65	66	11
66	-10.66190	0.45916	0.00000	0.45916	0.00000	90.00000	0.01377	65	66	67	11
67	-10.66190	0.91831	0.00000	0.45916	0.00000	90.00000	0.01377	66	67	68	11
68	-10.66190	1.37747	0.00000	0.45916	0.00000	90.00000	0.01377	67	68	69	11
69	-10.66190	1.83662	0.00000	0.45916	0.00000	90.00000	0.01377	68	69	0	11
70	-12.21710	-1.97484	0.00000	0.49371	0.00000	90.00000	0.01481	0	70	71	12
71	-12.21710	-1.48113	0.00000	0.49371	0.00000	90.00000	0.01481	70	71	72	12
72	-12.21710	-0.98742	0.00000	0.49371	0.00000	90.00000	0.01481	71	72	73	12
73	-12.21710	-0.49371	0.00000	0.49371	0.00000	90.00000	0.01481	72	73	74	12
74	-12.21710	0.00000	0.00000	0.49371	0.00000	90.00000	0.01481	73	74	75	12
75	-12.21710	0.49371	0.00000	0.49371	0.00000	90.00000	0.01481	74	75	76	12
76	-12.21710	0.98742	0.00000	0.49371	0.00000	90.00000	0.01481	75	76	77	12
77	-12.21710	1.48113	0.00000	0.49371	0.00000	90.00000	0.01481	76	77	78	12
78	-12.21710	1.97484	0.00000	0.49371	0.00000	90.00000	0.01481	77	78	0	12

```

***** INPUT LINE 1 FR 0 0 0 0 4.62900E+01 0.00000E+00 0.00000E+00 0.00000E+00 0.00000E+00 0.00000E+00
***** INPUT LINE 2 TL 1 3 2 3 -5.00000E+01 0.00000E+00 0.00000E+00 0.00000E+00 0.00000E+00 0.00000E+00
***** INPUT LINE 3 TL 2 3 3 3 -5.00000E+01 0.00000E+00 0.00000E+00 0.00000E+00 0.00000E+00 0.00000E+00
***** INPUT LINE 4 TL 3 3 4 3 -5.00000E+01 0.00000E+00 0.00000E+00 0.00000E+00 0.00000E+00 0.00000E+00
***** INPUT LINE 5 TL 4 3 5 3 -5.00000E+01 0.00000E+00 0.00000E+00 0.00000E+00 0.00000E+00 0.00000E+00
***** INPUT LINE 6 TL 5 3 6 4 -5.00000E+01 0.00000E+00 0.00000E+00 0.00000E+00 0.00000E+00 0.00000E+00
***** INPUT LINE 7 TL 6 4 7 4 -5.00000E+01 0.00000E+00 0.00000E+00 0.00000E+00 0.00000E+00 0.00000E+00
***** INPUT LINE 8 TL 7 4 8 4 -5.00000E+01 0.00000E+00 0.00000E+00 0.00000E+00 0.00000E+00 0.00000E+00

```

```

***** INPUT LINE 9  TL  8  4  9  4 -5.00000E+01  0.00000E+00  0.00000E+00  0.00000E+00  0.00000E+00  0.00000E+00
***** INPUT LINE 10 TL  9  4 10  4 -5.00000E+01  0.00000E+00  0.00000E+00  0.00000E+00  0.00000E+00  0.00000E+00
***** INPUT LINE 11 TL 10  4 11  5 -5.00000E+01  0.00000E+00  0.00000E+00  0.00000E+00  0.00000E+00  0.00000E+00
***** INPUT LINE 12 TL 11  5 12  5 -5.00000E+01  0.00000E+00  0.00000E+00  0.00000E+00  2.00000E-02  0.00000E+00
***** INPUT LINE 13 EX  0  1  3 10  1.00000E+00  0.00000E+00  0.00000E+00  0.00000E+00  0.00000E+00  0.00000E+00
***** INPUT LINE 14 RP  0 37  1 1110 9.00000E+01  0.00000E+00 -5.00000E+00  0.00000E+00  0.00000E+00  0.00000E+00

```

----- FREQUENCY -----

FREQUENCY= 4.6290E+01 MHZ
WAVELENGTH= 6.4766E+00 METERS

--- ANTENNA ENVIRONMENT ---

FREE SPACE

--- STRUCTURE IMPEDANCE LOADING ---

THIS STRUCTURE IS NOT LOADED

--- MATRIX TIMING ---

FILL= 0.340 SEC., FACTOR= 0.030 SEC.

--- NETWORK DATA ---

- FROM -		- TO -		TRANSMISSION LINE		- - SHUNT ADMITTANCES (MHOS) - -				LINE
TAG NO.	SEG. NO.	TAG NO.	SEG. NO.	IMPEDANCE OHMS	LENGTH METERS	- END ONE -		- END TWO -		TYPE
						REAL	IMAG.	REAL	IMAG.	
1	3	2	8	5.0000E+01	7.5270E-01	0.0000E+00	0.0000E+00	0.0000E+00	0.0000E+00	CROSSED
2	8	3	13	5.0000E+01	8.0930E-01	0.0000E+00	0.0000E+00	0.0000E+00	0.0000E+00	CROSSED
3	13	4	18	5.0000E+01	8.7030E-01	0.0000E+00	0.0000E+00	0.0000E+00	0.0000E+00	CROSSED
4	18	5	23	5.0000E+01	9.3570E-01	0.0000E+00	0.0000E+00	0.0000E+00	0.0000E+00	CROSSED
5	23	6	29	5.0000E+01	1.0062E+00	0.0000E+00	0.0000E+00	0.0000E+00	0.0000E+00	CROSSED
6	29	7	36	5.0000E+01	1.0820E+00	0.0000E+00	0.0000E+00	0.0000E+00	0.0000E+00	CROSSED
7	36	8	43	5.0000E+01	1.1633E+00	0.0000E+00	0.0000E+00	0.0000E+00	0.0000E+00	CROSSED
8	43	9	50	5.0000E+01	1.2510E+00	0.0000E+00	0.0000E+00	0.0000E+00	0.0000E+00	CROSSED
9	50	10	57	5.0000E+01	1.3451E+00	0.0000E+00	0.0000E+00	0.0000E+00	0.0000E+00	CROSSED
10	57	11	65	5.0000E+01	1.4463E+00	0.0000E+00	0.0000E+00	0.0000E+00	0.0000E+00	CROSSED
11	65	12	74	5.0000E+01	1.5552E+00	0.0000E+00	0.0000E+00	2.0000E-02	0.0000E+00	CROSSED

--- STRUCTURE EXCITATION DATA AT NETWORK CONNECTION POINTS ---

TAG NO.	SEG. NO.	VOLTAGE (VOLTS)		CURRENT (AMPS)		IMPEDANCE (OHMS)		ADMITTANCE (MHOS)		POWER (WATTS)
		REAL	IMAG.	REAL	IMAG.	REAL	IMAG.	REAL	IMAG.	
2	8	-6.76623E-01	7.27117E-01	-1.88020E-04	-1.90060E-03	3.43987E+02	-3.90034E+02	-1.27189E-03	1.44215E-03	-6.27371E-04
3	13	-1.14159E-01	-1.08175E+00	6.83754E-03	2.28690E-03	6.26068E+01	-1.37268E+02	-2.75049E-03	6.03056E-03	-1.62721E-03
4	18	9.62163E-01	5.03162E-01	-4.58111E-03	1.06822E-02	7.15870E+00	-9.31416E+01	8.20331E-04	1.06733E-02	4.83556E-04
5	23	-7.24746E-01	6.58961E-01	-1.37147E-02	-3.48165E-03	3.81860E+01	-5.77418E+01	7.96822E-03	1.20489E-02	3.82270E-03
6	29	-2.80603E-01	-7.56267E-01	1.69325E-03	-1.27472E-02	5.54261E+01	-2.93753E+01	1.40856E-02	7.46522E-03	4.58258E-03
7	36	5.10311E-01	5.67237E-02	9.62981E-03	-1.19920E-03	5.14613E+01	1.22989E+01	1.83821E-02	-4.39320E-03	2.42309E-03
8	43	-2.44913E-01	2.99246E-01	1.37851E-03	5.04827E-03	4.28354E+01	6.02111E+01	7.84496E-03	-1.10272E-02	5.86529E-04
9	50	-9.82415E-02	-3.60748E-01	-2.30738E-03	5.52679E-04	4.84990E+00	1.57507E+02	1.95308E-04	-6.34290E-03	1.36511E-05
10	57	3.40070E-01	2.78025E-02	3.64284E-04	-9.09741E-04	1.02661E+02	3.32701E+02	8.46834E-04	-2.74439E-03	4.92944E-05
11	65	-9.25180E-02	3.38577E-01	5.72599E-04	5.66603E-04	2.13994E+02	3.79545E+02	1.12719E-03	-1.99921E-03	6.94314E-05
12	74	-2.94603E-01	-1.34908E-01	-7.24946E-04	4.78271E-04	1.97601E+02	3.16458E+02	1.41963E-03	-2.27354E-03	7.45243E-05
1	3	1.00000E+00	0.00000E+00	1.82267E-03	2.30202E-03	2.11411E+02	-2.67012E+02	1.82267E-03	2.30202E-03	9.11334E-04

--- ANTENNA INPUT PARAMETERS ---

TAG NO.	SEG. NO.	VOLTAGE (VOLTS)		CURRENT (AMPS)		IMPEDANCE (OHMS)		ADMITTANCE (MHOS)		POWER (WATTS)
		REAL	IMAG.	REAL	IMAG.	REAL	IMAG.	REAL	IMAG.	
1	3	1.00000E+00	0.00000E+00	2.36240E-02	2.51152E-04	4.23250E+01	-4.49965E-01	2.36240E-02	2.51152E-04	1.18120E-02

- - - CURRENTS AND LOCATION - - -

LENGTHS NORMALIZED BY WAVELENGTH (OR 2.*PI/CABS(K))

SEG. NO.	TAG NO.	COORD. X	OF SEG. Y	CENTER Z	SEG. LENGTH	REAL	IMAG.	MAG.	PHASE
1	1	0.0000	-0.1235	0.0000	0.06176	6.9687E-04	5.6853E-04	8.9937E-04	39.209
2	1	0.0000	-0.0618	0.0000	0.06176	1.5437E-03	1.5720E-03	2.2033E-03	45.520
3	1	0.0000	0.0000	0.0000	0.06176	1.8227E-03	2.3020E-03	2.9362E-03	51.629
4	1	0.0000	0.0618	0.0000	0.06176	1.5437E-03	1.5720E-03	2.2033E-03	45.520
5	1	0.0000	0.1235	0.0000	0.06176	6.9687E-04	5.6853E-04	8.9937E-04	39.209
6	2	-0.1162	-0.1328	0.0000	0.06641	1.9905E-04	-4.7358E-04	5.1371E-04	-67.202
7	2	-0.1162	-0.0664	0.0000	0.06641	1.5343E-04	-1.3185E-03	1.3274E-03	-83.362
8	2	-0.1162	0.0000	0.0000	0.06641	-1.8802E-04	-1.9006E-03	1.9099E-03	-95.650
9	2	-0.1162	0.0664	0.0000	0.06641	1.5343E-04	-1.3185E-03	1.3274E-03	-83.362
10	2	-0.1162	0.1328	0.0000	0.06641	1.9905E-04	-4.7358E-04	5.1371E-04	-67.202
11	3	-0.2412	-0.1428	0.0000	0.07141	2.1561E-03	9.2255E-04	2.3452E-03	23.165
12	3	-0.2412	-0.0714	0.0000	0.07141	5.2780E-03	1.9920E-03	5.6414E-03	20.677
13	3	-0.2412	0.0000	0.0000	0.07141	6.8375E-03	2.2869E-03	7.2098E-03	18.493
14	3	-0.2412	0.0714	0.0000	0.07141	5.2780E-03	1.9920E-03	5.6414E-03	20.677
15	3	-0.2412	0.1428	0.0000	0.07141	2.1561E-03	9.2255E-04	2.3452E-03	23.165
16	4	-0.3756	-0.1536	0.0000	0.07678	-1.5102E-03	3.5732E-03	3.8792E-03	112.911
17	4	-0.3756	-0.0768	0.0000	0.07678	-3.6158E-03	8.5158E-03	9.2516E-03	113.006
18	4	-0.3756	0.0000	0.0000	0.07678	-4.5811E-03	1.0682E-02	1.1623E-02	113.212
19	4	-0.3756	0.0768	0.0000	0.07678	-3.6158E-03	8.5158E-03	9.2516E-03	113.006
20	4	-0.3756	0.1536	0.0000	0.07678	-1.5102E-03	3.5732E-03	3.8792E-03	112.911
21	5	-0.5200	-0.1651	0.0000	0.08256	-4.7271E-03	-9.5696E-04	4.8230E-03	-168.556
22	5	-0.5200	-0.0826	0.0000	0.08256	-1.1146E-02	-2.5364E-03	1.1431E-02	-167.180
23	5	-0.5200	0.0000	0.0000	0.08256	-1.3715E-02	-3.4816E-03	1.4150E-02	-165.756
24	5	-0.5200	0.0826	0.0000	0.08256	-1.1146E-02	-2.5364E-03	1.1431E-02	-167.180
25	5	-0.5200	0.1651	0.0000	0.08256	-4.7271E-03	-9.5696E-04	4.8230E-03	-168.556
26	6	-0.6754	-0.1902	0.0000	0.06341	1.3785E-04	-3.3821E-03	3.3849E-03	-87.666
27	6	-0.6754	-0.1268	0.0000	0.06341	5.5932E-04	-8.3198E-03	8.3386E-03	-86.154
28	6	-0.6754	-0.0634	0.0000	0.06341	1.1491E-03	-1.1516E-02	1.1573E-02	-84.302
29	6	-0.6754	0.0000	0.0000	0.06341	1.6932E-03	-1.2747E-02	1.2859E-02	-82.434
30	6	-0.6754	0.0634	0.0000	0.06341	1.1491E-03	-1.1516E-02	1.1573E-02	-84.302
31	6	-0.6754	0.1268	0.0000	0.06341	5.5932E-04	-8.3198E-03	8.3386E-03	-86.154
32	6	-0.6754	0.1902	0.0000	0.06341	1.3785E-04	-3.3821E-03	3.3849E-03	-87.666
33	7	-0.8425	-0.2046	0.0000	0.06818	2.5956E-03	-5.7066E-04	2.6576E-03	-12.400
34	7	-0.8425	-0.1364	0.0000	0.06818	6.4073E-03	-1.2256E-03	6.5235E-03	-10.829
35	7	-0.8425	-0.0682	0.0000	0.06818	8.8152E-03	-1.3909E-03	8.9242E-03	-8.966
36	7	-0.8425	0.0000	0.0000	0.06818	9.6298E-03	-1.1992E-03	9.7042E-03	-7.098
37	7	-0.8425	0.0682	0.0000	0.06818	8.8152E-03	-1.3909E-03	8.9242E-03	-8.966
38	7	-0.8425	0.1364	0.0000	0.06818	6.4073E-03	-1.2256E-03	6.5235E-03	-10.829
39	7	-0.8425	0.2046	0.0000	0.06818	2.5956E-03	-5.7066E-04	2.6576E-03	-12.400
40	8	-1.0221	-0.2199	0.0000	0.07331	5.2460E-04	1.4102E-03	1.5046E-03	69.595
41	8	-1.0221	-0.1466	0.0000	0.07331	1.1846E-03	3.4851E-03	3.6809E-03	71.227
42	8	-1.0221	-0.0733	0.0000	0.07331	1.4455E-03	4.7327E-03	4.9486E-03	73.015
43	8	-1.0221	0.0000	0.0000	0.07331	1.3785E-03	5.0483E-03	5.2331E-03	74.727
44	8	-1.0221	0.0733	0.0000	0.07331	1.4455E-03	4.7327E-03	4.9486E-03	73.015
45	8	-1.0221	0.1466	0.0000	0.07331	1.1846E-03	3.4851E-03	3.6809E-03	71.227
46	8	-1.0221	0.2199	0.0000	0.07331	5.2460E-04	1.4102E-03	1.5046E-03	69.595
47	9	-1.2152	-0.2365	0.0000	0.07883	-7.4268E-04	2.0205E-04	7.6967E-04	164.781
48	9	-1.2152	-0.1577	0.0000	0.07883	-1.7937E-03	4.6194E-04	1.8522E-03	165.558
49	9	-1.2152	-0.0788	0.0000	0.07883	-2.3194E-03	5.7087E-04	2.3886E-03	166.173
50	9	-1.2152	0.0000	0.0000	0.07883	-2.3074E-03	5.5268E-04	2.3726E-03	166.530
51	9	-1.2152	0.0788	0.0000	0.07883	-2.3194E-03	5.7087E-04	2.3886E-03	166.173
52	9	-1.2152	0.1577	0.0000	0.07883	-1.7937E-03	4.6194E-04	1.8522E-03	165.558
53	9	-1.2152	0.2365	0.0000	0.07883	-7.4268E-04	2.0205E-04	7.6967E-04	164.781
54	10	-1.4229	-0.2543	0.0000	0.08477	9.5835E-05	-3.9100E-04	4.0258E-04	-76.228
55	10	-1.4229	-0.1695	0.0000	0.08477	2.4963E-04	-8.9811E-04	9.3216E-04	-74.467
56	10	-1.4229	-0.0848	0.0000	0.08477	3.4553E-04	-1.0569E-03	1.1120E-03	-71.896
57	10	-1.4229	0.0000	0.0000	0.08477	3.6428E-04	-9.0974E-04	9.7997E-04	-68.178
58	10	-1.4229	0.0848	0.0000	0.08477	3.4553E-04	-1.0569E-03	1.1120E-03	-71.896
59	10	-1.4229	0.1695	0.0000	0.08477	2.4963E-04	-8.9811E-04	9.3216E-04	-74.467
60	10	-1.4229	0.2543	0.0000	0.08477	9.5835E-05	-3.9100E-04	4.0258E-04	-76.228
61	11	-1.6462	-0.2836	0.0000	0.07089	2.7083E-04	1.5013E-04	3.0966E-04	29.002
62	11	-1.6462	-0.2127	0.0000	0.07089	6.3258E-04	3.7778E-04	7.3680E-04	30.846
63	11	-1.6462	-0.1418	0.0000	0.07089	8.0840E-04	5.3308E-04	9.6834E-04	33.402
64	11	-1.6462	-0.0709	0.0000	0.07089	7.6870E-04	5.9463E-04	9.7184E-04	37.724
65	11	-1.6462	0.0000	0.0000	0.07089	5.7260E-04	5.6660E-04	8.0555E-04	44.698
66	11	-1.6462	0.0709	0.0000	0.07089	7.6870E-04	5.9463E-04	9.7184E-04	37.724
67	11	-1.6462	0.1418	0.0000	0.07089	8.0840E-04	5.3308E-04	9.6834E-04	33.402
68	11	-1.6462	0.2127	0.0000	0.07089	6.3258E-04	3.7778E-04	7.3680E-04	30.846
69	11	-1.6462	0.2836	0.0000	0.07089	2.7083E-04	1.5013E-04	3.0966E-04	29.002
70	12	-1.8864	-0.3049	0.0000	0.07623	-1.9982E-04	2.4060E-04	3.1276E-04	129.711
71	12	-1.8864	-0.2287	0.0000	0.07623	-5.0501E-04	5.6276E-04	7.5613E-04	131.904
72	12	-1.8864	-0.1525	0.0000	0.07623	-7.0919E-04	7.1452E-04	1.0067E-03	134.786
73	12	-1.8864	-0.0762	0.0000	0.07623	-7.7887E-04	6.6669E-04	1.0252E-03	139.438

74	12	-1.8864	0.0000	0.0000	0.07623	-7.2495E-04	4.7827E-04	8.6850E-04	146.586
75	12	-1.8864	0.0762	0.0000	0.07623	-7.7887E-04	6.6669E-04	1.0252E-03	139.438
76	12	-1.8864	0.1525	0.0000	0.07623	-7.0919E-04	7.1452E-04	1.0067E-03	134.786
77	12	-1.8864	0.2287	0.0000	0.07623	-5.0501E-04	5.6276E-04	7.5613E-04	131.904
78	12	-1.8864	0.3049	0.0000	0.07623	-1.9982E-04	2.4060E-04	3.1276E-04	129.711

--- POWER BUDGET ---

INPUT POWER = 1.1812E-02 WATTS
 RADIATED POWER = 1.0762E-02 WATTS
 WIRE LOSS = 0.0000E+00 WATTS
 NETWORK LOSS = 1.0499E-03 WATTS
 EFFICIENCY = 91.11 PERCENT

--- RADIATION PATTERNS ---

-- ANGLES --		- DIRECTIVE GAINS -			--- POLARIZATION ---			--- E(THETA) ---		--- E(PHI) ---	
THETA DEGREES	PHI DEGREES	VERT. DB	HOR. DB	TOTAL DB	AXIAL RATIO	TILT DEG.	SENSE	MAGNITUDE VOLTS	PHASE DEGREES	MAGNITUDE VOLTS	PHASE DEGREES
90.00	0.00	-999.99	9.75	9.75	0.00000	90.00	LINEAR	0.00000E+00	0.00	2.46920E+00	-65.98
85.00	0.00	-999.99	9.70	9.70	0.00000	90.00	LINEAR	0.00000E+00	0.00	2.45350E+00	-65.18
80.00	0.00	-999.99	9.53	9.53	0.00000	90.00	LINEAR	0.00000E+00	0.00	2.40688E+00	-62.81
75.00	0.00	-999.99	9.25	9.25	0.00000	90.00	LINEAR	0.00000E+00	0.00	2.33092E+00	-58.95
70.00	0.00	-999.99	8.86	8.86	0.00000	90.00	LINEAR	0.00000E+00	0.00	2.22887E+00	-53.73
65.00	0.00	-999.99	8.37	8.37	0.00000	90.00	LINEAR	0.00000E+00	0.00	2.10615E+00	-47.29
60.00	0.00	-999.99	7.79	7.79	0.00000	90.00	LINEAR	0.00000E+00	0.00	1.97021E+00	-39.76
55.00	0.00	-999.99	7.15	7.15	0.00000	90.00	LINEAR	0.00000E+00	0.00	1.82914E+00	-31.16
50.00	0.00	-999.99	6.45	6.45	0.00000	90.00	LINEAR	0.00000E+00	0.00	1.68846E+00	-21.32
45.00	0.00	-999.99	5.69	5.69	0.00000	90.00	LINEAR	0.00000E+00	0.00	1.54743E+00	-9.89
40.00	0.00	-999.99	4.81	4.81	0.00000	90.00	LINEAR	0.00000E+00	0.00	1.39754E+00	3.58
35.00	0.00	-999.99	3.67	3.67	0.00000	90.00	LINEAR	0.00000E+00	0.00	1.22596E+00	19.49
30.00	0.00	-999.99	2.10	2.10	0.00000	90.00	LINEAR	0.00000E+00	0.00	1.02309E+00	38.03
25.00	0.00	-999.99	-0.14	-0.14	0.00000	90.00	LINEAR	0.00000E+00	0.00	7.90294E-01	59.28
20.00	0.00	-999.99	-3.40	-3.40	0.00000	90.00	LINEAR	0.00000E+00	0.00	5.43336E-01	83.44
15.00	0.00	-999.99	-8.27	-8.27	0.00000	90.00	LINEAR	0.00000E+00	0.00	3.10050E-01	111.79
10.00	0.00	-999.99	-16.14	-16.14	0.00000	90.00	LINEAR	0.00000E+00	0.00	1.25251E-01	152.61
5.00	0.00	-999.99	-23.14	-23.14	0.00000	90.00	LINEAR	0.00000E+00	0.00	5.59476E-02	-103.86
0.00	0.00	-999.99	-19.63	-19.63	0.00000	90.00	LINEAR	0.00000E+00	0.00	8.38503E-02	-41.94
-5.00	0.00	-999.99	-20.65	-20.65	0.00000	90.00	LINEAR	0.00000E+00	0.00	7.45439E-02	-24.90
-10.00	0.00	-999.99	-22.13	-22.13	0.00000	90.00	LINEAR	0.00000E+00	0.00	6.28669E-02	-47.75
-15.00	0.00	-999.99	-17.70	-17.70	0.00000	90.00	LINEAR	0.00000E+00	0.00	1.04658E-01	-62.54
-20.00	0.00	-999.99	-14.43	-14.43	0.00000	90.00	LINEAR	0.00000E+00	0.00	1.52461E-01	-50.17
-25.00	0.00	-999.99	-13.31	-13.31	0.00000	90.00	LINEAR	0.00000E+00	0.00	1.73492E-01	-30.85
-30.00	0.00	-999.99	-13.96	-13.96	0.00000	90.00	LINEAR	0.00000E+00	0.00	1.60993E-01	-10.65
-35.00	0.00	-999.99	-16.41	-16.41	0.00000	90.00	LINEAR	0.00000E+00	0.00	1.21403E-01	7.53
-40.00	0.00	-999.99	-21.42	-21.42	0.00000	90.00	LINEAR	0.00000E+00	0.00	6.82457E-02	18.35
-45.00	0.00	-999.99	-29.96	-29.96	0.00000	90.00	LINEAR	0.00000E+00	0.00	2.55077E-02	-16.59
-50.00	0.00	-999.99	-24.33	-24.33	0.00000	90.00	LINEAR	0.00000E+00	0.00	4.87952E-02	-74.37
-55.00	0.00	-999.99	-19.91	-19.91	0.00000	90.00	LINEAR	0.00000E+00	0.00	8.11637E-02	-72.26
-60.00	0.00	-999.99	-17.99	-17.99	0.00000	90.00	LINEAR	0.00000E+00	0.00	1.01248E-01	-63.60
-65.00	0.00	-999.99	-17.28	-17.28	0.00000	90.00	LINEAR	0.00000E+00	0.00	1.09830E-01	-55.16
-70.00	0.00	-999.99	-17.24	-17.24	0.00000	90.00	LINEAR	0.00000E+00	0.00	1.10383E-01	-48.42
-75.00	0.00	-999.99	-17.53	-17.53	0.00000	90.00	LINEAR	0.00000E+00	0.00	1.06732E-01	-43.74
-80.00	0.00	-999.99	-17.92	-17.92	0.00000	90.00	LINEAR	0.00000E+00	0.00	1.02055E-01	-40.95
-85.00	0.00	-999.99	-18.23	-18.23	0.00000	90.00	LINEAR	0.00000E+00	0.00	9.84969E-02	-39.61
-90.00	0.00	-999.99	-18.34	-18.34	0.00000	90.00	LINEAR	0.00000E+00	0.00	9.71973E-02	-39.23

--- NORMALIZED GAIN ---

MAJOR AXIS GAIN
 NORMALIZATION FACTOR = 9.75 DB

-- ANGLES --		GAIN DB	-- ANGLES --		GAIN DB	-- ANGLES --		GAIN DB
THETA DEGREES	PHI DEGREES		THETA DEGREES	PHI DEGREES		THETA DEGREES	PHI DEGREES	
90.00	0.00	0.00	25.00	0.00	-9.90	-35.00	0.00	-26.17
85.00	0.00	-0.06	20.00	0.00	-13.15	-40.00	0.00	-31.17
80.00	0.00	-0.22	15.00	0.00	-18.02	-45.00	0.00	-39.72
75.00	0.00	-0.50	10.00	0.00	-25.90	-50.00	0.00	-34.08
70.00	0.00	-0.89	5.00	0.00	-32.90	-55.00	0.00	-29.66
65.00	0.00	-1.38	0.00	0.00	-29.38	-60.00	0.00	-27.74
60.00	0.00	-1.96	-5.00	0.00	-30.40	-65.00	0.00	-27.04
55.00	0.00	-2.61	-10.00	0.00	-31.88	-70.00	0.00	-26.99

50.00	0.00	-3.30	-15.00	0.00	-27.46	-75.00	0.00	-27.29
45.00	0.00	-4.06	-20.00	0.00	-24.19	-80.00	0.00	-27.67
40.00	0.00	-4.94	-25.00	0.00	-23.07	-85.00	0.00	-27.98
35.00	0.00	-6.08	-30.00	0.00	-23.71	-90.00	0.00	-28.10
30.00	0.00	-7.65						

***** INPUT LINE 15 EN 0 0 0 0 0.00000E+00 0.00000E+00 0.00000E+00 0.00000E+00 0.00000E+00 0.00000E+00

RUN TIME = 0.650

4.2.3 Example 6, Cylinder with Attached Wires

The structure data for the cylinder with attached wires was discussed in section 3.4. In this example, the wire on the end of the cylinder is excited first, and a radiation pattern is computed. The CP command requests the coupling between the base segments of the two wires. The coupling printed is the maximum that would occur when the source and load are simultaneously matched to their antennas. The table includes the matched load impedance for the second segment and the corresponding input impedance at the first segment. The source impedance would be the conjugate of this input impedance for maximum coupling.

Input for Example 6

```

CECYLINDER WITH ATTACHED WIRES.
SP 0 0 10. 0. 7.3333 0. 0. 38.4
SP 0 0 10. 0. 0. 0. 0. 38.4
SP 0 0 10. 0. -7.3333 0. 0. 38.4
GM 0 1 0. 0. 30.
SP 0 0 6.89 0. 11. 90. 0. 44.88
SP 0 0 6.89 0. -11. -90. 0. 44.88
GR 0 6
SP 0 0 0. 0. 11. 90. 0. 44.89
SP 0 0 0. 0. -11. -90. 0. 44.89
GW 1 4 0. 0. 11. 0. 0. 23. .1
GW 2 5 10. 0. 0. 27.6 0. 0. .2
GS 0 0 .01
GE
FR 0 1 0 0 465.84
CP 1 1 2 1
EX 0 1 1 0 1.
RP 0 73 1 1000 0. 0. 5. 0.
EX 0 2 1 0 1.
XQ
EN

```

Output for Example 6

```

*****
*
* NUMERICAL ELECTROMAGNETICS CODE (NEC-4.1)
*
*****
    
```

```

*****
CYLINDER WITH ATTACHED WIRES.
*****
    
```

- - - STRUCTURE SPECIFICATION - - -

COORDINATES MUST BE INPUT IN
METERS OR BE SCALED TO METERS
BEFORE STRUCTURE INPUT IS ENDED

WIRE NO.	X1	Y1	Z1	X2	Y2	Z2	RADIUS	NO. OF SEG.	FIRST SEG.	LAST SEG.	TAG NO.
1P	10.00000	0.00000	7.33330	0.00000	0.00000	38.40000					
2P	10.00000	0.00000	0.00000	0.00000	0.00000	38.40000					
3P	10.00000	0.00000	-7.33330	0.00000	0.00000	38.40000					
THE STRUCTURE HAS BEEN MOVED, GM COMMAND DATA IS -											
0	1	0.00000	0.00000	30.00000	0.00000	0.00000	0.00000	0	1	0	1
7P	6.89000	0.00000	11.00000	90.00000	0.00000	44.88000					
8P	6.89000	0.00000	-11.00000	-90.00000	0.00000	44.88000					
STRUCTURE ROTATED ABOUT Z-AXIS 6 TIMES. LABELS INCREMENTED BY 0											
49P	0.00000	0.00000	11.00000	90.00000	0.00000	44.89000					
50P	0.00000	0.00000	-11.00000	-90.00000	0.00000	44.89000					
1	0.00000	0.00000	11.00000	0.00000	0.00000	23.00000	0.10000	4	1	4	1
2	10.00000	0.00000	0.00000	27.60000	0.00000	0.00000	0.20000	5	5	9	2
STRUCTURE SCALED BY FACTOR 0.01000											

TOTAL SEGMENTS USED= 9 NO. SEG. IN A SYMMETRIC CELL= 9 SYMMETRY FLAG= 0
 TOTAL PATCHES USED= 56 NO. PATCHES IN A SYMMETRIC CELL= 56

- MULTIPLE WIRE JUNCTIONS -
 JUNCTION SEGMENTS (- FOR END 1, + FOR END 2)
 NONE

- - - - SEGMENTATION DATA - - - -

COORDINATES IN METERS

I+ AND I- INDICATE THE SEGMENTS BEFORE AND AFTER I

SEG. NO.	COORDINATES OF SEG. CENTER			SEG. LENGTH	ORIENTATION ANGLES		WIRE RADIUS	CONNECTION DATA			TAG NO.
	X	Y	Z		ALPHA	BETA		I-	I	I+	
1	0.00000	0.00000	0.12500	0.03000	90.00000	0.00000	0.00100	10052	1	2	1
2	0.00000	0.00000	0.15500	0.03000	90.00000	0.00000	0.00100		1	3	1
3	0.00000	0.00000	0.18500	0.03000	90.00000	0.00000	0.00100		2	4	1
4	0.00000	0.00000	0.21500	0.03000	90.00000	0.00000	0.00100		3	0	1
5	0.11760	0.00000	0.00000	0.03520	0.00000	0.00000	0.00200	10002	5	6	2
6	0.15280	0.00000	0.00000	0.03520	0.00000	0.00000	0.00200		5	7	2
7	0.18800	0.00000	0.00000	0.03520	0.00000	0.00000	0.00200		6	8	2
8	0.22320	0.00000	0.00000	0.03520	0.00000	0.00000	0.00200		7	9	2
9	0.25840	0.00000	0.00000	0.03520	0.00000	0.00000	0.00200		8	0	2

- - - SURFACE PATCH DATA - - -

COORDINATES IN METERS

PATCH NO.	COORD. OF PATCH CENTER			UNIT NORMAL VECTOR			PATCH AREA	COMPONENTS OF UNIT TANGENT VECTORS						
	X	Y	Z	X	Y	Z		X1	Y1	Z1	X2	Y2	Z2	
1	0.10000	0.00000	0.07333	1.0000	0.0000	0.0000	0.00384	0.0000	1.0000	0.0000	0.0000	0.0000	0.0000	1.0000
2	0.10000	0.01549	0.01549	1.0000	0.0000	0.0000	0.00096	0.0000	1.0000	0.0000	0.0000	0.0000	0.0000	1.0000
3	0.10000	-0.01549	0.01549	1.0000	0.0000	0.0000	0.00096	0.0000	1.0000	0.0000	0.0000	0.0000	0.0000	1.0000
4	0.10000	-0.01549	-0.01549	1.0000	0.0000	0.0000	0.00096	0.0000	1.0000	0.0000	0.0000	0.0000	0.0000	1.0000
5	0.10000	0.01549	-0.01549	1.0000	0.0000	0.0000	0.00096	0.0000	1.0000	0.0000	0.0000	0.0000	0.0000	1.0000
6	0.10000	0.00000	-0.07333	1.0000	0.0000	0.0000	0.00384	0.0000	1.0000	0.0000	0.0000	0.0000	0.0000	1.0000
7	0.08660	0.05000	0.07333	0.8660	0.5000	0.0000	0.00384	-0.5000	0.8660	0.0000	0.0000	0.0000	0.0000	1.0000
8	0.08660	0.05000	0.00000	0.8660	0.5000	0.0000	0.00384	-0.5000	0.8660	0.0000	0.0000	0.0000	0.0000	1.0000
9	0.08660	0.05000	-0.07333	0.8660	0.5000	0.0000	0.00384	-0.5000	0.8660	0.0000	0.0000	0.0000	0.0000	1.0000
10	0.06890	0.00000	0.11000	0.0000	0.0000	1.0000	0.00449	1.0000	0.0000	0.0000	0.0000	1.0000	0.0000	0.0000
11	0.06890	0.00000	-0.11000	0.0000	0.0000	-1.0000	0.00449	1.0000	0.0000	0.0000	0.0000	-1.0000	0.0000	0.0000
12	0.05000	0.08660	0.07333	0.5000	0.8660	0.0000	0.00384	-0.8660	0.5000	0.0000	0.0000	0.0000	0.0000	1.0000
13	0.05000	0.08660	0.00000	0.5000	0.8660	0.0000	0.00384	-0.8660	0.5000	0.0000	0.0000	0.0000	0.0000	1.0000
14	0.05000	0.08660	-0.07333	0.5000	0.8660	0.0000	0.00384	-0.8660	0.5000	0.0000	0.0000	0.0000	0.0000	1.0000
15	0.00000	0.10000	0.07333	0.0000	1.0000	0.0000	0.00384	-1.0000	0.0000	0.0000	0.0000	0.0000	0.0000	1.0000
16	0.00000	0.10000	0.00000	0.0000	1.0000	0.0000	0.00384	-1.0000	0.0000	0.0000	0.0000	0.0000	0.0000	1.0000
17	0.00000	0.10000	-0.07333	0.0000	1.0000	0.0000	0.00384	-1.0000	0.0000	0.0000	0.0000	0.0000	0.0000	1.0000
18	0.03445	0.05967	0.11000	0.0000	0.0000	1.0000	0.00449	0.5000	0.8660	0.0000	-0.8660	0.5000	0.0000	0.0000
19	0.03445	0.05967	-0.11000	0.0000	0.0000	-1.0000	0.00449	0.5000	0.8660	0.0000	0.8660	-0.5000	0.0000	0.0000
20	-0.05000	0.08660	0.07333	-0.5000	0.8660	0.0000	0.00384	-0.8660	-0.5000	0.0000	0.0000	0.0000	0.0000	1.0000
21	-0.05000	0.08660	0.00000	-0.5000	0.8660	0.0000	0.00384	-0.8660	-0.5000	0.0000	0.0000	0.0000	0.0000	1.0000
22	-0.05000	0.08660	-0.07333	-0.5000	0.8660	0.0000	0.00384	-0.8660	-0.5000	0.0000	0.0000	0.0000	0.0000	1.0000
23	-0.08660	0.05000	0.07333	-0.8660	0.5000	0.0000	0.00384	-0.5000	-0.8660	0.0000	0.0000	0.0000	0.0000	1.0000
24	-0.08660	0.05000	0.00000	-0.8660	0.5000	0.0000	0.00384	-0.5000	-0.8660	0.0000	0.0000	0.0000	0.0000	1.0000
25	-0.08660	0.05000	-0.07333	-0.8660	0.5000	0.0000	0.00384	-0.5000	-0.8660	0.0000	0.0000	0.0000	0.0000	1.0000
26	-0.03445	0.05967	0.11000	0.0000	0.0000	1.0000	0.00449	-0.5000	0.8660	0.0000	-0.8660	-0.5000	0.0000	0.0000
27	-0.03445	0.05967	-0.11000	0.0000	0.0000	-1.0000	0.00449	-0.5000	0.8660	0.0000	0.8660	0.5000	0.0000	0.0000
28	-0.10000	0.00000	0.07333	-1.0000	0.0000	0.0000	0.00384	0.0000	-1.0000	0.0000	0.0000	0.0000	0.0000	1.0000
29	-0.10000	0.00000	0.00000	-1.0000	0.0000	0.0000	0.00384	0.0000	-1.0000	0.0000	0.0000	0.0000	0.0000	1.0000
30	-0.10000	0.00000	-0.07333	-1.0000	0.0000	0.0000	0.00384	0.0000	-1.0000	0.0000	0.0000	0.0000	0.0000	1.0000
31	-0.08660	-0.05000	0.07333	-0.8660	-0.5000	0.0000	0.00384	0.5000	-0.8660	0.0000	0.0000	0.0000	0.0000	1.0000
32	-0.08660	-0.05000	0.00000	-0.8660	-0.5000	0.0000	0.00384	0.5000	-0.8660	0.0000	0.0000	0.0000	0.0000	1.0000
33	-0.08660	-0.05000	-0.07333	-0.8660	-0.5000	0.0000	0.00384	0.5000	-0.8660	0.0000	0.0000	0.0000	0.0000	1.0000
34	-0.06890	0.00000	0.11000	0.0000	0.0000	1.0000	0.00449	-1.0000	0.0000	0.0000	0.0000	-1.0000	0.0000	0.0000
35	-0.06890	0.00000	-0.11000	0.0000	0.0000	-1.0000	0.00449	-1.0000	0.0000	0.0000	0.0000	1.0000	0.0000	0.0000
36	-0.05000	-0.08660	0.07333	-0.5000	-0.8660	0.0000	0.00384	0.8660	-0.5000	0.0000	0.0000	0.0000	0.0000	1.0000
37	-0.05000	-0.08660	0.00000	-0.5000	-0.8660	0.0000	0.00384	0.8660	-0.5000	0.0000	0.0000	0.0000	0.0000	1.0000
38	-0.05000	-0.08660	-0.07333	-0.5000	-0.8660	0.0000	0.00384	0.8660	-0.5000	0.0000	0.0000	0.0000	0.0000	1.0000
39	0.00000	-0.10000	0.07333	0.0000	-1.0000	0.0000	0.00384	1.0000	0.0000	0.0000	0.0000	0.0000	0.0000	1.0000
40	0.00000	-0.10000	0.00000	0.0000	-1.0000	0.0000	0.00384	1.0000	0.0000	0.0000	0.0000	0.0000	0.0000	1.0000
41	0.00000	-0.10000	-0.07333	0.0000	-1.0000	0.0000	0.00384	1.0000	0.0000	0.0000	0.0000	0.0000	0.0000	1.0000
42	-0.03445	-0.05967	0.11000	0.0000	0.0000	1.0000	0.00449	-0.5000	-0.8660	0.0000	0.8660	-0.5000	0.0000	0.0000
43	-0.03445	-0.05967	-0.11000	0.0000	0.0000	-1.0000	0.00449	-0.5000	-0.8660	0.0000	-0.8660	0.5000	0.0000	0.0000
44	0.05000	-0.08660	0.07333	0.5000	-0.8660	0.0000	0.00384	0.8660	0.5000	0.0000	0.0000	0.0000	0.0000	1.0000
45	0.05000	-0.08660	0.00000	0.5000	-0.8660	0.0000	0.00384	0.8660	0.5000	0.0000	0.0000	0.0000	0.0000	1.0000
46	0.05000	-0.08660	-0.07333	0.5000	-0.8660	0.0000	0.00384	0.8660	0.5000	0.0000	0.0000	0.0000	0.0000	1.0000
47	0.08660	-0.05000	0.07333	0.8660	-0.5000	0.0000	0.00384	0.5000	0.8660	0.0000	0.0000	0.0000	0.0000	1.0000
48	0.08660	-0.05000	0.00000	0.8660	-0.5000	0.0000	0.00384	0.5000	0.8660	0.0000	0.0000	0.0000	0.0000	1.0000
49	0.08660	-0.05000	-0.07333	0.8660	-0.5000	0.0000	0.00384	0.5000	0.8660	0.0000	0.0000	0.0000	0.0000	1.0000
50	0.03445	-0.05967	0.11000	0.0000	0.0000	1.0000	0.00449	0.5000	-0.8660	0.0000	0.8660	0.5000	0.0000	0.0000
51	0.03445	-0.05967	-0.11000	0.0000	0.0000	-1.0000	0.00449	0.5000	-0.8660	0.0000	-0.8660	-0.5000	0.0000	0.0000
52	0.01675	0.01675	0.11000	0.0000	0.0000	1.0000	0.00112	1.0000	-0.0000	0.0000	0.0000	1.0000	0.0000	0.0000
53	-0.01675	0.01675	0.11000	0.0000	0.0000	1.0000	0.00112	1.0000	0.0000	0.0000	0.0000	1.0000	0.0000	0.0000
54	-0.01675	-0.01675	0.11000	0.0000	0.0000	1.0000	0.00112	1.0000	0.0000	0.0000	0.0000	1.0000	0.0000	0.0000
55	0.01675	-0.01675	0.11000	0.0000	0.0000	1.0000	0.00112	1.0000	0.0000	0.0000	0.0000	1.0000	0.0000	0.0000
56	0.00000	0.00000	-0.11000	0.0000	0.0000	-1.0000	0.00449	1.0000	0.0000	0.0000	0.0000	-1.0000	0.0000	0.0000

***** INPUT LINE 1 FR 0 1 0 0 4.65840E+02 0.00000E+00 0.00000E+00 0.00000E+00 0.00000E+00 0.00000E+00
 ***** INPUT LINE 2 CP 1 1 2 1 0.00000E+00 0.00000E+00 0.00000E+00 0.00000E+00 0.00000E+00 0.00000E+00

- - - - - FREQUENCY - - - - -
 FREQUENCY= 4.6584E+02 MHZ
 WAVELENGTH= 6.4357E-01 METERS

--- ANTENNA ENVIRONMENT ---

FREE SPACE

--- STRUCTURE IMPEDANCE LOADING ---

THIS STRUCTURE IS NOT LOADED

--- MATRIX TIMING ---

FILL= 0.120 SEC., FACTOR= 0.150 SEC.

--- ISOLATION DATA ---

-- COUPLING BETWEEN --						MAXIMUM	-- FOR MAXIMUM COUPLING --			
TAG/SEG.	SEG. NO.	TAG/SEG.	SEG. NO.	SEG. NO.	SEG. NO.	COUPLING (DB)	LOAD IMPEDANCE (2ND SEG.)		INPUT IMPEDANCE	
							REAL	IMAG.	REAL	IMAG.
1	1	1	2	1	5	-13.722	5.58110E+01	-2.06401E+01	1.82306E+01	-1.16448E+02

```

***** INPUT LINE 3 EX 0 1 1 0 1.00000E+00 0.00000E+00 0.00000E+00 0.00000E+00 0.00000E+00 0.00000E+00
***** INPUT LINE 4 RP 0 73 1 1000 0.00000E+00 0.00000E+00 5.00000E+00 0.00000E+00 0.00000E+00 0.00000E+00

```

--- ANTENNA INPUT PARAMETERS ---

TAG NO.	SEG. NO.	VOLTAGE (VOLTS)		CURRENT (AMPS)		IMPEDANCE (OHMS)		ADMITTANCE (MHOS)		POWER (WATTS)
		REAL	IMAG.	REAL	IMAG.	REAL	IMAG.	REAL	IMAG.	
1	1	1.00000E+00	0.00000E+00	1.25123E-03	8.29193E-03	1.77930E+01	-1.17914E+02	1.25123E-03	8.29193E-03	6.25616E-04

--- CURRENTS AND LOCATION ---

LENGTHS NORMALIZED BY WAVELENGTH (OR 2.*PI/CABS(K))

SEG. NO.	TAG NO.	COORD. OF SEG. CENTER			SEG. LENGTH	CURRENT (AMPS)			PHASE
		X	Y	Z		REAL	IMAG.	MAG.	
1	1	0.0000	0.0000	0.1942	0.04662	1.2512E-03	8.2919E-03	8.3858E-03	81.419
2	1	0.0000	0.0000	0.2408	0.04662	1.0974E-03	6.5797E-03	6.6706E-03	80.531
3	1	0.0000	0.0000	0.2875	0.04662	7.9160E-04	4.3755E-03	4.4465E-03	79.745
4	1	0.0000	0.0000	0.3341	0.04662	3.3072E-04	1.7249E-03	1.7563E-03	79.146
5	2	0.1827	0.0000	0.0000	0.05470	-7.5950E-04	1.5535E-03	1.7292E-03	116.053
6	2	0.2374	0.0000	0.0000	0.05470	-7.0187E-04	1.4308E-03	1.5937E-03	116.130
7	2	0.2921	0.0000	0.0000	0.05470	-5.8468E-04	1.1901E-03	1.3260E-03	116.163
8	2	0.3468	0.0000	0.0000	0.05470	-4.0822E-04	8.3176E-04	9.2653E-04	116.141
9	2	0.4015	0.0000	0.0000	0.05470	-1.7005E-04	3.4744E-04	3.8682E-04	116.078

--- SURFACE PATCH CURRENTS ---

DISTANCES IN WAVELENGTHS (2.*PI/CABS(K))
CURRENT IN AMPS/METER

PATCH NO.	PATCH CENTER			-- SURFACE COMPONENTS --				-- RECTANGULAR COMPONENTS --					
	X	Y	Z	TANGENT VECTOR 1		TANGENT VECTOR 2		X		Y		Z	
				MAG.	PHASE	MAG.	PHASE	REAL	IMAG.	REAL	IMAG.	REAL	IMAG.
1	0.155	0.000	0.114	2.4106E-12	68.37	7.1971E-03	-35.22	0.00E+00	0.00E+00	8.89E-13	2.24E-12	5.88E-03	-4.15E-03
2	0.155	0.024	0.024	9.0028E-03	-65.45	1.4222E-02	-51.34	0.00E+00	0.00E+00	3.74E-03	-8.19E-03	8.88E-03	-1.11E-02
3	0.155	-0.024	0.024	9.0028E-03	114.55	1.4222E-02	-51.34	0.00E+00	0.00E+00	-3.74E-03	8.19E-03	8.88E-03	-1.11E-02
4	0.155	-0.024	-0.024	9.0097E-03	114.50	5.0969E-03	84.34	0.00E+00	0.00E+00	-3.74E-03	8.20E-03	5.03E-04	5.07E-03
5	0.155	0.024	-0.024	9.0097E-03	-65.50	5.0969E-03	84.34	0.00E+00	0.00E+00	3.74E-03	-8.20E-03	5.03E-04	5.07E-03
6	0.155	0.000	-0.114	6.8371E-13	-4.53	1.5963E-03	12.56	0.00E+00	0.00E+00	6.82E-13	-5.40E-14	1.56E-03	3.47E-04
7													

0.135	0.078	0.114	1.8796E-03	-94.86	5.5431E-03	-11.30	7.96E-05	9.36E-04	-1.38E-04	-1.62E-03	5.44E-03	-1.09E-03
8												
0.135	0.078	0.000	3.9155E-03	-75.48	5.3136E-03	-33.00	-4.91E-04	1.90E-03	8.50E-04	-3.28E-03	4.46E-03	-2.89E-03
9												
0.135	0.078	-0.114	1.8136E-03	-94.59	2.9175E-03	-33.42	7.26E-05	9.04E-04	-1.26E-04	-1.57E-03	2.44E-03	-1.61E-03
10												
0.107	0.000	0.171	1.3690E-02	-104.81	2.5898E-12	102.38	-3.50E-03	-1.32E-02	-5.55E-13	2.53E-12	0.00E+00	0.00E+00
11												
0.107	0.000	-0.171	1.5185E-03	-10.60	1.2039E-12	-163.52	1.49E-03	-2.79E-04	1.15E-12	3.42E-13	0.00E+00	0.00E+00
12												
0.078	0.135	0.114	1.6708E-03	-129.80	4.7412E-03	-8.86	9.26E-04	1.11E-03	-5.35E-04	-6.42E-04	4.68E-03	-7.30E-04
13												
0.078	0.135	0.000	1.6297E-03	-112.83	5.3696E-03	-33.12	5.48E-04	1.30E-03	-3.16E-04	-7.51E-04	4.50E-03	-2.93E-03
14												
0.078	0.135	-0.114	1.7229E-03	-128.57	4.1502E-03	-48.62	9.30E-04	1.17E-03	-5.37E-04	-6.74E-04	2.74E-03	-3.11E-03
15												
0.000	0.155	0.114	1.4453E-03	-160.33	5.3230E-03	11.87	1.36E-03	4.86E-04	1.88E-13	6.73E-14	5.21E-03	1.09E-03
16												
0.000	0.155	0.000	1.2076E-03	-155.47	5.3687E-03	-32.95	1.10E-03	5.01E-04	1.52E-13	6.94E-14	4.51E-03	-2.92E-03
17												
0.000	0.155	-0.114	1.4418E-03	-160.25	4.6029E-03	-54.61	1.36E-03	4.87E-04	1.88E-13	6.75E-14	2.67E-03	-3.75E-03
18												
0.054	0.093	0.171	1.4844E-02	-105.23	1.6079E-03	-145.63	-8.01E-04	-6.38E-03	-4.04E-03	-1.29E-02	0.00E+00	0.00E+00
19												
0.054	0.093	-0.171	1.7546E-03	-50.90	1.6066E-03	35.03	1.69E-03	1.18E-04	3.00E-04	-1.64E-03	0.00E+00	0.00E+00
20												
-0.078	0.135	0.114	1.3171E-03	-178.67	5.0407E-03	-2.54	1.14E-03	2.65E-05	6.58E-04	1.53E-05	5.04E-03	-2.24E-04
21												
-0.078	0.135	0.000	9.9513E-04	178.65	5.3741E-03	-33.13	8.62E-04	-2.04E-05	4.97E-04	-1.18E-05	4.50E-03	-2.94E-03
22												
-0.078	0.135	-0.114	1.3021E-03	178.63	4.3368E-03	-56.63	1.13E-03	-2.69E-05	6.51E-04	-1.56E-05	2.39E-03	-3.62E-03
23												
-0.135	0.078	0.114	7.0547E-04	161.21	5.7471E-03	9.56	3.34E-04	-1.14E-04	5.78E-04	-1.97E-04	5.67E-03	9.55E-04
24												
-0.135	0.078	0.000	5.8010E-04	165.31	5.3713E-03	-33.03	2.81E-04	-7.36E-05	4.86E-04	-1.27E-04	4.50E-03	-2.93E-03
25												
-0.135	0.078	-0.114	6.9553E-04	166.61	4.2600E-03	-58.97	3.38E-04	-8.05E-05	5.86E-04	-1.39E-04	2.20E-03	-3.65E-03
26												
-0.054	0.093	0.171	1.5569E-02	-109.02	1.4146E-03	-176.68	3.76E-03	7.43E-03	-3.69E-03	-1.27E-02	0.00E+00	0.00E+00
27												
-0.054	0.093	-0.171	1.7610E-03	-92.01	1.4057E-03	3.00	1.25E-03	9.44E-04	6.48E-04	-1.49E-03	0.00E+00	0.00E+00
28												
-0.155	0.000	0.114	5.3352E-13	-103.74	5.2707E-03	-3.82	-5.20E-23	-2.13E-22	1.27E-13	5.18E-13	5.26E-03	-3.51E-04
29												
-0.155	0.000	0.000	4.1854E-13	-125.08	5.3698E-03	-33.05	-9.87E-23	-1.40E-22	2.41E-13	3.43E-13	4.50E-03	-2.93E-03
30												
-0.155	0.000	-0.114	1.1581E-13	-153.28	4.0751E-03	-57.88	-4.24E-23	-2.14E-23	1.03E-13	5.21E-14	2.17E-03	-3.45E-03
31												
-0.135	-0.078	0.114	7.0547E-04	-18.79	5.7471E-03	9.56	3.34E-04	-1.14E-04	-5.78E-04	1.97E-04	5.67E-03	9.55E-04
32												
-0.135	-0.078	0.000	5.8010E-04	-14.69	5.3713E-03	-33.03	2.81E-04	-7.36E-05	-4.86E-04	1.27E-04	4.50E-03	-2.93E-03
33												
-0.135	-0.078	-0.114	6.9553E-04	-13.39	4.2600E-03	-58.97	3.38E-04	-8.05E-05	-5.86E-04	1.39E-04	2.20E-03	-3.65E-03
34												
-0.107	0.000	0.171	1.5556E-02	-111.31	3.9163E-13	-73.46	5.65E-03	1.45E-02	2.21E-12	6.32E-12	0.00E+00	0.00E+00
35												
-0.107	0.000	-0.171	1.6722E-03	-112.54	2.2806E-13	-54.58	6.41E-04	1.54E-03	3.95E-13	4.48E-13	0.00E+00	0.00E+00
36												
-0.078	-0.135	0.114	1.3171E-03	1.33	5.0407E-03	-2.54	1.14E-03	2.65E-05	-6.58E-04	-1.53E-05	5.04E-03	-2.24E-04
37												
-0.078	-0.135	0.000	9.9513E-04	-1.35	5.3741E-03	-33.13	8.62E-04	-2.04E-05	-4.97E-04	1.18E-05	4.50E-03	-2.94E-03
38												
-0.078	-0.135	-0.114	1.3021E-03	-1.37	4.3368E-03	-56.63	1.13E-03	-2.69E-05	-6.51E-04	1.56E-05	2.39E-03	-3.62E-03
39												
0.000	-0.155	0.114	1.4453E-03	19.67	5.3230E-03	11.87	1.36E-03	4.86E-04	7.47E-13	2.67E-13	5.21E-03	1.09E-03
40												
0.000	-0.155	0.000	1.2076E-03	24.53	5.3687E-03	-32.95	1.10E-03	5.01E-04	6.03E-13	2.75E-13	4.51E-03	-2.92E-03
41												
0.000	-0.155	-0.114	1.4418E-03	19.75	4.6029E-03	-54.61	1.36E-03	4.87E-04	7.45E-13	2.67E-13	2.67E-03	-3.75E-03
42												
-0.054	-0.093	0.171	1.5569E-02	-109.02	1.4146E-03	3.32	3.76E-03	7.43E-03	3.69E-03	1.27E-02	0.00E+00	0.00E+00
43												
-0.054	-0.093	-0.171	1.7610E-03	-92.01	1.4057E-03	-177.00	1.25E-03	9.44E-04	-6.48E-04	1.49E-03	0.00E+00	0.00E+00
44												
0.078	-0.135	0.114	1.6708E-03	50.20	4.7412E-03	-8.86	9.26E-04	1.11E-03	5.35E-04	6.42E-04	4.68E-03	-7.30E-04
45												
0.078	-0.135	0.000	1.6297E-03	67.17	5.3696E-03	-33.12	5.48E-04	1.30E-03	3.16E-04	7.51E-04	4.50E-03	-2.93E-03
46												
0.078	-0.135	-0.114	1.7229E-03	51.43	4.1502E-03	-48.62	9.30E-04	1.17E-03	5.37E-04	6.74E-04	2.74E-03	-3.11E-03
47												

0.135	-0.078	0.114	1.8796E-03	85.14	5.5431E-03	-11.30	7.96E-05	9.36E-04	1.38E-04	1.62E-03	5.44E-03	-1.09E-03
48												
0.135	-0.078	0.000	3.9155E-03	104.52	5.3136E-03	-33.00	-4.91E-04	1.90E-03	-8.50E-04	3.28E-03	4.46E-03	-2.89E-03
49												
0.135	-0.078	-0.114	1.8136E-03	85.41	2.9175E-03	-33.42	7.26E-05	9.04E-04	1.26E-04	1.57E-03	2.44E-03	-1.61E-03
50												
0.054	-0.093	0.171	1.4844E-02	-105.23	1.6079E-03	34.37	-8.01E-04	-6.38E-03	4.04E-03	1.29E-02	0.00E+00	0.00E+00
51												
0.054	-0.093	-0.171	1.7546E-03	-50.90	1.6066E-03	-144.97	1.69E-03	1.18E-04	-3.00E-04	1.64E-03	0.00E+00	0.00E+00
52												
0.026	0.026	0.171	3.7705E-02	-97.61	3.8521E-02	-99.40	-4.99E-03	-3.74E-02	-6.29E-03	-3.80E-02	0.00E+00	0.00E+00
53												
-0.026	0.026	0.171	3.8970E-02	78.78	3.8495E-02	-99.34	7.58E-03	3.82E-02	-6.25E-03	-3.80E-02	0.00E+00	0.00E+00
54												
-0.026	-0.026	0.171	3.8970E-02	78.78	3.8495E-02	80.66	7.58E-03	3.82E-02	6.25E-03	3.80E-02	0.00E+00	0.00E+00
55												
0.026	-0.026	0.171	3.7705E-02	-97.61	3.8521E-02	80.60	-4.99E-03	-3.74E-02	6.29E-03	3.80E-02	0.00E+00	0.00E+00
56												
0.000	0.000	-0.171	1.3525E-03	18.01	6.6810E-13	177.16	1.29E-03	4.18E-04	6.67E-13	-3.31E-14	0.00E+00	0.00E+00

--- POWER BUDGET ---

INPUT POWER = 6.2562E-04 WATTS
 RADIATED POWER= 6.2562E-04 WATTS
 WIRE LOSS = 0.0000E+00 WATTS
 EFFICIENCY = 100.00 PERCENT

--- RADIATION PATTERNS ---

-- ANGLES --		- POWER GAINS -			--- POLARIZATION ---			--- E(THETA) ---		--- E(PHI) ---	
THETA	PHI	VERT.	HOR.	TOTAL	AXIAL	TILT	SENSE	MAGNITUDE	PHASE	MAGNITUDE	PHASE
DEGREES	DEGREES	DB	DB	DB	RATIO	DEG.		VOLTS	DEGREES	VOLTS	DEGREES
0.00	0.00	-8.10	-199.61	-8.10	0.00000	0.00	LINEAR	7.61801E-02	-2.25	2.02639E-11	2.67
5.00	0.00	-8.34	-199.91	-8.34	0.00000	0.00	LINEAR	7.41702E-02	-2.07	1.95677E-11	6.76
10.00	0.00	-8.85	-999.99	-8.85	0.00000	0.00	LINEAR	6.99567E-02	-2.75	1.89871E-11	10.57
15.00	0.00	-9.70	-999.99	-9.70	0.00000	0.00	LINEAR	6.33793E-02	-4.61	1.85114E-11	14.02
20.00	0.00	-11.01	-999.99	-11.01	0.00000	0.00	LINEAR	5.44954E-02	-8.23	1.81301E-11	17.07
25.00	0.00	-12.94	-999.99	-12.94	0.00000	0.00	LINEAR	4.36377E-02	-14.76	1.78335E-11	19.67
30.00	0.00	-15.74	-999.99	-15.74	0.00000	0.00	LINEAR	3.16388E-02	-27.31	1.76129E-11	21.79
35.00	0.00	-19.30	-999.99	-19.30	0.00000	0.00	LINEAR	2.09862E-02	-55.32	1.74614E-11	23.39
40.00	0.00	-19.98	-999.99	-19.98	0.00000	0.00	LINEAR	1.94197E-02	-107.80	1.73736E-11	24.47
45.00	0.00	-16.08	-999.99	-16.08	0.00000	0.00	LINEAR	3.04180E-02	-145.30	1.73453E-11	25.02
50.00	0.00	-12.40	-999.99	-12.40	0.00000	0.00	LINEAR	4.64493E-02	-163.88	1.73736E-11	25.02
55.00	0.00	-9.60	-999.99	-9.60	0.00000	0.00	LINEAR	6.41571E-02	-175.94	1.74570E-11	24.47
60.00	0.00	-7.40	-999.99	-7.40	0.00000	0.00	LINEAR	8.26337E-02	174.32	1.75953E-11	23.39
65.00	0.00	-5.61	-999.99	-5.61	0.00000	0.00	LINEAR	1.01577E-01	165.51	1.77896E-11	21.79
70.00	0.00	-4.10	-999.99	-4.10	0.00000	0.00	LINEAR	1.20848E-01	157.18	1.80424E-11	19.69
75.00	0.00	-2.80	-999.99	-2.80	0.00000	0.00	LINEAR	1.40308E-01	149.15	1.83574E-11	17.12
80.00	0.00	-1.67	-999.99	-1.67	0.00000	0.00	LINEAR	1.59730E-01	141.42	1.87394E-11	14.13
85.00	0.00	-0.70	-999.99	-0.70	0.00000	0.00	LINEAR	1.78749E-01	133.99	1.91931E-11	10.78
90.00	0.00	0.14	-199.84	0.14	0.00000	0.00	LINEAR	1.96860E-01	126.92	1.97225E-11	7.13
95.00	0.00	0.84	-199.58	0.84	0.00000	0.00	LINEAR	2.13435E-01	120.23	2.03303E-11	3.25
100.00	0.00	1.41	-199.29	1.41	0.00000	0.00	LINEAR	2.27775E-01	113.95	2.10158E-11	-0.78
105.00	0.00	1.83	-198.98	1.83	0.00000	0.00	LINEAR	2.39165E-01	108.08	2.17754E-11	-4.88
110.00	0.00	2.11	-198.66	2.11	0.00000	0.00	LINEAR	2.46942E-01	102.64	2.26015E-11	-8.98
115.00	0.00	2.24	-198.33	2.24	0.00000	0.00	LINEAR	2.50545E-01	97.66	2.34830E-11	-13.03
120.00	0.00	2.20	-197.99	2.20	0.00000	0.00	LINEAR	2.49562E-01	93.15	2.44063E-11	-16.97
125.00	0.00	2.00	-197.66	2.00	0.00000	0.00	LINEAR	2.43771E-01	89.16	2.53565E-11	-20.77
130.00	0.00	1.61	-197.34	1.61	0.00000	0.00	LINEAR	2.33153E-01	85.74	2.63186E-11	-24.41
135.00	0.00	1.02	-197.03	1.02	0.00000	0.00	LINEAR	2.17914E-01	82.99	2.72790E-11	-27.86
140.00	0.00	0.21	-196.73	0.21	0.00000	0.00	LINEAR	1.98485E-01	81.07	2.82266E-11	-31.12
145.00	0.00	-0.85	-196.45	-0.85	0.00000	0.00	LINEAR	1.75532E-01	80.23	2.91537E-11	-34.20
150.00	0.00	-2.22	-196.18	-2.22	0.00000	0.00	LINEAR	1.49982E-01	80.93	3.00564E-11	-37.08
155.00	0.00	-3.94	-195.93	-3.94	0.00000	0.00	LINEAR	1.23113E-01	83.98	3.09345E-11	-39.79
160.00	0.00	-6.02	-195.70	-6.02	0.00000	0.00	LINEAR	9.68058E-02	90.96	3.17908E-11	-42.31
165.00	0.00	-8.33	-195.47	-8.33	0.00000	0.00	LINEAR	7.42434E-02	104.78	3.26308E-11	-44.67
170.00	0.00	-10.04	-195.25	-10.04	0.00000	0.00	LINEAR	6.09833E-02	128.43	3.34614E-11	-46.87
175.00	0.00	-9.83	-195.04	-9.83	0.00000	0.00	LINEAR	6.24556E-02	156.55	3.42901E-11	-48.91
180.00	0.00	-8.13	-194.83	-8.13	0.00000	0.00	LINEAR	7.59667E-02	177.78	3.51234E-11	-50.80
185.00	0.00	-6.24	-194.62	-6.24	0.00000	0.00	LINEAR	9.44016E-02	-168.89	3.59665E-11	-52.55
190.00	0.00	-4.65	-194.42	-4.65	0.00000	0.00	LINEAR	1.13367E-01	-159.93	3.68220E-11	-54.14
195.00	0.00	-3.40	-194.22	-3.40	0.00000	0.00	LINEAR	1.30945E-01	-152.98	3.76896E-11	-55.60
200.00	0.00	-2.43	-194.02	-2.43	0.00000	0.00	LINEAR	1.46423E-01	-146.81	3.85654E-11	-56.91
205.00	0.00	-1.68	-193.82	-1.68	0.00000	0.00	LINEAR	1.59690E-01	-140.78	3.94423E-11	-58.07
210.00	0.00	-1.08	-193.63	-1.08	0.00000	0.00	LINEAR	1.70963E-01	-134.57	4.03098E-11	-59.09
215.00	0.00	-0.61	-193.45	-0.61	0.00000	0.00	LINEAR	1.80618E-01	-128.06	4.11542E-11	-59.95

220.00	0.00	-0.21	-193.28	-0.21	0.00000	0.00	LINEAR	1.89045E-01	-121.23	4.19595E-11	-60.66
225.00	0.00	0.13	-193.13	0.13	0.00000	0.00	LINEAR	1.96534E-01	-114.15	4.27076E-11	-61.20
230.00	0.00	0.42	-193.00	0.42	0.00000	0.00	LINEAR	2.03196E-01	-106.93	4.33790E-11	-61.57
235.00	0.00	0.66	-192.88	0.66	0.00000	0.00	LINEAR	2.08937E-01	-99.67	4.39540E-11	-61.76
240.00	0.00	0.85	-192.79	0.85	0.00000	0.00	LINEAR	2.13486E-01	-92.48	4.44126E-11	-61.77
245.00	0.00	0.97	-192.73	0.97	0.00000	0.00	LINEAR	2.16462E-01	-85.43	4.47363E-11	-61.58
250.00	0.00	1.01	-192.70	1.01	0.00000	0.00	LINEAR	2.17459E-01	-78.55	4.49078E-11	-61.19
255.00	0.00	0.95	-192.69	0.95	0.00000	0.00	LINEAR	2.16129E-01	-71.88	4.49124E-11	-60.59
260.00	0.00	0.79	-192.73	0.79	0.00000	0.00	LINEAR	2.12241E-01	-65.42	4.47386E-11	-59.79
265.00	0.00	0.52	-192.80	0.52	0.00000	0.00	LINEAR	2.05723E-01	-59.16	4.43782E-11	-58.76
270.00	0.00	0.13	-192.91	0.13	0.00000	0.00	LINEAR	1.96679E-01	-53.13	4.38274E-11	-57.51
275.00	0.00	-0.38	-193.05	-0.38	0.00000	0.00	LINEAR	1.85389E-01	-47.32	4.30868E-11	-56.02
280.00	0.00	-1.02	-193.24	-1.02	0.00000	0.00	LINEAR	1.72283E-01	-41.75	4.21621E-11	-54.31
285.00	0.00	-1.77	-193.47	-1.77	0.00000	0.00	LINEAR	1.57917E-01	-36.46	4.10637E-11	-52.35
290.00	0.00	-2.64	-193.74	-2.64	0.00000	0.00	LINEAR	1.42931E-01	-31.49	3.98071E-11	-50.16
295.00	0.00	-3.60	-194.05	-3.60	0.00000	0.00	LINEAR	1.28004E-01	-26.90	3.84126E-11	-47.72
300.00	0.00	-4.62	-194.40	-4.62	0.00000	0.00	LINEAR	1.13805E-01	-22.79	3.69046E-11	-45.04
305.00	0.00	-5.66	-194.78	-5.66	0.00000	0.00	LINEAR	1.00951E-01	-19.22	3.53112E-11	-42.10
310.00	0.00	-6.66	-195.20	-6.66	0.00000	0.00	LINEAR	8.99607E-02	-16.30	3.36629E-11	-38.92
315.00	0.00	-7.55	-195.64	-7.55	0.00000	0.00	LINEAR	8.12155E-02	-14.02	3.19917E-11	-35.48
320.00	0.00	-8.25	-196.10	-8.25	0.00000	0.00	LINEAR	7.49200E-02	-12.32	3.03300E-11	-31.81
325.00	0.00	-8.71	-196.58	-8.71	0.00000	0.00	LINEAR	7.10725E-02	-11.01	2.87086E-11	-27.91
330.00	0.00	-8.91	-197.06	-8.91	0.00000	0.00	LINEAR	6.94549E-02	-9.84	2.71558E-11	-23.80
335.00	0.00	-8.88	-197.54	-8.88	0.00000	0.00	LINEAR	6.96525E-02	-8.59	2.56960E-11	-19.52
340.00	0.00	-8.70	-198.01	-8.70	0.00000	0.00	LINEAR	7.11031E-02	-7.20	2.43484E-11	-15.10
345.00	0.00	-8.46	-198.46	-8.46	0.00000	0.00	LINEAR	7.31546E-02	-5.71	2.31266E-11	-10.60
350.00	0.00	-8.23	-198.88	-8.23	0.00000	0.00	LINEAR	7.51209E-02	-4.26	2.20383E-11	-6.09
355.00	0.00	-8.09	-199.26	-8.09	0.00000	0.00	LINEAR	7.63315E-02	-3.05	2.10851E-11	-1.64
360.00	0.00	-8.10	-199.61	-8.10	0.00000	0.00	LINEAR	7.61801E-02	-2.25	2.02639E-11	2.67

***** INPUT LINE 5 EX 0 2 1 0 1.00000E+00 0.00000E+00 0.00000E+00 0.00000E+00 0.00000E+00 0.00000E+00
 ***** INPUT LINE 6 XQ 0 0 0 0 0.00000E+00 0.00000E+00 0.00000E+00 0.00000E+00 0.00000E+00 0.00000E+00

- - - ANTENNA INPUT PARAMETERS - - -

TAG NO.	SEG. NO.	VOLTAGE (VOLTS)		CURRENT (AMPS)		IMPEDANCE (OHMS)		ADMITTANCE (MHOS)		POWER (WATTS)
		REAL	IMAG.	REAL	IMAG.	REAL	IMAG.	REAL	IMAG.	
2	5	1.00000E+00	0.00000E+00	1.50288E-02	-6.91204E-03	5.49216E+01	2.52595E+01	1.50288E-02	-6.91204E-03	7.51439E-03

- - - CURRENTS AND LOCATION - - -

LENGTHS NORMALIZED BY WAVELENGTH (OR 2.*PI/CABS(K))

SEG. NO.	TAG NO.	COORD. OF SEG. CENTER			SEG. LENGTH	CURRENT (AMPS) - - -			
		X	Y	Z		REAL	IMAG.	MAG.	PHASE
1	1	0.0000	0.0000	0.1942	0.04662	-9.0580E-04	1.7154E-03	1.9399E-03	117.836
2	1	0.0000	0.0000	0.2408	0.04662	-7.8794E-04	1.5064E-03	1.7000E-03	117.613
3	1	0.0000	0.0000	0.2875	0.04662	-5.5915E-04	1.0891E-03	1.2242E-03	117.177
4	1	0.0000	0.0000	0.3341	0.04662	-2.2834E-04	4.5624E-04	5.1019E-04	116.587
5	2	0.1827	0.0000	0.0000	0.05470	1.5029E-02	-6.9120E-03	1.6542E-02	-24.699
6	2	0.2374	0.0000	0.0000	0.05470	1.3802E-02	-7.4032E-03	1.5662E-02	-28.208
7	2	0.2921	0.0000	0.0000	0.05470	1.1403E-02	-6.7791E-03	1.3266E-02	-30.731
8	2	0.3468	0.0000	0.0000	0.05470	7.8898E-03	-5.0203E-03	9.3516E-03	-32.469
9	2	0.4015	0.0000	0.0000	0.05470	3.2561E-03	-2.1808E-03	3.9190E-03	-33.813

- - - SURFACE PATCH CURRENTS - - -

DISTANCES IN WAVELENGTHS (2.*PI/CABS(K))
 CURRENT IN AMPS/METER

- - SURFACE COMPONENTS - -						- - - RECTANGULAR COMPONENTS - - -							
PATCH	CENTER			TANGENT VECTOR 1		TANGENT VECTOR 2		X	Y	Z			
	X	Y	Z	MAG.	PHASE	MAG.	PHASE				REAL	IMAG.	REAL
1	0.155	0.000	0.114	2.5778E-12	-142.34	4.0395E-02	140.23	0.00E+00	0.00E+00	-2.04E-12	-1.58E-12	-3.10E-02	2.58E-02
2	0.155	0.024	0.024	8.6326E-02	153.30	8.8861E-02	153.00	0.00E+00	0.00E+00	-7.71E-02	3.88E-02	-7.92E-02	4.03E-02

0.155	-0.024	0.024	8.6326E-02	-26.70	8.8861E-02	153.00	0.00E+00	0.00E+00	7.71E-02	-3.88E-02	-7.92E-02	4.03E-02
4												
0.155	-0.024	-0.024	8.6323E-02	-26.70	9.1298E-02	-26.15	0.00E+00	0.00E+00	7.71E-02	-3.88E-02	8.20E-02	-4.02E-02
5												
0.155	0.024	-0.024	8.6323E-02	153.30	9.1298E-02	-26.15	0.00E+00	0.00E+00	-7.71E-02	3.88E-02	8.20E-02	-4.02E-02
6												
0.155	0.000	-0.114	2.6972E-12	-130.94	4.1818E-02	-37.69	0.00E+00	0.00E+00	-1.77E-12	-2.04E-12	3.31E-02	-2.56E-02
7												
0.135	0.078	0.114	1.7535E-02	121.84	2.2203E-02	129.66	4.63E-03	-7.45E-03	-8.01E-03	1.29E-02	-1.42E-02	1.71E-02
8												
0.135	0.078	0.000	3.7645E-02	141.93	1.3238E-03	2.36	1.48E-02	-1.16E-02	-2.57E-02	2.01E-02	1.32E-03	5.45E-05
9												
0.135	0.078	-0.114	1.7518E-02	121.84	2.3099E-02	-45.70	4.62E-03	-7.44E-03	-8.00E-03	1.29E-02	1.61E-02	-1.65E-02
10												
0.107	0.000	0.171	2.0215E-02	-85.04	1.3924E-11	-60.61	1.75E-03	-2.01E-02	6.83E-12	-1.21E-11	0.00E+00	0.00E+00
11												
0.107	0.000	-0.171	1.6876E-02	-87.10	1.4406E-11	121.31	8.55E-04	-1.69E-02	7.49E-12	-1.23E-11	0.00E+00	0.00E+00
12												
0.078	0.135	0.114	1.6712E-02	87.53	6.2231E-03	106.05	-6.25E-04	-1.45E-02	3.61E-04	8.35E-03	-1.72E-03	5.98E-03
13												
0.078	0.135	0.000	1.5769E-02	103.51	1.3329E-03	2.81	3.19E-03	-1.33E-02	-1.84E-03	7.67E-03	1.33E-03	6.54E-05
14												
0.078	0.135	-0.114	1.6655E-02	87.45	6.8125E-03	-56.49	-6.41E-04	-1.44E-02	3.70E-04	8.32E-03	3.76E-03	-5.68E-03
15												
0.000	0.155	0.114	1.3966E-02	55.65	1.7992E-03	89.82	-7.88E-03	-1.15E-02	-1.09E-12	-1.60E-12	5.58E-06	1.80E-03
16												
0.000	0.155	0.000	1.1671E-02	60.49	1.3311E-03	3.42	-5.75E-03	-1.02E-02	-7.96E-13	-1.41E-12	1.33E-03	7.94E-05
17												
0.000	0.155	-0.114	1.3952E-02	55.63	2.2809E-03	-30.99	-7.88E-03	-1.15E-02	-1.09E-12	-1.59E-12	1.96E-03	-1.17E-03
18												
0.054	0.093	0.171	9.5487E-03	-98.10	1.5575E-02	70.79	-5.11E-03	-1.75E-02	1.40E-03	-8.33E-04	0.00E+00	0.00E+00
19												
0.054	0.093	-0.171	6.5737E-03	-109.89	1.5544E-02	-109.23	-5.55E-03	-1.58E-02	6.23E-04	1.98E-03	0.00E+00	0.00E+00
20												
-0.078	0.135	0.114	1.2624E-02	34.29	1.5700E-03	179.33	-9.03E-03	-6.16E-03	-5.22E-03	-3.56E-03	-1.57E-03	1.83E-05
21												
-0.078	0.135	0.000	9.6173E-03	34.26	1.3373E-03	3.29	-6.88E-03	-4.69E-03	-3.97E-03	-2.71E-03	1.34E-03	7.67E-05
22												
-0.078	0.135	-0.114	1.2603E-02	34.43	3.6445E-03	5.06	-9.00E-03	-6.17E-03	-5.20E-03	-3.56E-03	3.63E-03	3.21E-04
23												
-0.135	0.078	0.114	6.7440E-03	22.43	4.2070E-03	-179.28	-3.12E-03	-1.29E-03	-5.40E-03	-2.23E-03	-4.21E-03	-5.26E-05
24												
-0.135	0.078	0.000	5.6066E-03	21.57	1.3442E-03	3.21	-2.61E-03	-1.03E-03	-4.52E-03	-1.78E-03	1.34E-03	7.53E-05
25												
-0.135	0.078	-0.114	6.7311E-03	22.45	6.2421E-03	6.28	-3.11E-03	-1.29E-03	-5.39E-03	-2.23E-03	6.20E-03	6.82E-04
26												
-0.054	0.093	0.171	5.5928E-03	3.16	1.3636E-02	38.75	-1.20E-02	-7.54E-03	-4.81E-04	-4.00E-03	0.00E+00	0.00E+00
27												
-0.054	0.093	-0.171	5.8828E-03	37.28	1.3611E-02	-141.23	-1.15E-02	-9.16E-03	-1.25E-03	-1.18E-03	0.00E+00	0.00E+00
28												
-0.155	0.000	0.114	3.2232E-12	143.28	4.2246E-03	178.49	-1.06E-21	7.90E-22	2.58E-12	-1.93E-12	-4.22E-03	1.11E-04
29												
-0.155	0.000	0.000	4.1153E-12	115.22	1.3472E-03	3.06	-7.19E-22	1.53E-21	1.75E-12	-3.72E-12	1.35E-03	7.19E-05
30												
-0.155	0.000	-0.114	3.3319E-12	142.78	6.3070E-03	2.14	-1.09E-21	8.27E-22	2.65E-12	-2.02E-12	6.30E-03	2.35E-04
31												
-0.135	-0.078	0.114	6.7440E-03	-157.57	4.2070E-03	-179.28	-3.12E-03	-1.29E-03	5.40E-03	2.23E-03	-4.21E-03	-5.26E-05
32												
-0.135	-0.078	0.000	5.6066E-03	-158.43	1.3442E-03	3.21	-2.61E-03	-1.03E-03	4.52E-03	1.78E-03	1.34E-03	7.53E-05
33												
-0.135	-0.078	-0.114	6.7311E-03	-157.55	6.2421E-03	6.28	-3.11E-03	-1.29E-03	5.39E-03	2.23E-03	6.20E-03	6.82E-04
34												
-0.107	0.000	0.171	1.1521E-02	9.49	3.0311E-12	159.13	-1.14E-02	-1.90E-03	-1.83E-12	-1.86E-12	0.00E+00	0.00E+00
35												
-0.107	0.000	-0.171	1.1649E-02	26.25	3.1768E-12	-21.28	-1.04E-02	-5.15E-03	-1.33E-12	-3.27E-12	0.00E+00	0.00E+00
36												
-0.078	-0.135	0.114	1.2624E-02	-145.71	1.5700E-03	179.33	-9.03E-03	-6.16E-03	5.22E-03	3.56E-03	-1.57E-03	1.83E-05
37												
-0.078	-0.135	0.000	9.6173E-03	-145.74	1.3373E-03	3.29	-6.88E-03	-4.69E-03	3.97E-03	2.71E-03	1.34E-03	7.67E-05
38												
-0.078	-0.135	-0.114	1.2603E-02	-145.57	3.6445E-03	5.06	-9.00E-03	-6.17E-03	5.20E-03	3.56E-03	3.63E-03	3.21E-04
39												
0.000	-0.155	0.114	1.3966E-02	-124.35	1.7992E-03	89.82	-7.88E-03	-1.15E-02	-4.32E-12	-6.33E-12	5.58E-06	1.80E-03
40												
0.000	-0.155	0.000	1.1671E-02	-119.51	1.3311E-03	3.42	-5.75E-03	-1.02E-02	-3.15E-12	-5.57E-12	1.33E-03	7.94E-05
41												
0.000	-0.155	-0.114	1.3952E-02	-124.37	2.2809E-03	-30.99	-7.88E-03	-1.15E-02	-4.32E-12	-6.32E-12	1.96E-03	-1.17E-03
42												
-0.054	-0.093	0.171	5.5928E-03	3.16	1.3636E-02	-141.25	-1.20E-02	-7.54E-03	4.81E-04	4.00E-03	0.00E+00	0.00E+00
43												

-0.054	-0.093	-0.171	5.8828E-03	37.28	1.3611E-02	38.77	-1.15E-02	-9.16E-03	1.25E-03	1.18E-03	0.00E+00	0.00E+00	
44	0.078	-0.135	0.114	1.6712E-02	-92.47	6.2231E-03	106.05	-6.25E-04	-1.45E-02	-3.61E-04	-8.35E-03	-1.72E-03	5.98E-03
45	0.078	-0.135	0.000	1.5769E-02	-76.49	1.3329E-03	2.81	3.19E-03	-1.33E-02	1.84E-03	-7.67E-03	1.33E-03	6.54E-05
46	0.078	-0.135	-0.114	1.6655E-02	-92.55	6.8125E-03	-56.49	-6.41E-04	-1.44E-02	-3.70E-04	-8.32E-03	3.76E-03	-5.68E-03
47	0.135	-0.078	0.114	1.7535E-02	-58.16	2.2203E-02	129.66	4.63E-03	-7.45E-03	8.01E-03	-1.29E-02	-1.42E-02	1.71E-02
48	0.135	-0.078	0.000	3.7645E-02	-38.07	1.3238E-03	2.36	1.48E-02	-1.16E-02	2.57E-02	-2.01E-02	1.32E-03	5.45E-05
49	0.135	-0.078	-0.114	1.7518E-02	-58.16	2.3099E-02	-45.70	4.62E-03	-7.44E-03	8.00E-03	-1.29E-02	1.61E-02	-1.65E-02
50	0.054	-0.093	0.171	9.5487E-03	-98.10	1.5575E-02	-109.21	-5.11E-03	-1.75E-02	-1.40E-03	8.33E-04	0.00E+00	0.00E+00
51	0.054	-0.093	-0.171	6.5737E-03	-109.89	1.5544E-02	70.77	-5.55E-03	-1.58E-02	-6.23E-04	-1.98E-03	0.00E+00	0.00E+00
52	0.026	0.026	0.171	2.0113E-02	-97.13	8.6908E-03	-62.32	-2.50E-03	-2.00E-02	4.04E-03	-7.70E-03	0.00E+00	0.00E+00
53	-0.026	0.026	0.171	1.2975E-02	-174.04	8.9451E-03	-64.50	-1.29E-02	-1.35E-03	3.85E-03	-8.07E-03	0.00E+00	0.00E+00
54	-0.026	-0.026	0.171	1.2975E-02	-174.04	8.9451E-03	115.50	-1.29E-02	-1.35E-03	-3.85E-03	8.07E-03	0.00E+00	0.00E+00
55	0.026	-0.026	0.171	2.0113E-02	-97.13	8.6908E-03	117.68	-2.50E-03	-2.00E-02	-4.04E-03	7.70E-03	0.00E+00	0.00E+00
56	0.000	0.000	-0.171	1.3089E-02	-126.30	4.7383E-12	85.36	-7.75E-03	-1.05E-02	-3.83E-13	-4.72E-12	0.00E+00	0.00E+00

- - - POWER BUDGET - - -

INPUT POWER = 7.5144E-03 WATTS
 RADIATED POWER = 7.5144E-03 WATTS
 WIRE LOSS = 0.0000E+00 WATTS
 EFFICIENCY = 100.00 PERCENT

***** INPUT LINE 7 EN 0 0 0 0 0.00000E+00 0.00000E+00 0.00000E+00 0.00000E+00 0.00000E+00 0.00000E+00

RUN TIME = 0.510

4.2.4 Examples 7 and 8, Scattering by a Wire and Aircraft

Examples 7 and 8 demonstrate the use of NEC for scattering calculations. The normalized cross sections (σ/λ^2) for bistatic scattering are printed in the radiation-pattern tables. Example 8 is a stick-model of an aircraft, as shown in figure 23.

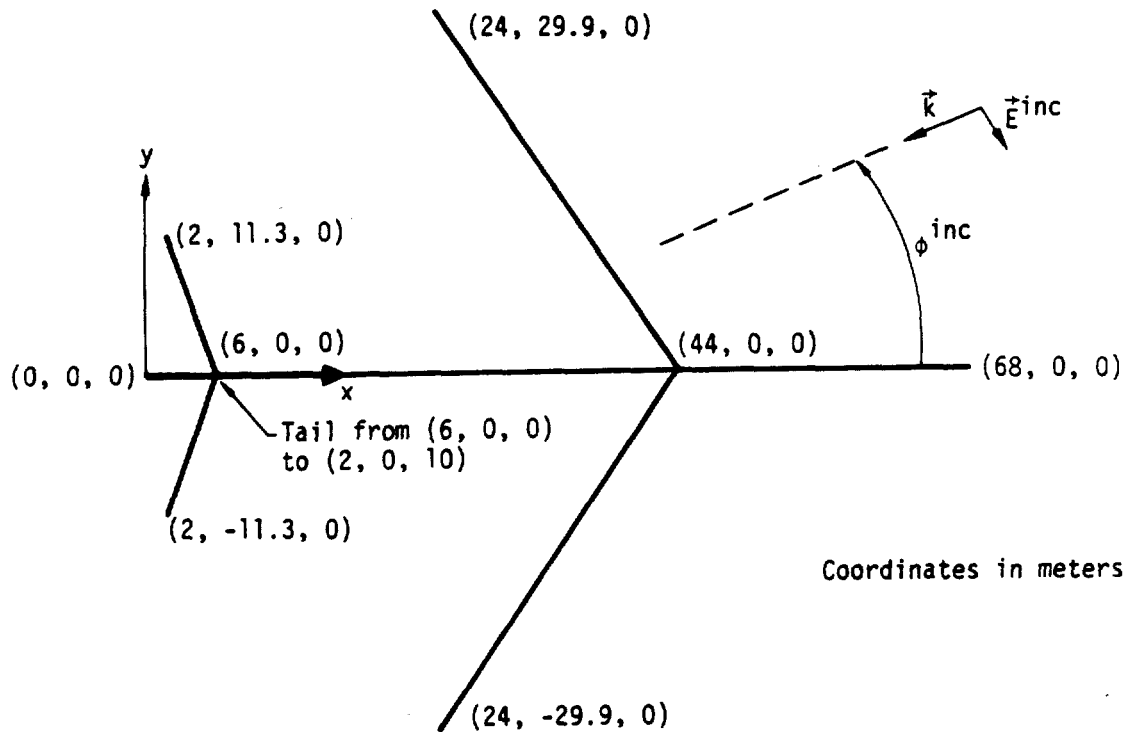

Fig. 23. Stick model of an aircraft.

Input for Examples 7 and 8

CMSAMPLE PROBLEMS FOR NEC - SCATTERING BY A WIRE.

```

CM 1. STRAIGHT WIRE - FREE SPACE
CM 2. STRAIGHT WIRE - PERFECT GROUND
CM 3. STRAIGHT WIRE - FINITELY CONDUCTING GROUND
CE (SIG.=1.E-4 MHOS/M., EPS.=6.)
GW 0 15 -55. 0. 10. 55. 0. 10. .01
GE 1
FR 0 1 0 0 3.
EX 1 2 1 0 0. 0. 0. 45. 0.
RP 0 2 1 1000 0. 0. 45. 0.
GN 1
EX 1 1 1 0 45. 0. 0.
RP 0 19 1 1000 90. 0. -10. 0.
GN 0 0 0 0 6. 1.000E-04
RP 0 19 1 1000 90. 0. -10. 0.
NK

```

CMSAMPLE PROBLEM FOR NEC

CESTICK MODEL OF AIRCRAFT - FREE SPACE

```

GW 1 1 0. 0. 0. 6. 0. 0. 1.
GW 2 6 6. 0. 0. 44. 0. 0. 1.
GW 3 4 44. 0. 0. 68. 0. 0. 1.
GW 4 6 44. 0. 0. 24. 29.9 0. 1.
GW 5 6 44. 0. 0. 24. -29.9 0. 1.
GW 6 2 6. 0. 0. 2. 11.3 0. 1.
GW 7 2 6. 0. 0. 2. -11.3 0. 1.
GW 8 2 6. 0. 0. 2. 0. 10. 1.
GE
FR 0 1 0 0 3.
EX 1 1 1 0 0. 0. 0.
RP 0 1 1 1000 0. 0. 0.
EX 1 1 1 0 90. 30. -90.
RP 0 1 1 1000 90. 30.
EN

```

Output for Examples 7 and 8

```

*****
*
* NUMERICAL ELECTROMAGNETICS CODE (NEC-4.1) *
*
*****
    
```

```

*****
SAMPLE PROBLEMS FOR NEC - SCATTERING BY A WIRE.
1. STRAIGHT WIRE - FREE SPACE
2. STRAIGHT WIRE - PERFECT GROUND
3. STRAIGHT WIRE - FINITELY CONDUCTING GROUND
   (SIG.=1.E-4 MHOS/M., EPS.=6.)
*****
    
```

- - - STRUCTURE SPECIFICATION - - -

COORDINATES MUST BE INPUT IN
METERS OR BE SCALED TO METERS
BEFORE STRUCTURE INPUT IS ENDED

WIRE NO.	X1	Y1	Z1	X2	Y2	Z2	RADIUS	NO. OF SEG.	FIRST SEG.	LAST SEG.	TAG NO.
1	-55.00000	0.00000	10.00000	55.00000	0.00000	10.00000	0.01000	15	1	15	0

GROUND PLANE SPECIFIED.

WHERE WIRE ENDS TOUCH GROUND, CURRENT WILL BE INTERPOLATED TO IMAGE IN GROUND PLANE.

TOTAL SEGMENTS USED= 15 NO. SEG. IN A SYMMETRIC CELL= 15 SYMMETRY FLAG= 0

- MULTIPLE WIRE JUNCTIONS -

JUNCTION SEGMENTS (- FOR END 1, + FOR END 2)
NONE

- - - SEGMENTATION DATA - - -

COORDINATES IN METERS

I+ AND I- INDICATE THE SEGMENTS BEFORE AND AFTER I

SEG. NO.	COORDINATES OF SEG. CENTER			SEG. LENGTH	ORIENTATION ANGLES		WIRE RADIUS	CONNECTION DATA			TAG NO.
	X	Y	Z		ALPHA	BETA		I-	I	I+	
1	-51.33333	0.00000	10.00000	7.33333	0.00000	0.00000	0.01000	0	1	2	0
2	-44.00000	0.00000	10.00000	7.33333	0.00000	0.00000	0.01000	1	2	3	0
3	-36.66667	0.00000	10.00000	7.33333	0.00000	0.00000	0.01000	2	3	4	0
4	-29.33333	0.00000	10.00000	7.33333	0.00000	0.00000	0.01000	3	4	5	0
5	-22.00000	0.00000	10.00000	7.33333	0.00000	0.00000	0.01000	4	5	6	0
6	-14.66667	0.00000	10.00000	7.33333	0.00000	0.00000	0.01000	5	6	7	0
7	-7.33333	0.00000	10.00000	7.33333	0.00000	0.00000	0.01000	6	7	8	0
8	0.00000	0.00000	10.00000	7.33333	0.00000	0.00000	0.01000	7	8	9	0
9	7.33333	0.00000	10.00000	7.33333	0.00000	0.00000	0.01000	8	9	10	0
10	14.66667	0.00000	10.00000	7.33333	0.00000	0.00000	0.01000	9	10	11	0
11	22.00000	0.00000	10.00000	7.33333	0.00000	0.00000	0.01000	10	11	12	0
12	29.33333	0.00000	10.00000	7.33333	0.00000	0.00000	0.01000	11	12	13	0
13	36.66667	0.00000	10.00000	7.33333	0.00000	0.00000	0.01000	12	13	14	0
14	44.00000	0.00000	10.00000	7.33333	0.00000	0.00000	0.01000	13	14	15	0
15	51.33333	0.00000	10.00000	7.33333	0.00000	0.00000	0.01000	14	15	0	0

```

***** INPUT LINE 1 FR 0 1 0 0 3.00000E+00 0.00000E+00 0.00000E+00 0.00000E+00 0.00000E+00 0.00000E+00
***** INPUT LINE 2 EX 1 2 1 0 0.00000E+00 0.00000E+00 0.00000E+00 4.50000E+01 0.00000E+00 0.00000E+00
***** INPUT LINE 3 RP 0 2 1 1000 0.00000E+00 0.00000E+00 4.50000E+01 0.00000E+00 0.00000E+00 0.00000E+00

```

----- FREQUENCY -----

FREQUENCY= 3.0000E+00 MHZ
WAVELENGTH= 9.9933E+01 METERS

----- ANTENNA ENVIRONMENT -----

FREE SPACE

----- STRUCTURE IMPEDANCE LOADING -----

THIS STRUCTURE IS NOT LOADED

----- MATRIX TIMING -----

FILL= 0.020 SEC., FACTOR= 0.000 SEC.

----- EXCITATION -----

PLANE WAVE THETA= 0.00 DEG, PHI= 0.00 DEG, ETA= 0.00 DEG, TYPE -LINEAR= AXIAL RATIO= 0.000

----- CURRENTS AND LOCATION -----

LENGTHS NORMALIZED BY WAVELENGTH (OR 2.*PI/CABS(K))

SEG. NO.	TAG NO.	COORD. OF SEG. CENTER			SEG. LENGTH	CURRENT (AMPS)			PHASE
		X	Y	Z		REAL	IMAG.	MAG.	
1	0	-0.5137	0.0000	0.1001	0.07338	-8.8817E-04	2.5670E-03	2.7163E-03	109.085
2	0	-0.4403	0.0000	0.1001	0.07338	1.5985E-03	2.1975E-03	2.7174E-03	53.967
3	0	-0.3669	0.0000	0.1001	0.07338	8.8158E-03	-4.2494E-03	9.7865E-03	-25.735
4	0	-0.2935	0.0000	0.1001	0.07338	1.9216E-02	-1.4937E-02	2.4339E-02	-37.860
5	0	-0.2201	0.0000	0.1001	0.07338	3.0735E-02	-2.7408E-02	4.1181E-02	-41.726
6	0	-0.1468	0.0000	0.1001	0.07338	4.1101E-02	-3.8922E-02	5.6606E-02	-43.440
7	0	-0.0734	0.0000	0.1001	0.07338	4.8271E-02	-4.6991E-02	6.7367E-02	-44.230
8	0	0.0000	0.0000	0.1001	0.07338	5.0830E-02	-4.9887E-02	7.1221E-02	-44.464
9	0	0.0734	0.0000	0.1001	0.07338	4.8271E-02	-4.6991E-02	6.7367E-02	-44.230
10	0	0.1468	0.0000	0.1001	0.07338	4.1101E-02	-3.8922E-02	5.6606E-02	-43.440
11	0	0.2201	0.0000	0.1001	0.07338	3.0735E-02	-2.7408E-02	4.1181E-02	-41.726
12	0	0.2935	0.0000	0.1001	0.07338	1.9216E-02	-1.4937E-02	2.4339E-02	-37.860
13	0	0.3669	0.0000	0.1001	0.07338	8.8158E-03	-4.2494E-03	9.7865E-03	-25.735
14	0	0.4403	0.0000	0.1001	0.07338	1.5985E-03	2.1975E-03	2.7174E-03	53.967
15	0	0.5137	0.0000	0.1001	0.07338	-8.8817E-04	2.5670E-03	2.7163E-03	109.085

----- RADIATION PATTERNS -----

- - ANGLES - -		- CROSS SECTION -			- - - POLARIZATION - - -			- - - E(THETA) - - -		- - - E(PHI) - - -	
THETA DEGREES	PHI DEGREES	VERT. DB	HOR. DB	TOTAL DB	AXIAL RATIO	TILT DEG.	SENSE	MAGNITUDE VOLTS	PHASE DEGREES	MAGNITUDE VOLTS	PHASE DEGREES
0.00	0.00	-12.86	-999.99	-12.86	0.00000	0.00	LINEAR	6.41328E+00	-95.23	0.00000E+00	0.00
45.00	0.00	-18.33	-999.99	-18.33	0.00000	0.00	LINEAR	3.41557E+00	-108.66	0.00000E+00	0.00

----- EXCITATION -----

PLANE WAVE THETA= 45.00 DEG, PHI= 0.00 DEG, ETA= 0.00 DEG, TYPE -LINEAR= AXIAL RATIO= 0.000

- - - CURRENTS AND LOCATION - - -

LENGTHS NORMALIZED BY WAVELENGTH (OR 2.*PI/CABS(K))

SEG. NO.	TAG NO.	COORD. OF SEG. CENTER			SEG. LENGTH	CURRENT (AMPS)			PHASE
		X	Y	Z		REAL	IMAG.	MAG.	
1	0	-0.5137	0.0000	0.1001	0.07338	-1.4018E-02	-2.6706E-02	3.0161E-02	-117.696
2	0	-0.4403	0.0000	0.1001	0.07338	-3.9114E-02	-6.9420E-02	7.9681E-02	-119.399
3	0	-0.3669	0.0000	0.1001	0.07338	-5.8271E-02	-9.6998E-02	1.1316E-01	-120.995
4	0	-0.2935	0.0000	0.1001	0.07338	-6.7872E-02	-1.0687E-01	1.2660E-01	-122.420
5	0	-0.2201	0.0000	0.1001	0.07338	-6.5358E-02	-9.8633E-02	1.1832E-01	-123.530
6	0	-0.1468	0.0000	0.1001	0.07338	-5.0272E-02	-7.4959E-02	9.0256E-02	-123.848
7	0	-0.0734	0.0000	0.1001	0.07338	-2.4527E-02	-4.1065E-02	4.7832E-02	-120.849
8	0	0.0000	0.0000	0.1001	0.07338	7.8286E-03	-3.6793E-03	8.6501E-03	-25.173
9	0	0.0734	0.0000	0.1001	0.07338	4.1295E-02	3.0302E-02	5.1220E-02	36.271
10	0	0.1468	0.0000	0.1001	0.07338	6.9909E-02	5.5139E-02	8.9037E-02	38.264
11	0	0.2201	0.0000	0.1001	0.07338	8.8355E-02	6.7302E-02	1.1107E-01	37.297
12	0	0.2935	0.0000	0.1001	0.07338	9.2958E-02	6.6030E-02	1.1402E-01	35.387
13	0	0.3669	0.0000	0.1001	0.07338	8.2371E-02	5.3310E-02	9.8117E-02	32.910
14	0	0.4403	0.0000	0.1001	0.07338	5.7747E-02	3.3262E-02	6.6641E-02	29.942
15	0	0.5137	0.0000	0.1001	0.07338	2.1820E-02	1.0871E-02	2.4378E-02	26.483

- - - RADIATION PATTERNS - - -

- - ANGLES - -		- CROSS SECTION -			- - - POLARIZATION - - -			- - - E(THETA) - - -		- - - E(PHI) - - -	
THETA DEGREES	PHI DEGREES	VERT. DB	HOR. DB	TOTAL DB	AXIAL RATIO	TILT DEG.	SENSE	MAGNITUDE VOLTS	PHASE DEGREES	MAGNITUDE VOLTS	PHASE DEGREES
0.00	0.00	-18.38	-999.99	-18.38	0.00000	0.00	LINEAR	3.39889E+00	-108.66	0.00000E+00	0.00
45.00	0.00	-10.40	-999.99	-10.40	0.00000	0.00	LINEAR	8.51376E+00	71.99	0.00000E+00	0.00

***** INPUT LINE 4 GN 1 0 0 0 0.00000E+00 0.00000E+00 0.00000E+00 0.00000E+00 0.00000E+00 0.00000E+00
 ***** INPUT LINE 5 EX 1 1 1 0 4.50000E+01 0.00000E+00 0.00000E+00 0.00000E+00 0.00000E+00 0.00000E+00
 ***** INPUT LINE 6 RP 0 19 1 1000 9.00000E+01 0.00000E+00 -1.00000E+01 0.00000E+00 0.00000E+00 0.00000E+00

- - - - - FREQUENCY - - - - -

FREQUENCY= 3.0000E+00 MHZ
 WAVELENGTH= 9.9933E+01 METERS

- - - ANTENNA ENVIRONMENT - - -

PERFECT GROUND

- - - STRUCTURE IMPEDANCE LOADING - - -

THIS STRUCTURE IS NOT LOADED

- - - MATRIX TIMING - - -

FILL= 0.030 SEC., FACTOR= 0.000 SEC.

- - - EXCITATION - - -

PLANE WAVE THETA= 45.00 DEG, PHI= 0.00 DEG, ETA= 0.00 DEG, TYPE -LINEAR= AXIAL RATIO= 0.000

--- CURRENTS AND LOCATION ---

LENGTHS NORMALIZED BY WAVELENGTH (OR 2.*PI/CABS(K))

SEG. NO.	TAG NO.	COORD. OF SEG. CENTER			SEG. LENGTH	CURRENT (AMPS)			PHASE
		X	Y	Z		REAL	IMAG.	MAG.	
1	0	-0.5137	0.0000	0.1001	0.07338	9.6561E-03	-2.2202E-02	2.4211E-02	-66.495
2	0	-0.4403	0.0000	0.1001	0.07338	2.3188E-02	-6.0451E-02	6.4746E-02	-69.014
3	0	-0.3669	0.0000	0.1001	0.07338	2.9765E-02	-8.8239E-02	9.3124E-02	-71.360
4	0	-0.2935	0.0000	0.1001	0.07338	2.9987E-02	-1.0121E-01	1.0556E-01	-73.496
5	0	-0.2201	0.0000	0.1001	0.07338	2.5315E-02	-9.6765E-02	1.0002E-01	-75.339
6	0	-0.1468	0.0000	0.1001	0.07338	1.7997E-02	-7.5366E-02	7.7485E-02	-76.569
7	0	-0.0734	0.0000	0.1001	0.07338	1.0529E-02	-4.0582E-02	4.1926E-02	-75.455
8	0	0.0000	0.0000	0.1001	0.07338	5.0481E-03	1.5152E-03	5.2706E-03	16.708
9	0	0.0734	0.0000	0.1001	0.07338	2.8281E-03	4.3477E-02	4.3569E-02	86.278
10	0	0.1468	0.0000	0.1001	0.07338	4.0022E-03	7.7882E-02	7.7985E-02	87.058
11	0	0.2201	0.0000	0.1001	0.07338	7.5626E-03	9.8727E-02	9.9016E-02	85.620
12	0	0.2935	0.0000	0.1001	0.07338	1.1641E-02	1.0254E-01	1.0320E-01	83.523
13	0	0.3669	0.0000	0.1001	0.07338	1.3997E-02	8.8980E-02	9.0074E-02	81.060
14	0	0.4403	0.0000	0.1001	0.07338	1.2583E-02	6.0736E-02	6.2025E-02	78.296
15	0	0.5137	0.0000	0.1001	0.07338	5.8545E-03	2.2237E-02	2.2995E-02	75.250

--- RADIATION PATTERNS ---

-- ANGLES --		- CROSS SECTION -			--- POLARIZATION ---			--- E(THETA) ---		--- E(PHI) ---	
THETA DEGREES	PHI DEGREES	VERT. DB	HOR. DB	TOTAL DB	AXIAL RATIO	TILT DEG.	SENSE	MAGNITUDE VOLTS	PHASE DEGREES	MAGNITUDE VOLTS	PHASE DEGREES
90.00	0.00	-999.99	-999.99	-999.99	0.00000	0.00		3.50799E-22	-175.55	0.00000E+00	0.00
80.00	0.00	-36.78	-999.99	-36.78	0.00000	0.00	LINEAR	4.08381E-01	-175.53	0.00000E+00	0.00
70.00	0.00	-24.91	-999.99	-24.91	0.00000	0.00	LINEAR	1.60224E+00	-175.47	0.00000E+00	0.00
60.00	0.00	-18.29	-999.99	-18.29	0.00000	0.00	LINEAR	3.43165E+00	-175.38	0.00000E+00	0.00
50.00	0.00	-14.20	-999.99	-14.20	0.00000	0.00	LINEAR	5.49969E+00	-175.26	0.00000E+00	0.00
40.00	0.00	-12.00	-999.99	-12.00	0.00000	0.00	LINEAR	7.08355E+00	-175.08	0.00000E+00	0.00
30.00	0.00	-11.77	-999.99	-11.77	0.00000	0.00	LINEAR	7.27027E+00	-174.82	0.00000E+00	0.00
20.00	0.00	-14.39	-999.99	-14.39	0.00000	0.00	LINEAR	5.37929E+00	-174.28	0.00000E+00	0.00
10.00	0.00	-25.57	-999.99	-25.57	0.00000	0.00	LINEAR	1.48515E+00	-171.00	0.00000E+00	0.00
0.00	0.00	-18.38	-999.99	-18.38	0.00000	0.00	LINEAR	3.39531E+00	3.10	0.00000E+00	0.00
-10.00	0.00	-11.31	-999.99	-11.31	0.00000	0.00	LINEAR	7.66720E+00	4.34	0.00000E+00	0.00
-20.00	0.00	-8.98	-999.99	-8.98	0.00000	0.00	LINEAR	1.00251E+01	4.77	0.00000E+00	0.00
-30.00	0.00	-8.95	-999.99	-8.95	0.00000	0.00	LINEAR	1.00633E+01	5.05	0.00000E+00	0.00
-40.00	0.00	-10.60	-999.99	-10.60	0.00000	0.00	LINEAR	8.31609E+00	5.29	0.00000E+00	0.00
-50.00	0.00	-13.78	-999.99	-13.78	0.00000	0.00	LINEAR	5.77198E+00	5.49	0.00000E+00	0.00
-60.00	0.00	-18.58	-999.99	-18.58	0.00000	0.00	LINEAR	3.31795E+00	5.68	0.00000E+00	0.00
-70.00	0.00	-25.71	-999.99	-25.71	0.00000	0.00	LINEAR	1.46092E+00	5.82	0.00000E+00	0.00
-80.00	0.00	-37.90	-999.99	-37.90	0.00000	0.00	LINEAR	3.59182E-01	5.92	0.00000E+00	0.00
-90.00	0.00	-999.99	-999.99	-999.99	0.00000	0.00		3.04789E-22	5.96	0.00000E+00	0.00

***** INPUT LINE 7 GN 0 0 0 0 6.00000E+00 1.00000E-04 0.00000E+00 0.00000E+00 0.00000E+00 0.00000E+00
 ***** INPUT LINE 8 RP 0 19 1 1000 9.00000E+01 0.00000E+00 -1.00000E-01 0.00000E+00 0.00000E+00 0.00000E+00

--- FREQUENCY ---

FREQUENCY= 3.0000E+00 MHZ
 WAVELENGTH= 9.9933E+01 METERS

--- ANTENNA ENVIRONMENT ---

FINITE GROUND. REFLECTION COEFFICIENT APPROXIMATION
 RELATIVE DIELECTRIC CONST.= 6.000
 CONDUCTIVITY= 1.000E-04 MHOS/METER
 COMPLEX DIELECTRIC CONSTANT= 6.00000E+00-5.99183E-01

--- STRUCTURE IMPEDANCE LOADING ---

THIS STRUCTURE IS NOT LOADED

- - - MATRIX TIMING - - -

FILL= 0.030 SEC., FACTOR= 0.000 SEC.

- - - EXCITATION - - -

PLANE WAVE THETA= 45.00 DEG, PHI= 0.00 DEG, ETA= 0.00 DEG, TYPE -LINEAR= AXIAL RATIO= 0.000

- - - CURRENTS AND LOCATION - - -

LENGTHS NORMALIZED BY WAVELENGTH (OR 2.*PI/CABS(K))

SEG. NO.	TAG NO.	COORD. OF SEG. CENTER			SEG. LENGTH	CURRENT (AMPS)			PHASE
		X	Y	Z		REAL	IMAG.	MAG.	
1	0	-0.5137	0.0000	0.1001	0.07338	-7.7095E-03	-2.4421E-02	2.5609E-02	-107.521
2	0	-0.4403	0.0000	0.1001	0.07338	-2.2707E-02	-6.4147E-02	6.8047E-02	-109.494
3	0	-0.3669	0.0000	0.1001	0.07338	-3.5359E-02	-9.0527E-02	9.7187E-02	-111.335
4	0	-0.2935	0.0000	0.1001	0.07338	-4.2711E-02	-1.0065E-01	1.0934E-01	-112.993
5	0	-0.2201	0.0000	0.1001	0.07338	-4.2368E-02	-9.3636E-02	1.0277E-01	-114.345
6	0	-0.1468	0.0000	0.1001	0.07338	-3.3299E-02	-7.1510E-02	7.8883E-02	-114.969
7	0	-0.0734	0.0000	0.1001	0.07338	-1.6198E-02	-3.8904E-02	4.2142E-02	-112.605
8	0	0.0000	0.0000	0.1001	0.07338	6.5210E-03	-2.1111E-03	6.8543E-03	-17.939
9	0	0.0734	0.0000	0.1001	0.07338	3.1092E-02	3.2145E-02	4.4721E-02	45.953
10	0	0.1468	0.0000	0.1001	0.07338	5.3059E-02	5.7996E-02	7.8606E-02	47.546
11	0	0.2201	0.0000	0.1001	0.07338	6.8107E-02	7.1519E-02	9.8760E-02	46.400
12	0	0.2935	0.0000	0.1001	0.07338	7.2903E-02	7.1391E-02	1.0204E-01	44.400
13	0	0.3669	0.0000	0.1001	0.07338	6.5755E-02	5.8999E-02	8.8344E-02	41.900
14	0	0.4403	0.0000	0.1001	0.07338	4.6930E-02	3.7971E-02	6.0367E-02	38.976
15	0	0.5137	0.0000	0.1001	0.07338	1.8053E-02	1.2945E-02	2.2215E-02	35.642

- - - RADIATION PATTERNS - - -

- - ANGLES - -		- CROSS SECTION -			- - - POLARIZATION - - -			- - - E(THETA) - - -		- - - E(PHI) - - -	
THETA DEGREES	PHI DEGREES	VERT. DB	HOR. DB	TOTAL DB	AXIAL RATIO	TILT DEG.	SENSE	MAGNITUDE VOLTS	PHASE DEGREES	MAGNITUDE VOLTS	PHASE DEGREES
90.00	0.00	-999.99	-999.99	-999.99	0.000000	0.00	LINEAR	1.09720E-10	-125.54	0.00000E+00	0.00
80.00	0.00	-20.83	-999.99	-20.83	0.000000	0.00	LINEAR	2.56116E+00	58.15	0.00000E+00	0.00
70.00	0.00	-17.03	-999.99	-17.03	0.000000	0.00	LINEAR	3.96646E+00	66.92	0.00000E+00	0.00
60.00	0.00	-14.91	-999.99	-14.91	0.000000	0.00	LINEAR	5.06488E+00	79.04	0.00000E+00	0.00
50.00	0.00	-13.32	-999.99	-13.32	0.000000	0.00	LINEAR	6.08613E+00	91.45	0.00000E+00	0.00
40.00	0.00	-12.41	-999.99	-12.41	0.000000	0.00	LINEAR	6.75442E+00	101.83	0.00000E+00	0.00
30.00	0.00	-12.82	-999.99	-12.82	0.000000	0.00	LINEAR	6.44301E+00	109.70	0.00000E+00	0.00
20.00	0.00	-15.74	-999.99	-15.74	0.000000	0.00	LINEAR	4.60348E+00	116.07	0.00000E+00	0.00
10.00	0.00	-26.88	-999.99	-26.88	0.000000	0.00	LINEAR	1.27624E+00	130.68	0.00000E+00	0.00
0.00	0.00	-19.74	-999.99	-19.74	0.000000	0.00	LINEAR	2.90333E+00	-70.75	0.00000E+00	0.00
-10.00	0.00	-12.71	-999.99	-12.71	0.000000	0.00	LINEAR	6.52623E+00	-67.06	0.00000E+00	0.00
-20.00	0.00	-10.25	-999.99	-10.25	0.000000	0.00	LINEAR	8.66635E+00	-68.08	0.00000E+00	0.00
-30.00	0.00	-9.90	-999.99	-9.90	0.000000	0.00	LINEAR	9.02110E+00	-71.67	0.00000E+00	0.00
-40.00	0.00	-10.90	-999.99	-10.90	0.000000	0.00	LINEAR	8.03581E+00	-77.94	0.00000E+00	0.00
-50.00	0.00	-12.76	-999.99	-12.76	0.000000	0.00	LINEAR	6.48622E+00	-87.17	0.00000E+00	0.00
-60.00	0.00	-15.05	-999.99	-15.05	0.000000	0.00	LINEAR	4.98288E+00	-98.67	0.00000E+00	0.00
-70.00	0.00	-17.67	-999.99	-17.67	0.000000	0.00	LINEAR	3.68641E+00	-110.10	0.00000E+00	0.00
-80.00	0.00	-21.77	-999.99	-21.77	0.000000	0.00	LINEAR	2.29887E+00	-118.44	0.00000E+00	0.00
-90.00	0.00	-999.99	-999.99	-999.99	0.000000	0.00		9.73269E-11	58.01	0.00000E+00	0.00

***** INPUT LINE 9 NX 0 0 0 0 0.00000E+00 0.00000E+00 0.00000E+00 0.00000E+00 0.00000E+00 0.00000E+00

 *
 * NUMERICAL ELECTROMAGNETICS CODE (NEC-4.1) *
 *

 SAMPLE PROBLEM FOR NEC
 STICK MODEL OF AIRCRAFT - FREE SPACE

- - - STRUCTURE SPECIFICATION - - -

COORDINATES MUST BE INPUT IN
 METERS OR BE SCALED TO METERS
 BEFORE STRUCTURE INPUT IS ENDED

WIRE NO.	X1	Y1	Z1	X2	Y2	Z2	RADIUS	NO. OF SEG.	FIRST SEG.	LAST SEG.	TAG NO.
1	0.00000	0.00000	0.00000	6.00000	0.00000	0.00000	1.00000	1	1	1	1
2	6.00000	0.00000	0.00000	44.00000	0.00000	0.00000	1.00000	6	2	7	2
3	44.00000	0.00000	0.00000	68.00000	0.00000	0.00000	1.00000	4	8	11	3
4	44.00000	0.00000	0.00000	24.00000	29.90000	0.00000	1.00000	6	12	17	4
5	44.00000	0.00000	0.00000	24.00000	-29.90000	0.00000	1.00000	6	18	23	5
6	6.00000	0.00000	0.00000	2.00000	11.30000	0.00000	1.00000	2	24	25	6
7	6.00000	0.00000	0.00000	2.00000	-11.30000	0.00000	1.00000	2	26	27	7
8	6.00000	0.00000	0.00000	2.00000	0.00000	10.00000	1.00000	2	28	29	8

TOTAL SEGMENTS USED= 29 NO. SEG. IN A SYMMETRIC CELL= 29 SYMMETRY FLAG= 0

- MULTIPLE WIRE JUNCTIONS -

JUNCTION	SEGMENTS (- FOR END 1, + FOR END 2)
1	1 -2 -24 -26 -28
2	7 -8 -12 -18

- - - SEGMENTATION DATA - - -

COORDINATES IN METERS

I+ AND I- INDICATE THE SEGMENTS BEFORE AND AFTER I

SEG. NO.	COORDINATES OF SEG. CENTER			SEG. LENGTH	ORIENTATION ANGLES		WIRE RADIUS	CONNECTION DATA			TAG NO.
	X	Y	Z		ALPHA	BETA		I-	I	I+	
1	3.00000	0.00000	0.00000	6.00000	0.00000	0.00000	1.00000	0	1	2	1
2	9.16667	0.00000	0.00000	6.33333	0.00000	0.00000	1.00000	-24	2	3	2
3	15.50000	0.00000	0.00000	6.33333	0.00000	0.00000	1.00000	2	3	4	2
4	21.83333	0.00000	0.00000	6.33333	0.00000	0.00000	1.00000	3	4	5	2
5	28.16667	0.00000	0.00000	6.33333	0.00000	0.00000	1.00000	4	5	6	2
6	34.50000	0.00000	0.00000	6.33333	0.00000	0.00000	1.00000	5	6	7	2
7	40.83333	0.00000	0.00000	6.33333	0.00000	0.00000	1.00000	6	7	8	2
8	47.00000	0.00000	0.00000	6.00000	0.00000	0.00000	1.00000	-12	8	9	3
9	53.00000	0.00000	0.00000	6.00000	0.00000	0.00000	1.00000	8	9	10	3
10	59.00000	0.00000	0.00000	6.00000	0.00000	0.00000	1.00000	9	10	11	3
11	65.00000	0.00000	0.00000	6.00000	0.00000	0.00000	1.00000	10	11	0	3
12	42.33333	2.49167	0.00000	5.99539	0.00000	123.77842	1.00000	-18	12	13	4
13	39.00000	7.47500	0.00000	5.99539	0.00000	123.77842	1.00000	12	13	14	4
14	35.66667	12.45833	0.00000	5.99539	0.00000	123.77842	1.00000	13	14	15	4
15	32.33333	17.44167	0.00000	5.99539	0.00000	123.77842	1.00000	14	15	16	4
16	29.00000	22.42500	0.00000	5.99539	0.00000	123.77842	1.00000	15	16	17	4
17	25.66667	27.40833	0.00000	5.99539	0.00000	123.77842	1.00000	16	17	0	4
18	42.33333	-2.49167	0.00000	5.99539	0.00000	-123.77842	1.00000	7	18	19	5
19	39.00000	-7.47500	0.00000	5.99539	0.00000	-123.77842	1.00000	18	19	20	5
20	35.66667	-12.45833	0.00000	5.99539	0.00000	-123.77842	1.00000	19	20	21	5
21	32.33333	-17.44167	0.00000	5.99539	0.00000	-123.77842	1.00000	20	21	22	5
22	29.00000	-22.42500	0.00000	5.99539	0.00000	-123.77842	1.00000	21	22	23	5

23	25.66667	-27.40833	0.00000	5.99539	0.00000-123.77842	1.00000	22	23	0	5
24	5.00000	2.82500	0.00000	5.99354	0.00000 109.49306	1.00000	-26	24	25	6
25	3.00000	8.47500	0.00000	5.99354	0.00000 109.49306	1.00000	24	25	0	6
26	5.00000	-2.82500	0.00000	5.99354	0.00000-109.49306	1.00000	-28	26	27	7
27	3.00000	-8.47500	0.00000	5.99354	0.00000-109.49306	1.00000	26	27	0	7
28	5.00000	0.00000	2.50000	5.38516	68.19859 180.00000	1.00000	1	28	29	8
29	3.00000	0.00000	7.50000	5.38516	68.19859 180.00000	1.00000	28	29	0	8

```

***** INPUT LINE 1 FR 0 1 0 0 3.00000E+00 0.00000E+00 0.00000E+00 0.00000E+00 0.00000E+00 0.00000E+00
***** INPUT LINE 2 EX 1 1 1 0 0.00000E+00 0.00000E+00 0.00000E+00 0.00000E+00 0.00000E+00 0.00000E+00
***** INPUT LINE 3 RP 0 1 1 1000 0.00000E+00 0.00000E+00 0.00000E+00 0.00000E+00 0.00000E+00 0.00000E+00

```

----- FREQUENCY -----

FREQUENCY= 3.0000E+00 MHZ
WAVELENGTH= 9.9933E+01 METERS

----- ANTENNA ENVIRONMENT -----

FREE SPACE

----- STRUCTURE IMPEDANCE LOADING -----

THIS STRUCTURE IS NOT LOADED

----- MATRIX TIMING -----

FILL= 0.060 SEC., FACTOR= 0.000 SEC.

----- EXCITATION -----

PLANE WAVE THETA= 0.00 DEG, PHI= 0.00 DEG, ETA= 0.00 DEG, TYPE -LINEAR= AXIAL RATIO= 0.000

----- CURRENTS AND LOCATION -----

LENGTHS NORMALIZED BY WAVELENGTH (OR 2.*PI/CABS(K))

SEG. NO.	TAG NO.	COORD. OF SEG. CENTER			SEG. LENGTH	CURRENT (AMPS)			PHASE
		X	Y	Z		REAL	IMAG.	MAG.	
1	1	0.0300	0.0000	0.0000	0.06004	1.4842E-03	4.6709E-03	4.9011E-03	72.372
2	2	0.0917	0.0000	0.0000	0.06338	3.1084E-02	-1.5877E-02	3.4904E-02	-27.057
3	2	0.1551	0.0000	0.0000	0.06338	3.6971E-02	-3.0161E-02	4.7713E-02	-39.208
4	2	0.2185	0.0000	0.0000	0.06338	4.3427E-02	-4.8837E-02	6.5352E-02	-48.356
5	2	0.2819	0.0000	0.0000	0.06338	4.8697E-02	-6.6808E-02	8.2672E-02	-53.911
6	2	0.3452	0.0000	0.0000	0.06338	5.1695E-02	-7.9951E-02	9.5208E-02	-57.114
7	2	0.4086	0.0000	0.0000	0.06338	5.1698E-02	-8.5362E-02	9.9797E-02	-58.799
8	3	0.4703	0.0000	0.0000	0.06004	2.1042E-01	-2.0935E-01	2.9682E-01	-44.854
9	3	0.5304	0.0000	0.0000	0.06004	1.7974E-01	-1.7871E-01	2.5346E-01	-44.834
10	3	0.5904	0.0000	0.0000	0.06004	1.2893E-01	-1.2752E-01	1.8134E-01	-44.686
11	3	0.6504	0.0000	0.0000	0.06004	5.9333E-02	-5.8036E-02	8.2997E-02	-44.367
12	4	0.4236	0.0249	0.0000	0.05999	-8.3841E-02	6.5998E-02	1.0670E-01	141.791
13	4	0.3903	0.0748	0.0000	0.05999	-8.3937E-02	6.5582E-02	1.0652E-01	141.999
14	4	0.3569	0.1247	0.0000	0.05999	-7.7074E-02	5.8799E-02	9.6942E-02	142.660
15	4	0.3235	0.1745	0.0000	0.05999	-6.3325E-02	4.6369E-02	7.8487E-02	143.787
16	4	0.2902	0.2244	0.0000	0.05999	-4.4052E-02	3.0291E-02	5.3461E-02	145.487
17	4	0.2568	0.2743	0.0000	0.05999	-1.9735E-02	1.2375E-02	2.3294E-02	147.909
18	5	0.4236	-0.0249	0.0000	0.05999	-8.3841E-02	6.5998E-02	1.0670E-01	141.791
19	5	0.3903	-0.0748	0.0000	0.05999	-8.3937E-02	6.5582E-02	1.0652E-01	141.999
20	5	0.3569	-0.1247	0.0000	0.05999	-7.7074E-02	5.8799E-02	9.6942E-02	142.660
21	5	0.3235	-0.1745	0.0000	0.05999	-6.3325E-02	4.6369E-02	7.8487E-02	143.787
22	5	0.2902	-0.2244	0.0000	0.05999	-4.4052E-02	3.0291E-02	5.3461E-02	145.487
23	5	0.2568	-0.2743	0.0000	0.05999	-1.9735E-02	1.2375E-02	2.3294E-02	147.909
24	6	0.0500	0.0283	0.0000	0.05998	-9.8533E-03	4.9661E-03	1.1034E-02	153.252
25	6	0.0300	0.0848	0.0000	0.05998	-4.4639E-03	1.6451E-03	4.7573E-03	159.770

26	7	0.0500	-0.0283	0.0000	0.05998	-9.8533E-03	4.9661E-03	1.1034E-02	153.252
27	7	0.0300	-0.0848	0.0000	0.05998	-4.4639E-03	1.6451E-03	4.7573E-03	159.770
28	8	0.0500	0.0000	0.0250	0.05389	-5.3733E-03	5.1496E-03	7.4425E-03	136.218
29	8	0.0300	0.0000	0.0751	0.05389	-1.6005E-03	1.9454E-03	2.5192E-03	129.445

--- RADIATION PATTERNS ---

-- ANGLES --		- CROSS SECTION -			- - - POLARIZATION - - -			- - - E(THETA) - - -		- - - E(PHI) - - -	
THETA	PHI	VERT.	HOR.	TOTAL	AXIAL	TILT	SENSE	MAGNITUDE	PHASE	MAGNITUDE	PHASE
DEGREES	DEGREES	DB	DB	DB	RATIO	DEG.	LINEAR	VOLTS	DEGREES	VOLTS	DEGREES
0.00	0.00	-2.97	-999.99	-2.97	0.00000	0.00	LINEAR	2.00162E+01	-133.82	6.14208E-15	-99.62

***** INPUT LINE 4 EX 1 1 1 0 9.00000E+01 3.00000E+01 -9.00000E+01 0.00000E+00 0.00000E+00 0.00000E+00 0.00000E+00
 ***** INPUT LINE 5 RP 0 1 1 1000 9.00000E+01 3.00000E+01 0.00000E+00 0.00000E+00 0.00000E+00 0.00000E+00 0.00000E+00

--- EXCITATION ---

PLANE WAVE THETA= 90.00 DEG, PHI= 30.00 DEG, ETA= -90.00 DEG, TYPE -LINEAR= AXIAL RATIO= 0.000

--- CURRENTS AND LOCATION ---

LENGTHS NORMALIZED BY WAVELENGTH (OR 2.*PI/CABS(K))

SEG. NO.	TAG NO.	COORD. OF SEG. CENTER			SEG. LENGTH	- - - CURRENT (AMPS) - - -			PHASE
		X	Y	Z		REAL	IMAG.	MAG.	
1	1	0.0300	0.0000	0.0000	0.06004	2.1991E-03	3.3846E-03	4.0363E-03	56.986
2	2	0.0917	0.0000	0.0000	0.06338	6.9361E-03	1.5006E-03	7.0966E-03	12.208
3	2	0.1551	0.0000	0.0000	0.06338	7.7595E-03	-7.7728E-03	1.0983E-02	-45.049
4	2	0.2185	0.0000	0.0000	0.06338	1.0122E-02	-2.1514E-02	2.3776E-02	-64.803
5	2	0.2819	0.0000	0.0000	0.06338	1.4426E-02	-3.6488E-02	3.9236E-02	-68.428
6	2	0.3452	0.0000	0.0000	0.06338	2.0122E-02	-4.9398E-02	5.3339E-02	-67.837
7	2	0.4086	0.0000	0.0000	0.06338	2.5454E-02	-5.7453E-02	6.2839E-02	-66.105
8	3	0.4703	0.0000	0.0000	0.06004	-4.0439E-02	1.5696E-01	1.6208E-01	104.448
9	3	0.5304	0.0000	0.0000	0.06004	-2.9110E-02	1.3339E-01	1.3653E-01	102.311
10	3	0.5904	0.0000	0.0000	0.06004	-1.5427E-02	9.5148E-02	9.6390E-02	99.209
11	3	0.6504	0.0000	0.0000	0.06004	-4.0128E-03	4.3653E-02	4.3837E-02	95.252
12	4	0.4236	0.0249	0.0000	0.05999	-2.3197E-02	-2.1276E-01	2.1402E-01	-96.222
13	4	0.3903	0.0748	0.0000	0.05999	-1.5897E-02	-2.0631E-01	2.0692E-01	-94.406
14	4	0.3569	0.1247	0.0000	0.05999	-7.4584E-03	-1.8477E-01	1.8492E-01	-92.312
15	4	0.3235	0.1745	0.0000	0.05999	1.7942E-05	-1.4867E-01	1.4867E-01	-89.993
16	4	0.2902	0.2244	0.0000	0.05999	4.7939E-03	-1.0131E-01	1.0143E-01	-87.291
17	4	0.2568	0.2743	0.0000	0.05999	4.6213E-03	-4.4364E-02	4.4604E-02	-84.053
18	5	0.4236	-0.0249	0.0000	0.05999	9.5434E-02	-9.1216E-03	9.5869E-02	-5.460
19	5	0.3903	-0.0748	0.0000	0.05999	9.4091E-02	-1.0588E-02	9.4685E-02	-6.421
20	5	0.3569	-0.1247	0.0000	0.05999	8.6039E-02	-8.6666E-03	8.6475E-02	-5.752
21	5	0.3235	-0.1745	0.0000	0.05999	7.1345E-02	-4.5574E-03	7.1490E-02	-3.655
22	5	0.2902	-0.2244	0.0000	0.05999	5.0881E-02	-3.6869E-04	5.0883E-02	-0.415
23	5	0.2568	-0.2743	0.0000	0.05999	2.3781E-02	1.4851E-03	2.3827E-02	3.573
24	6	0.0500	0.0283	0.0000	0.05998	1.1446E-02	-3.6207E-02	3.7973E-02	-72.457
25	6	0.0300	0.0848	0.0000	0.05998	7.1412E-03	-2.1764E-02	2.2906E-02	-71.835
26	7	0.0500	-0.0283	0.0000	0.05998	-1.0536E-02	3.6642E-02	3.8127E-02	106.042
27	7	0.0300	-0.0848	0.0000	0.05998	-4.9814E-03	2.0858E-02	2.1444E-02	103.432
28	8	0.0500	0.0000	0.0250	0.05389	-4.7038E-03	-1.1080E-03	4.8325E-03	-166.745
29	8	0.0300	0.0000	0.0751	0.05389	-2.6531E-03	-1.3391E-03	2.9719E-03	-153.218

--- RADIATION PATTERNS ---

-- ANGLES --		- CROSS SECTION -			- - - POLARIZATION - - -			- - - E(THETA) - - -		- - - E(PHI) - - -	
THETA	PHI	VERT.	HOR.	TOTAL	AXIAL	TILT	SENSE	MAGNITUDE	PHASE	MAGNITUDE	PHASE
DEGREES	DEGREES	DB	DB	DB	RATIO	DEG.		VOLTS	DEGREES	VOLTS	DEGREES
90.00	30.00	-51.98	-9.75	-9.75	0.00087	89.56	LEFT	7.09684E-02	-58.62	9.17548E+00	-52.15

***** INPUT LINE 6 EN 0 0 0 0 0.00000E+00 0.00000E+00 0.00000E+00 0.00000E+00 0.00000E+00 0.00000E+00 0.00000E+00

RUN TIME = 0.320

4.2.5 Example 9, Scattering by a Sphere

Example 9 shows the calculation of scattering by a sphere with ka of 2.9 ($ka = 2\pi a/\lambda =$ circumference $/\lambda$.) Bistatic scattering patterns are computed in the E and H planes. Then near electric and magnetic fields are computed, starting at the center of the sphere and going out along the z , y and x axes. The fields within the sphere should be the negative of the incident field to produce zero total field. This condition is approximately satisfied in the example.

If the frequency is changed so that the internal cavity of the sphere becomes resonant ($ka = 2.744$ for the TM_{101} mode) large fields will be found inside the sphere. Such internal resonances may occur in any closed structure, and will result in large errors in the computed currents and radiated fields. Since the magnetic-field integral equation used in NEC enforces the boundary condition of zero tangential magnetic field on the inside of the surface, the surface acts as a perfect magnetic conductor on the inside. Hence, the resonant fields that are seen will be the dual of those that would exist in a perfect electric-conducting sphere. Unfortunately, while the correct magnetic currents for the internal fields would not radiate externally, the electric currents in the NEC solution radiate strongly.

A number of ways have been developed for avoiding internal resonances, one being to solve combined electric and magnetic field integral equations. The only solution to the problem in NEC is to place wires inside the sphere to destroy the resonance condition at a given frequency. Three orthogonal dipoles might be placed at the center of a sphere. If the wires are perfectly conducting the resonance would be shifted to a different frequency. However, if lossy wires are used, resonances could be reduced at all frequencies.

Input for Example 9

```

CMBISTATIC SCATTERING BY A SPHERE.
CMPATCH DATA ARE INPUT FOR A SPHERE OF 1. M. RADIUS
CMTHE SPHERE IS THEN SCALED SO THAT KA=FREQUENCY IN MHZ.
CMTHE PATCH MODEL MAY BE USED FOR KA LESS THAN ABOUT 3.
CEFOR THIS RUN *** KA=2.9 ***
SP 0 0 .13795 .13795 .98079 78.75 45. .11957
SP 0 0 .51328 .21261 .83147 56.25 22.5 .17025
SP 0 0 .21261 .51328 .83147 56.25 67.5 .17025
SP 0 0 .80314 .21520 .55557 33.75 15. .16987
SP 0 0 .58794 .58794 .55557 33.75 45. .16987
SP 0 0 .21520 .80314 .55557 33.75 75. .16987
SP 0 0 .96194 .19134 .19509 11.25 11.25 .15028
SP 0 0 .81549 .54490 .19509 11.25 33.75 .15028
SP 0 0 .54490 .81549 .19509 11.25 56.25 .15028
SP 0 0 .19134 .96194 .19509 11.25 78.75 .15028
GX 0 111
GS 0 0 47.71465
GE
FR 0 1 0 0 2.9
EX 1 1 1 0 90. 0. 0.
RP 0 19 1 1000 90. 0. -10. 0.
RP 0 1 19 1000 90. 0. 0. 10.
NE 0 1 1 11 0. 0. 0. 0. 0. 5.
NE 0 1 11 1 0. 0. 0. 0. 5. 0.
NE 0 11 1 1 0. 0. 0. 5. 0. 0.
NH 0 1 1 11 0. 0. 0. 0. 0. 5.
NH 0 1 11 1 0. 0. 0. 0. 5. 0.
NH 0 11 1 1 0. 0. 0. 5. 0. 0.
EN

```

Output for Example 9

 *
 * NUMERICAL ELECTROMAGNETICS CODE (NEC-4.1) *
 *

 BISTATIC SCATTERING BY A SPHERE.
 PATCH DATA ARE INPUT FOR A SPHERE OF 1. M. RADIUS
 THE SPHERE IS THEN SCALED SO THAT KA=FREQUENCY IN MHZ.
 THE PATCH MODEL MAY BE USED FOR KA LESS THAN ABOUT 3.
 FOR THIS RUN *** KA=2.9 ***

- - - STRUCTURE SPECIFICATION - - -

COORDINATES MUST BE INPUT IN
 METERS OR BE SCALED TO METERS
 BEFORE STRUCTURE INPUT IS ENDED

WIRE NO.	X1	Y1	Z1	X2	Y2	Z2	RADIUS	NO. OF SEG.	FIRST SEG.	LAST SEG.	TAG NO.
1P	0.13795	0.13795	0.98079	78.75000	45.00000	0.11957					
2P	0.51328	0.21261	0.83147	56.25000	22.50000	0.17025					
3P	0.21261	0.51328	0.83147	56.25000	67.50000	0.17025					
4P	0.80314	0.21520	0.55557	33.75000	15.00000	0.16987					
5P	0.58794	0.58794	0.55557	33.75000	45.00000	0.16987					
6P	0.21520	0.80314	0.55557	33.75000	75.00000	0.16987					
7P	0.96194	0.19134	0.19509	11.25000	11.25000	0.15028					
8P	0.81549	0.54490	0.19509	11.25000	33.75000	0.15028					
9P	0.54490	0.81549	0.19509	11.25000	56.25000	0.15028					
10P	0.19134	0.96194	0.19509	11.25000	78.75000	0.15028					

STRUCTURE REFLECTED ALONG THE AXES X Y Z. TAGS INCREMENTED BY 0
 STRUCTURE SCALED BY FACTOR 47.71465

TOTAL SEGMENTS USED= 0 NO. SEG. IN A SYMMETRIC CELL= 0 SYMMETRY FLAG= 2
 TOTAL PATCHES USED= 80 NO. PATCHES IN A SYMMETRIC CELL= 10
 STRUCTURE HAS 3 PLANES OF SYMMETRY

- - - SURFACE PATCH DATA - - -

COORDINATES IN METERS

PATCH NO.	COORD. OF PATCH CENTER			UNIT NORMAL VECTOR			PATCH AREA	COMPONENTS OF UNIT TANGENT VECTORS					
	X	Y	Z	X	Y	Z		X1	Y1	Z1	X2	Y2	Z2
1	6.58224	6.58224	46.79805	0.1379	0.1379	0.9808	272.22356	-0.7071	0.7071	0.0000	-0.6935	-0.6935	0.1951
2	24.49098	10.14461	39.67330	0.5133	0.2126	0.8315	387.60610	-0.3827	0.9239	0.0000	-0.7682	-0.3182	0.5556
3	10.14461	24.49098	39.67330	0.2126	0.5133	0.8315	387.60610	-0.9239	0.3827	0.0000	-0.3182	-0.7682	0.5556
4	38.32154	10.26819	26.50883	0.8031	0.2152	0.5556	386.74096	-0.2588	0.9659	0.0000	-0.5366	-0.1438	0.8315
5	28.05335	28.05335	26.50883	0.5879	0.5879	0.5556	386.74096	-0.7071	0.7071	0.0000	-0.3928	-0.3928	0.8315
6	10.26819	38.32154	26.50883	0.2152	0.8031	0.5556	386.74096	-0.9659	0.2588	0.0000	-0.1438	-0.5366	0.8315
7	45.89863	9.12972	9.30865	0.9619	0.1913	0.1951	342.14065	-0.1951	0.9808	0.0000	-0.1913	-0.0381	0.9808
8	38.91082	25.99971	9.30865	0.8155	0.5449	0.1951	342.14065	-0.5556	0.8315	0.0000	-0.1622	-0.1084	0.9808
9	25.99971	38.91082	9.30865	0.5449	0.8155	0.1951	342.14065	-0.8315	0.5556	0.0000	-0.1084	-0.1622	0.9808
10	9.12972	45.89863	9.30865	0.1913	0.9619	0.1951	342.14065	-0.9808	0.1951	0.0000	-0.0381	-0.1913	0.9808
11	6.58224	6.58224	-46.79805	0.1379	0.1379	-0.9808	272.22356	-0.7071	0.7071	0.0000	-0.6935	-0.6935	-0.1951
12	24.49098	10.14461	-39.67330	0.5133	0.2126	-0.8315	387.60610	-0.3827	0.9239	0.0000	-0.7682	-0.3182	-0.5556
13	10.14461	24.49098	-39.67330	0.2126	0.5133	-0.8315	387.60610	-0.9239	0.3827	0.0000	-0.3182	-0.7682	-0.5556
14	38.32154	10.26819	-26.50883	0.8031	0.2152	-0.5556	386.74096	-0.2588	0.9659	0.0000	-0.5366	-0.1438	-0.8315

15	28.05335	28.05335	-26.50883	0.5879	0.5879	-0.5556	386.74096	-0.7071	0.7071	0.0000	-0.3928	-0.3928	-0.8315
16	10.26819	38.32154	-26.50883	0.2152	0.8031	-0.5556	386.74096	-0.9659	0.2588	0.0000	-0.1438	-0.5366	-0.8315
17	45.89863	9.12972	-9.30865	0.9619	0.1913	-0.1951	342.14065	-0.1951	0.9808	0.0000	-0.1913	-0.0381	-0.9808
18	38.91082	25.99971	-9.30865	0.8155	0.5449	-0.1951	342.14065	-0.5556	0.8315	0.0000	-0.1622	-0.1084	-0.9808
19	25.99971	38.91082	-9.30865	0.5449	0.8155	-0.1951	342.14065	-0.8315	0.5556	0.0000	-0.1084	-0.1622	-0.9808
20	9.12972	45.89863	-9.30865	0.1913	0.9619	-0.1951	342.14065	-0.9808	0.1951	0.0000	-0.0381	-0.1913	-0.9808
21	6.58224	-6.58224	46.79805	0.1379	-0.1379	0.9808	272.22356	-0.7071	-0.7071	0.0000	-0.6935	0.6935	0.1951
22	24.49098	-10.14461	39.67330	0.5133	-0.2126	0.8315	387.60610	-0.3827	-0.9239	0.0000	-0.7682	0.3182	0.5556
23	10.14461	-24.49098	39.67330	0.2126	-0.5133	0.8315	387.60610	-0.9239	-0.3827	0.0000	-0.3182	0.7682	0.5556
24	38.32154	-10.26819	26.50883	0.8031	-0.2152	0.5556	386.74096	-0.2588	-0.9659	0.0000	-0.5366	0.1438	0.8315
25	28.05335	-28.05335	26.50883	0.5879	-0.5879	0.5556	386.74096	-0.7071	-0.7071	0.0000	-0.3928	0.3928	0.8315
26	10.26819	-38.32154	26.50883	0.2152	-0.8031	0.5556	386.74096	-0.9659	-0.2588	0.0000	-0.1438	0.5366	0.8315
27	45.89863	-9.12972	9.30865	0.9619	-0.1913	0.1951	342.14065	-0.1951	-0.9808	0.0000	-0.1913	0.0381	0.9808
28	38.91082	-25.99971	9.30865	0.8155	-0.5449	0.1951	342.14065	-0.5556	-0.8315	0.0000	-0.1622	0.1084	0.9808
29	25.99971	-38.91082	9.30865	0.5449	-0.8155	0.1951	342.14065	-0.8315	-0.5556	0.0000	-0.1084	0.1622	0.9808
30	9.12972	-45.89863	9.30865	0.1913	-0.9619	0.1951	342.14065	-0.9808	-0.1951	0.0000	-0.0381	0.1913	0.9808
31	6.58224	-6.58224	-46.79805	0.1379	-0.1379	-0.9808	272.22356	-0.7071	-0.7071	0.0000	-0.6935	0.6935	-0.1951
32	24.49098	-10.14461	-39.67330	0.5133	-0.2126	-0.8315	387.60610	-0.3827	-0.9239	0.0000	-0.7682	0.3182	-0.5556
33	10.14461	-24.49098	-39.67330	0.2126	-0.5133	-0.8315	387.60610	-0.9239	-0.3827	0.0000	-0.3182	0.7682	-0.5556
34	38.32154	-10.26819	-26.50883	0.8031	-0.2152	-0.5556	386.74096	-0.2588	-0.9659	0.0000	-0.5366	0.1438	-0.8315
35	28.05335	-28.05335	-26.50883	0.5879	-0.5879	-0.5556	386.74096	-0.7071	-0.7071	0.0000	-0.3928	0.3928	-0.8315
36	10.26819	-38.32154	-26.50883	0.2152	-0.8031	-0.5556	386.74096	-0.9659	-0.2588	0.0000	-0.1438	0.5366	-0.8315
37	45.89863	-9.12972	-9.30865	0.9619	-0.1913	-0.1951	342.14065	-0.1951	-0.9808	0.0000	-0.1913	0.0381	-0.9808
38	38.91082	-25.99971	-9.30865	0.8155	-0.5449	-0.1951	342.14065	-0.5556	-0.8315	0.0000	-0.1622	0.1084	-0.9808
39	25.99971	-38.91082	-9.30865	0.5449	-0.8155	-0.1951	342.14065	-0.8315	-0.5556	0.0000	-0.1084	0.1622	-0.9808
40	9.12972	-45.89863	-9.30865	0.1913	-0.9619	-0.1951	342.14065	-0.9808	-0.1951	0.0000	-0.0381	0.1913	-0.9808
41	-6.58224	6.58224	46.79805	-0.1379	0.1379	0.9808	272.22356	0.7071	0.7071	0.0000	0.6935	-0.6935	0.1951
42	-24.49098	10.14461	39.67330	-0.5133	0.2126	0.8315	387.60610	0.3827	0.9239	0.0000	0.7682	-0.3182	0.5556
43	-10.14461	24.49098	39.67330	-0.2126	0.5133	0.8315	387.60610	0.9239	0.3827	0.0000	0.3182	-0.7682	0.5556
44	-38.32154	10.26819	-26.50883	-0.8031	0.2152	0.5556	386.74096	0.2588	0.9659	0.0000	0.5366	-0.1438	0.8315
45	-28.05335	28.05335	26.50883	-0.5879	0.5879	0.5556	386.74096	0.7071	0.7071	0.0000	0.3928	-0.3928	0.8315
46	-10.26819	38.32154	26.50883	-0.2152	0.8031	0.5556	386.74096	0.9659	0.2588	0.0000	0.1438	-0.5366	0.8315
47	-45.89863	9.12972	9.30865	-0.9619	0.1913	0.1951	342.14065	0.1951	0.9808	0.0000	0.1913	-0.0381	0.9808
48	-38.91082	25.99971	9.30865	-0.8155	0.5449	0.1951	342.14065	0.5556	0.8315	0.0000	0.1622	-0.1084	0.9808
49	-25.99971	38.91082	9.30865	-0.5449	0.8155	0.1951	342.14065	0.8315	0.5556	0.0000	0.1084	-0.1622	0.9808
50	-9.12972	45.89863	9.30865	-0.1913	0.9619	0.1951	342.14065	0.9808	0.1951	0.0000	0.0381	-0.1913	0.9808
51	-6.58224	6.58224	-46.79805	-0.1379	0.1379	-0.9808	272.22356	0.7071	0.7071	0.0000	0.6935	-0.6935	-0.1951
52	-24.49098	10.14461	-39.67330	-0.5133	0.2126	-0.8315	387.60610	0.3827	0.9239	0.0000	0.7682	-0.3182	-0.5556
53	-10.14461	24.49098	-39.67330	-0.2126	0.5133	-0.8315	387.60610	0.9239	0.3827	0.0000	0.3182	-0.7682	-0.5556
54	-38.32154	10.26819	-26.50883	-0.8031	0.2152	-0.5556	386.74096	0.2588	0.9659	0.0000	0.5366	-0.1438	-0.8315
55	-28.05335	28.05335	-26.50883	-0.5879	0.5879	-0.5556	386.74096	0.7071	0.7071	0.0000	0.3928	-0.3928	-0.8315
56	-10.26819	38.32154	-26.50883	-0.2152	0.8031	-0.5556	386.74096	0.9659	0.2588	0.0000	0.1438	-0.5366	-0.8315
57	-45.89863	9.12972	-9.30865	-0.9619	0.1913	-0.1951	342.14065	0.1951	0.9808	0.0000	0.1913	-0.0381	-0.9808
58	-38.91082	25.99971	-9.30865	-0.8155	0.5449	-0.1951	342.14065	0.5556	0.8315	0.0000	0.1622	-0.1084	-0.9808
59	-25.99971	38.91082	-9.30865	-0.5449	0.8155	-0.1951	342.14065	0.8315	0.5556	0.0000	0.1084	-0.1622	-0.9808
60	-9.12972	45.89863	-9.30865	-0.1913	0.9619	-0.1951	342.14065	0.9808	0.1951	0.0000	0.0381	-0.1913	-0.9808
61	-6.58224	-6.58224	46.79805	-0.1379	-0.1379	0.9808	272.22356	0.7071	-0.7071	0.0000	0.6935	0.6935	0.1951
62	-24.49098	-10.14461	39.67330	-0.5133	-0.2126	0.8315	387.60610	0.3827	-0.9239	0.0000	0.7682	0.3182	0.5556
63	-10.14461	-24.49098	39.67330	-0.2126	-0.5133	0.8315	387.60610	0.9239	-0.3827	0.0000	0.3182	0.7682	0.5556
64	-38.32154	-10.26819	26.50883	-0.8031	-0.2152	0.5556	386.74096	0.2588	-0.9659	0.0000	0.5366	0.1438	0.8315
65	-28.05335	-28.05335	26.50883	-0.5879	-0.5879	0.5556	386.74096	0.7071	-0.7071	0.0000	0.3928	0.3928	0.8315
66	-10.26819	-38.32154	26.50883	-0.2152	-0.8031	0.5556	386.74096	0.9659	-0.2588	0.0000	0.1438	0.5366	0.8315
67	-45.89863	-9.12972	9.30865	-0.9619	-0.1913	0.1951	342.14065	0.1951	-0.9808	0.0000	0.1913	0.0381	0.9808
68	-38.91082	-25.99971	9.30865	-0.8155	-0.5449	0.1951	342.14065	0.5556	-0.8315	0.0000	0.1622	0.1084	0.9808
69	-25.99971	-38.91082	9.30865	-0.5449	-0.8155	0.1951	342.14065	0.8315	-0.5556	0.0000	0.1084	0.1622	0.9808
70	-9.12972	-45.89863	9.30865	-0.1913	-0.9619	0.1951	342.14065	0.9808	-0.1951	0.0000	0.0381	0.1913	0.9808
71	-6.58224	-6.58224	-46.79805	-0.1379	-0.1379	-0.9808	272.22356	0.7071	-0.7071	0.0000	0.6935	0.6935	-0.1951
72	-24.49098	-10.14461	-39.67330	-0.5133	-0.2126	-0.8315	387.60610	0.3827	-0.9239	0.0000	0.7682	0.3182	-0.5556
73	-10.14461	-24.49098	-39.67330	-0.2126	-0.5133	-0.8315	387.60610	0.9239	-0.3827	0.0000	0.3182	0.7682	-0.5556
74	-38.32154	-10.26819	-26.50883	-0.8031	-0.2152	-0.5556	386.74096	0.2588	-0.9659	0.0000	0.5366	0.1438	-0.8315
75	-28.05335	-28.05335	-26.50883	-0.5879	-0.5879	-0.5556	386.74096	0.7071	-0.7071	0.0000	0.3928	0.3928	-0.8315
76	-10.26819	-38.32154	-26.50883	-0.2152	-0.8031	-0.5556	386.74096	0.9659	-0.2588	0.0000	0.1438	0.5366	-0.8315
77	-45.89863	-9.12972	-9.30865	-0.9619	-0.1913	-0.1951	342.14065	0.1951	-0.9808	0.0000	0.1913	0.0381	-0.9808
78	-38.91082	-25.99971	-9.30865	-0.8155	-0.5449	-0.1951	342.14065	0.5556	-0.8315	0.0000	0.1622	0.1084	-0.9808
79	-25.99971	-38.91082	-9.30865	-0.5449	-0.8155	-0.1951	342.14065	0.8315	-0.5556	0.0000	0.1084	0.1622	-0.9808
80	-9.12972	-45.89863	-9.30865	-0.1913	-0.9619	-0.1951	342.14065	0.9808	-0.1951	0.0000	0.0381	0.1913	-0.9808

***** INPUT LINE 1 FR 0 1 0 0 2.90000E+00 0.00000E+00 0.00000E+00 0.00000E+00 0.00000E+00 0.00000E+00
***** INPUT LINE 2 EX 1 1 1 0 9.00000E+01 0.00000E+00 0.00000E+00 0.00000E+00 0.00000E+00 0.00000E+00
***** INPUT LINE 3 RP 0 19 1 1000 9.00000E+01 0.00000E+00 -1.00000E+01 0.00000E+00 0.00000E+00 0.00000E+00

- - - - - FREQUENCY - - - - -

FREQUENCY= 2.9000E+00 MHZ
WAVELENGTH= 1.0338E+02 METERS

- - - ANTENNA ENVIRONMENT - - -

FREE SPACE

- - - STRUCTURE IMPEDANCE LOADING - - -

THIS STRUCTURE IS NOT LOADED

- - - MATRIX TIMING - - -

FILL= 0.010 SEC., FACTOR= 0.010 SEC.

- - - EXCITATION - - -

PLANE WAVE THETA= 90.00 DEG, PHI= 0.00 DEG, ETA= 0.00 DEG, TYPE -LINEAR= AXIAL RATIO= 0.000

- - - - SURFACE PATCH CURRENTS - - - -

DISTANCES IN WAVELENGTHS (2.*PI/CABS(K))
CURRENT IN AMPS/METER

	PATCH CENTER			- - SURFACE COMPONENTS - -				- - - RECTANGULAR COMPONENTS - - -					
	X	Y	Z	TANGENT VECTOR 1 MAG.	PHASE	TANGENT VECTOR 2 MAG.	PHASE	REAL	IMAG.	REAL	IMAG.	REAL	IMAG.
1	0.064	0.064	0.453	2.8794E-03	-156.32	3.1198E-03	-157.39	3.86E-03	1.65E-03	1.33E-04	1.42E-05	-5.62E-04	-2.34E-04
2	0.237	0.098	0.384	1.4256E-03	-91.29	4.7156E-03	-94.79	3.15E-04	4.16E-03	9.57E-05	1.79E-04	-2.19E-04	-2.61E-03
3	0.098	0.237	0.384	3.2575E-03	-142.94	2.3664E-03	-147.56	3.04E-03	2.22E-03	5.39E-04	2.24E-04	-1.11E-03	-7.05E-04
4	0.371	0.099	0.256	6.0841E-04	-43.12	4.9604E-03	-45.55	-1.98E-03	2.01E-03	-7.05E-05	1.07E-04	2.89E-03	-2.94E-03
5	0.271	0.271	0.256	1.7787E-03	-79.48	3.9145E-03	-84.57	-3.75E-04	2.77E-03	8.40E-05	2.94E-04	3.08E-04	-3.24E-03
6	0.099	0.371	0.256	2.2829E-03	-142.59	2.2575E-03	-151.48	2.04E-03	1.49E-03	5.95E-04	2.19E-04	-1.65E-03	-8.96E-04
7	0.444	0.088	0.090	1.4688E-04	-14.13	5.2457E-03	-16.94	-9.88E-04	3.00E-04	-5.13E-05	2.30E-05	4.92E-03	-1.50E-03
8	0.376	0.251	0.090	4.6333E-04	-40.19	4.4776E-03	-43.42	-7.24E-04	6.65E-04	-5.82E-05	8.50E-05	3.19E-03	-3.02E-03
9	0.251	0.376	0.090	7.4095E-04	-85.74	3.3811E-03	-94.45	-1.74E-05	9.80E-04	7.32E-05	1.36E-04	-2.57E-04	-3.31E-03
10	0.088	0.444	0.090	8.0344E-04	-147.10	2.2400E-03	-157.22	7.40E-04	4.61E-04	2.64E-04	8.08E-05	-2.03E-03	-8.51E-04
11	0.064	0.064	-0.453	2.8794E-03	23.68	3.1198E-03	22.61	-3.86E-03	-1.65E-03	-1.33E-04	-1.42E-05	-5.62E-04	-2.34E-04
12	0.237	0.098	-0.384	1.4256E-03	88.71	4.7156E-03	85.21	-3.15E-04	-4.16E-03	-9.57E-05	-1.79E-04	-2.19E-04	-2.61E-03
13	0.098	0.237	-0.384	3.2575E-03	37.06	2.3664E-03	32.44	-3.04E-03	-2.22E-03	-5.39E-04	-2.24E-04	-1.11E-03	-7.05E-04
14	0.371	0.099	-0.256	6.0841E-04	136.88	4.9604E-03	134.45	1.98E-03	-2.01E-03	7.05E-05	-1.07E-04	2.89E-03	-2.94E-03
15	0.271	0.271	-0.256	1.7787E-03	100.52	3.9145E-03	95.43	3.75E-04	-2.77E-03	-8.40E-05	-2.94E-04	3.08E-04	-3.24E-03
16	0.099	0.371	-0.256	2.2829E-03	37.41	2.2575E-03	28.52	-2.04E-03	-1.49E-03	-5.95E-04	-2.19E-04	-1.65E-03	-8.96E-04
17	0.444	0.088	-0.090	1.4688E-04	165.87	5.2457E-03	163.06	9.88E-04	-3.00E-04	5.13E-05	-2.30E-05	4.92E-03	-1.50E-03
18	0.376	0.251	-0.090	4.6333E-04	139.81	4.4776E-03	136.58	7.24E-04	-6.65E-04	5.82E-05	-8.50E-05	3.19E-03	-3.02E-03
19	0.251	0.376	-0.090	7.4095E-04	94.26	3.3811E-03	85.55	1.74E-05	-9.80E-04	-7.32E-05	-1.36E-04	-2.57E-04	-3.31E-03
20	0.088	0.444	-0.090	8.0344E-04	32.90	2.2400E-03	22.78	-7.40E-04	-4.61E-04	-2.64E-04	-8.08E-05	-2.03E-03	-8.51E-04
21	0.064	-0.064	0.453	2.8794E-03	-156.32	3.1198E-03	-157.39	3.86E-03	1.65E-03	-1.33E-04	-1.42E-05	-5.62E-04	-2.34E-04
22	0.237	-0.098	0.384	1.4256E-03	-91.29	4.7156E-03	-94.79	3.15E-04	4.16E-03	-9.57E-05	-1.79E-04	-2.19E-04	-2.61E-03
23	0.098	-0.237	0.384	3.2575E-03	-142.94	2.3664E-03	-147.56	3.04E-03	2.22E-03	-5.39E-04	-2.24E-04	-1.11E-03	-7.05E-04

24	0.371	-0.099	0.256	6.0841E-04	-43.12	4.9604E-03	-45.55	-1.98E-03	2.01E-03	7.05E-05	-1.07E-04	2.89E-03	-2.94E-03
25	0.271	-0.271	0.256	1.7787E-03	-79.48	3.9145E-03	-84.57	-3.75E-04	2.77E-03	-8.40E-05	-2.94E-04	3.08E-04	-3.24E-03
26	0.099	-0.371	0.256	2.2829E-03	-142.59	2.2575E-03	-151.48	2.04E-03	1.49E-03	-5.95E-04	-2.19E-04	-1.65E-03	-8.96E-04
27	0.444	-0.088	0.090	1.4688E-04	-14.13	5.2457E-03	-16.94	-9.88E-04	3.00E-04	5.13E-05	-2.30E-05	4.92E-03	-1.50E-03
28	0.376	-0.251	0.090	4.6333E-04	-40.19	4.4776E-03	-43.42	-7.24E-04	6.65E-04	5.82E-05	-8.50E-05	3.19E-03	-3.02E-03
29	0.251	-0.376	0.090	7.4095E-04	-85.74	3.3811E-03	-94.45	-1.74E-05	9.80E-04	-7.32E-05	-1.36E-04	-2.57E-04	-3.31E-03
30	0.088	-0.444	0.090	8.0344E-04	-147.10	2.2400E-03	-157.22	7.40E-04	4.61E-04	-2.64E-04	-8.08E-05	-2.03E-03	-8.51E-04
31	0.064	-0.064	-0.453	2.8794E-03	23.68	3.1198E-03	22.61	-3.86E-03	-1.65E-03	1.33E-04	1.42E-05	-5.62E-04	-2.34E-04
32	0.237	-0.098	-0.384	1.4256E-03	88.71	4.7156E-03	85.21	-3.15E-04	-4.16E-03	9.57E-05	1.79E-04	-2.19E-04	-2.61E-03
33	0.098	-0.237	-0.384	3.2575E-03	37.06	2.3664E-03	32.44	-3.04E-03	-2.22E-03	5.39E-04	2.24E-04	-1.11E-03	-7.05E-04
34	0.371	-0.099	-0.256	6.0841E-04	136.88	4.9604E-03	134.45	1.98E-03	-2.01E-03	-7.05E-05	1.07E-04	2.89E-03	-2.94E-03
35	0.271	-0.271	-0.256	1.7787E-03	100.52	3.9145E-03	95.43	3.75E-04	-2.77E-03	8.40E-05	2.94E-04	3.08E-04	-3.24E-03
36	0.099	-0.371	-0.256	2.2829E-03	37.41	2.2575E-03	28.52	-2.04E-03	-1.49E-03	5.95E-04	2.19E-04	-1.65E-03	-8.96E-04
37	0.444	-0.088	-0.090	1.4688E-04	165.87	5.2457E-03	163.06	9.88E-04	-3.00E-04	-5.13E-05	2.30E-05	4.92E-03	-1.50E-03
38	0.376	-0.251	-0.090	4.6333E-04	139.81	4.4776E-03	136.58	7.24E-04	-6.65E-04	-5.82E-05	8.50E-05	3.19E-03	-3.02E-03
39	0.251	-0.376	-0.090	7.4095E-04	94.26	3.3811E-03	85.55	1.74E-05	-9.80E-04	7.32E-05	1.36E-04	-2.57E-04	-3.31E-03
40	0.088	-0.444	-0.090	8.0344E-04	32.90	2.2400E-03	22.78	-7.40E-04	-4.61E-04	2.64E-04	8.08E-05	-2.03E-03	-8.51E-04
41	-0.064	0.064	0.453	2.9135E-03	-36.76	2.5234E-03	-37.39	3.04E-03	-2.30E-03	2.60E-04	-1.70E-04	3.91E-04	-2.99E-04
42	-0.237	0.098	0.384	1.9524E-03	-104.63	3.6573E-03	-105.39	-9.35E-04	-3.43E-03	-1.47E-04	-6.23E-04	-5.39E-04	-1.96E-03
43	-0.098	0.237	0.384	3.3932E-03	-51.87	6.3674E-04	-60.16	2.04E-03	-2.64E-03	5.58E-04	-5.97E-04	1.76E-04	-3.07E-04
44	-0.371	0.099	0.256	1.1507E-03	-138.16	1.8444E-03	-164.01	-1.17E-03	-4.71E-04	-5.73E-04	-6.68E-04	-1.47E-03	-4.23E-04
45	-0.271	0.271	0.256	2.6220E-03	-114.23	1.0836E-03	-121.84	-9.85E-04	-2.05E-03	-5.36E-04	-1.33E-03	-4.75E-04	-7.65E-04
46	-0.099	0.371	0.256	2.3855E-03	-52.80	4.0244E-04	137.80	1.35E-03	-1.80E-03	5.33E-04	-6.37E-04	-2.48E-04	2.25E-04
47	-0.444	0.088	0.090	3.3208E-04	-151.23	2.5093E-03	82.36	7.06E-06	4.45E-04	-2.98E-04	-2.51E-04	3.27E-04	2.44E-03
48	-0.376	0.251	0.090	8.6498E-04	-139.37	1.2097E-03	94.55	-3.80E-04	-1.17E-04	-5.35E-04	-5.99E-04	-9.42E-05	1.18E-03
49	-0.251	0.376	0.090	1.0285E-03	-108.70	3.1884E-04	82.46	-2.70E-04	-7.76E-04	-1.90E-04	-5.93E-04	4.10E-05	3.10E-04
50	-0.088	0.444	0.090	8.2755E-04	-48.33	9.1957E-04	137.33	5.14E-04	-5.83E-04	2.37E-04	-2.40E-04	-6.63E-04	6.11E-04
51	-0.064	0.064	-0.453	2.9135E-03	143.24	2.5234E-03	142.61	-3.04E-03	2.30E-03	-2.60E-04	1.70E-04	3.91E-04	-2.99E-04
52	-0.237	0.098	-0.384	1.9524E-03	75.37	3.6573E-03	74.61	9.35E-04	3.43E-03	1.47E-04	6.23E-04	-5.39E-04	-1.96E-03
53	-0.098	0.237	-0.384	3.3932E-03	128.13	6.3674E-04	119.84	-2.04E-03	2.64E-03	-5.58E-04	5.97E-04	1.76E-04	-3.07E-04
54	-0.371	0.099	-0.256	1.1507E-03	41.84	1.8444E-03	15.99	1.17E-03	4.71E-04	5.73E-04	6.68E-04	-1.47E-03	-4.23E-04
55	-0.271	0.271	-0.256	2.6220E-03	65.77	1.0836E-03	58.16	9.85E-04	2.05E-03	5.36E-04	1.33E-03	-4.75E-04	-7.65E-04
56	-0.099	0.371	-0.256	2.3855E-03	127.20	4.0244E-04	-42.20	-1.35E-03	1.80E-03	-5.33E-04	6.37E-04	-2.48E-04	2.25E-04
57	-0.444	0.088	-0.090	3.3208E-04	28.77	2.5093E-03	-97.64	-7.06E-06	-4.45E-04	2.98E-04	2.51E-04	3.27E-04	2.44E-03
58	-0.376	0.251	-0.090	8.6498E-04	40.63	1.2097E-03	-85.45	3.80E-04	1.17E-04	5.35E-04	5.99E-04	-9.42E-05	1.18E-03
59	-0.251	0.376	-0.090	1.0285E-03	71.30	3.1884E-04	-97.54	2.70E-04	7.76E-04	1.90E-04	5.93E-04	4.10E-05	3.10E-04
60	-0.088	0.444	-0.090	8.2755E-04	131.67	9.1957E-04	-42.67	-5.14E-04	5.83E-04	-2.37E-04	2.40E-04	-6.63E-04	6.11E-04
61	-0.064	-0.064	0.453	2.9135E-03	-36.76	2.5234E-03	-37.39	3.04E-03	-2.30E-03	-2.60E-04	1.70E-04	3.91E-04	-2.99E-04
62	-0.237	-0.098	0.384	1.9524E-03	-104.63	3.6573E-03	-105.39	-9.35E-04	-3.43E-03	1.47E-04	6.23E-04	-5.39E-04	-1.96E-03
63	-0.098	-0.237	0.384	3.3932E-03	-51.87	6.3674E-04	-60.16	2.04E-03	-2.64E-03	-5.58E-04	5.97E-04	1.76E-04	-3.07E-04

64	-0.371	-0.099	0.256	1.1507E-03	-138.16	1.8444E-03	-164.01	-1.17E-03	-4.71E-04	5.73E-04	6.68E-04	-1.47E-03	-4.23E-04
65	-0.271	-0.271	0.256	2.6220E-03	-114.23	1.0836E-03	-121.84	-9.85E-04	-2.05E-03	5.36E-04	1.33E-03	-4.75E-04	-7.65E-04
66	-0.099	-0.371	0.256	2.3855E-03	-52.80	4.0244E-04	137.80	1.35E-03	-1.80E-03	-5.33E-04	6.37E-04	-2.48E-04	2.25E-04
67	-0.444	-0.088	0.090	3.3208E-04	-151.23	2.5093E-03	82.36	7.06E-06	4.45E-04	2.98E-04	2.51E-04	3.27E-04	2.44E-03
68	-0.376	-0.251	0.090	8.6498E-04	-139.37	1.2097E-03	94.55	-3.80E-04	-1.17E-04	5.35E-04	5.99E-04	-9.42E-05	1.18E-03
69	-0.251	-0.376	0.090	1.0285E-03	-108.70	3.1884E-04	82.46	-2.70E-04	-7.76E-04	1.90E-04	5.93E-04	4.10E-05	3.10E-04
70	-0.088	-0.444	0.090	8.2755E-04	-48.33	9.1957E-04	137.33	5.14E-04	-5.83E-04	-2.37E-04	2.40E-04	-6.63E-04	6.11E-04
71	-0.064	-0.064	-0.453	2.9135E-03	143.24	2.5234E-03	142.61	-3.04E-03	2.30E-03	2.60E-04	-1.70E-04	3.91E-04	-2.99E-04
72	-0.237	-0.098	-0.384	1.9524E-03	75.37	3.6573E-03	74.61	9.35E-04	3.43E-03	-1.47E-04	-6.23E-04	-5.39E-04	-1.96E-03
73	-0.098	-0.237	-0.384	3.3932E-03	128.13	6.3674E-04	119.84	-2.04E-03	2.64E-03	5.58E-04	-5.97E-04	1.76E-04	-3.07E-04
74	-0.371	-0.099	-0.256	1.1507E-03	41.84	1.8444E-03	15.99	1.17E-03	4.71E-04	-5.73E-04	-6.68E-04	-1.47E-03	-4.23E-04
75	-0.271	-0.271	-0.256	2.6220E-03	65.77	1.0836E-03	58.16	9.85E-04	2.05E-03	-5.36E-04	-1.33E-03	-4.75E-04	-7.65E-04
76	-0.099	-0.371	-0.256	2.3855E-03	127.20	4.0244E-04	-42.20	-1.35E-03	1.80E-03	5.33E-04	-6.37E-04	-2.48E-04	2.25E-04
77	-0.444	-0.088	-0.090	3.3208E-04	28.77	2.5093E-03	-97.64	-7.06E-06	-4.45E-04	-2.98E-04	-2.51E-04	3.27E-04	2.44E-03
78	-0.376	-0.251	-0.090	8.6498E-04	40.63	1.2097E-03	-85.45	3.80E-04	1.17E-04	-5.35E-04	-5.99E-04	-9.42E-05	1.18E-03
79	-0.251	-0.376	-0.090	1.0285E-03	71.30	3.1884E-04	-97.54	2.70E-04	7.76E-04	-1.90E-04	-5.93E-04	4.10E-05	3.10E-04
80	-0.088	-0.444	-0.090	8.2755E-04	131.67	9.1957E-04	-42.67	-5.14E-04	5.83E-04	2.37E-04	-2.40E-04	-6.63E-04	6.11E-04

--- RADIATION PATTERNS ---

-- ANGLES --		- CROSS SECTION -			- - - POLARIZATION - - -			- - - E(THETA) - - -		- - - E(PHI) - - -	
THETA	PHI	VERT.	HOR.	TOTAL	AXIAL	TILT	SENSE	MAGNITUDE	PHASE	MAGNITUDE	PHASE
DEGREES	DEGREES	DB	DB	DB	RATIO	DEG.		VOLTS	DEGREES	VOLTS	DEGREES
90.00	0.00	-4.44	-999.99	-4.44	0.00000	0.00	LINEAR	1.74852E+01	163.80	2.52864E-17	0.00
80.00	0.00	-4.04	-999.99	-4.04	0.00000	0.00	LINEAR	1.83237E+01	161.67	5.08879E-16	-26.57
70.00	0.00	-2.96	-999.99	-2.96	0.00000	0.00	LINEAR	2.07470E+01	156.86	5.21292E-16	112.83
60.00	0.00	-1.61	-999.99	-1.61	0.00000	0.00	LINEAR	2.42168E+01	152.14	4.77103E-16	122.01
50.00	0.00	-0.50	-999.99	-0.50	0.00000	0.00	LINEAR	2.75240E+01	148.81	4.01608E-16	28.18
40.00	0.00	-0.03	-999.99	-0.03	0.00000	0.00	LINEAR	2.90492E+01	146.61	1.50236E-15	6.77
30.00	0.00	-0.59	-999.99	-0.59	0.00000	0.00	LINEAR	2.72599E+01	144.38	2.64735E-15	-17.22
20.00	0.00	-2.73	-999.99	-2.73	0.00000	0.00	LINEAR	2.13035E+01	139.32	1.29159E-15	-23.05
10.00	0.00	-7.57	-999.99	-7.57	0.00000	0.00	LINEAR	1.22053E+01	118.96	1.06683E-15	-5.44
0.00	0.00	-8.64	-999.99	-8.64	0.00000	0.00	LINEAR	1.07892E+01	44.17	3.32468E-15	-63.34
-10.00	0.00	-1.91	-999.99	-1.91	0.00000	0.00	LINEAR	2.34179E+01	14.76	1.79894E-15	-3.63
-20.00	0.00	1.94	-999.99	1.94	0.00000	0.00	LINEAR	3.64467E+01	11.84	3.06811E-15	4.25
-30.00	0.00	3.84	-999.99	3.84	0.00000	0.00	LINEAR	4.53564E+01	16.56	1.55568E-15	-45.66
-40.00	0.00	4.51	-999.99	4.51	0.00000	0.00	LINEAR	4.89894E+01	27.10	2.25560E-15	-52.74
-50.00	0.00	4.62	-999.99	4.62	0.00000	0.00	LINEAR	4.96673E+01	44.18	4.30938E-15	4.04
-60.00	0.00	5.12	-999.99	5.12	0.00000	0.00	LINEAR	5.25643E+01	65.77	2.45903E-15	-30.26
-70.00	0.00	6.29	-999.99	6.29	0.00000	0.00	LINEAR	6.01727E+01	84.51	1.67062E-15	39.47
-80.00	0.00	7.42	-999.99	7.42	0.00000	0.00	LINEAR	6.85141E+01	95.53	6.10681E-16	27.10
-90.00	0.00	7.86	-999.99	7.86	0.00000	0.00	LINEAR	7.20510E+01	99.00	6.05423E-16	-61.29

***** INPUT LINE 4 RP 0 1 19 1000 9.00000E+01 0.00000E+00 0.00000E+00 1.00000E+01 0.00000E+00 0.00000E+00

--- RADIATION PATTERNS ---

-- ANGLES --		- CROSS SECTION -			- - - POLARIZATION - - -			- - - E(THETA) - - -		- - - E(PHI) - - -	
THETA	PHI	VERT.	HOR.	TOTAL	AXIAL	TILT	SENSE	MAGNITUDE	PHASE	MAGNITUDE	PHASE
DEGREES	DEGREES	DB	DB	DB	RATIO	DEG.		VOLTS	DEGREES	VOLTS	DEGREES
90.00	0.00	-4.44	-999.99	-4.44	0.00000	0.00	LINEAR	1.74852E+01	163.80	2.52864E-17	0.00
90.00	10.00	-4.28	-999.99	-4.28	0.00000	0.00	LINEAR	1.78240E+01	161.73	1.13663E-11	144.02
90.00	20.00	-3.79	-999.99	-3.79	0.00000	0.00	LINEAR	1.88459E+01	156.08	2.59717E-11	139.10
90.00	30.00	-3.06	-999.99	-3.06	0.00000	0.00	LINEAR	2.04929E+01	148.15	4.67209E-11	133.86
90.00	40.00	-2.25	-999.99	-2.25	0.00000	0.00	LINEAR	2.25127E+01	139.17	7.42901E-11	129.32

90.00	50.00	-1.54	-999.99	-1.54	0.00000	0.00	LINEAR	2.44308E+01	129.63	1.05227E-10	124.69
90.00	60.00	-1.11	-999.99	-1.11	0.00000	0.00	LINEAR	2.56764E+01	119.17	1.32107E-10	118.09
90.00	70.00	-1.05	-999.99	-1.05	0.00000	0.00	LINEAR	2.58334E+01	106.70	1.47676E-10	106.14
90.00	80.00	-1.34	-999.99	-1.34	0.00000	0.00	LINEAR	2.49858E+01	90.48	1.57971E-10	83.40
90.00	90.00	-1.67	-999.99	-1.67	0.00000	0.00	LINEAR	2.40598E+01	68.79	2.02739E-10	51.14
90.00	100.00	-1.45	-999.99	-1.45	0.00000	0.00	LINEAR	2.46845E+01	42.25	3.22442E-10	26.43
90.00	110.00	-0.38	-999.99	-0.38	0.00000	0.00	LINEAR	2.79070E+01	15.31	5.04013E-10	13.29
90.00	120.00	1.14	-999.99	1.14	0.00000	0.00	LINEAR	3.32413E+01	-8.45	7.06630E-10	6.47
90.00	130.00	2.70	-999.99	2.70	0.00000	0.00	LINEAR	3.97937E+01	-28.99	8.78381E-10	2.72
90.00	140.00	4.20	-999.99	4.20	0.00000	0.00	LINEAR	4.72787E+01	-46.85	9.64040E-10	0.56
90.00	150.00	5.60	-999.99	5.60	0.00000	0.00	LINEAR	5.55509E+01	-61.58	9.18975E-10	-0.72
90.00	160.00	6.78	-999.99	6.78	0.00000	0.00	LINEAR	6.36601E+01	-72.39	7.24997E-10	-1.47
90.00	170.00	7.58	-999.99	7.58	0.00000	0.00	LINEAR	6.97660E+01	-78.86	4.00601E-10	-1.86
90.00	180.00	7.86	-999.99	7.86	0.00000	0.00	LINEAR	7.20510E+01	-81.00	1.77168E-15	92.45

***** INPUT LINE 5 NE 0 1 1 11 0.00000E+00 0.00000E+00 0.00000E+00 0.00000E+00 0.00000E+00 5.00000E+00

- - - NEAR ELECTRIC FIELDS - - -

- LOCATION -			- EX -		- EY -		- EZ -	
X	Y	Z	MAGNITUDE	PHASE	MAGNITUDE	PHASE	MAGNITUDE	PHASE
METERS	METERS	METERS	VOLTS/M	DEGREES	VOLTS/M	DEGREES	VOLTS/M	DEGREES
0.0000	0.0000	0.0000	5.3914E-12	-0.82	1.0194E-17	-150.71	9.9619E-01	0.03
0.0000	0.0000	5.0000	2.4040E-02	79.71	2.1891E-17	123.69	9.9612E-01	0.04
0.0000	0.0000	10.0000	4.6950E-02	79.76	1.2058E-17	142.31	9.9585E-01	0.04
0.0000	0.0000	15.0000	6.7922E-02	79.85	3.7443E-17	-82.01	9.9523E-01	0.06
0.0000	0.0000	20.0000	8.7167E-02	80.01	7.0406E-18	-9.75	9.9357E-01	0.10
0.0000	0.0000	25.0000	1.0747E-01	80.30	3.5821E-17	49.17	9.8943E-01	0.20
0.0000	0.0000	30.0000	1.3472E-01	80.92	8.8778E-17	-23.31	9.8671E-01	0.29
0.0000	0.0000	35.0000	1.5167E-01	81.47	1.0273E-16	-45.51	1.0307E+00	-0.45
0.0000	0.0000	40.0000	1.0076E-01	-87.91	1.8336E-16	163.79	1.2282E+00	-3.24
0.0000	0.0000	45.0000	1.2887E+00	-93.79	1.3175E-15	78.90	9.2209E-01	1.86
0.0000	0.0000	50.0000	1.2772E+00	-95.81	5.1780E-16	-167.03	7.4353E-01	137.47

***** INPUT LINE 6 NE 0 1 11 1 0.00000E+00 0.00000E+00 0.00000E+00 0.00000E+00 5.00000E+00 0.00000E+00

- - - NEAR ELECTRIC FIELDS - - -

- LOCATION -			- EX -		- EY -		- EZ -	
X	Y	Z	MAGNITUDE	PHASE	MAGNITUDE	PHASE	MAGNITUDE	PHASE
METERS	METERS	METERS	VOLTS/M	DEGREES	VOLTS/M	DEGREES	VOLTS/M	DEGREES
0.0000	0.0000	0.0000	5.3914E-12	-0.82	1.0194E-17	-150.71	9.9619E-01	0.03
0.0000	5.0000	0.0000	5.3930E-12	-0.82	5.3909E-16	-116.85	9.9611E-01	0.03
0.0000	10.0000	0.0000	5.3972E-12	-0.82	1.8167E-15	-110.37	9.9588E-01	0.02
0.0000	15.0000	0.0000	5.4030E-12	-0.82	4.6219E-15	-106.76	9.9556E-01	0.00
0.0000	20.0000	0.0000	5.4084E-12	-0.81	9.8644E-15	-106.39	9.9530E-01	-0.02
0.0000	25.0000	0.0000	5.4089E-12	-0.73	1.9443E-14	-106.70	9.9550E-01	-0.05
0.0000	30.0000	0.0000	5.3947E-12	-0.21	3.7754E-14	-104.41	9.9795E-01	0.05
0.0000	35.0000	0.0000	5.3556E-12	2.48	7.1189E-14	-98.64	1.0106E+00	1.19
0.0000	40.0000	0.0000	5.3739E-12	11.81	1.0293E-13	-92.51	1.0547E+00	6.03
0.0000	45.0000	0.0000	5.5354E-12	24.39	4.4223E-14	-81.10	1.1040E+00	12.69
0.0000	50.0000	0.0000	4.8364E-12	20.73	8.1596E-14	78.12	9.8244E-01	9.30

***** INPUT LINE 7 NE 0 11 1 1 0.00000E+00 0.00000E+00 0.00000E+00 5.00000E+00 0.00000E+00 0.00000E+00

- - - NEAR ELECTRIC FIELDS - - -

- LOCATION -			- EX -		- EY -		- EZ -	
X	Y	Z	MAGNITUDE	PHASE	MAGNITUDE	PHASE	MAGNITUDE	PHASE
METERS	METERS	METERS	VOLTS/M	DEGREES	VOLTS/M	DEGREES	VOLTS/M	DEGREES
0.0000	0.0000	0.0000	5.3914E-12	-0.82	1.0194E-17	-150.71	9.9619E-01	0.03
5.0000	0.0000	0.0000	5.3430E-12	15.67	7.4771E-18	-73.14	9.8692E-01	16.52
10.0000	0.0000	0.0000	5.2617E-12	32.47	9.7385E-18	11.56	9.6987E-01	33.41
15.0000	0.0000	0.0000	5.1680E-12	49.71	9.9959E-18	176.27	9.4938E-01	50.89
20.0000	0.0000	0.0000	5.0833E-12	67.37	1.0458E-17	-162.50	9.3104E-01	69.02

25.0000	0.0000	0.0000	5.0224E-12	85.39	4.4027E-18	-142.00	9.1939E-01	87.66
30.0000	0.0000	0.0000	5.0276E-12	104.06	1.5989E-17	-110.65	9.0782E-01	106.78
35.0000	0.0000	0.0000	5.2442E-12	123.27	3.5766E-17	137.70	8.5662E-01	130.00
40.0000	0.0000	0.0000	5.2173E-12	139.61	4.1186E-17	113.26	8.5966E-01	174.27
45.0000	0.0000	0.0000	2.2342E-12	160.79	6.2075E-17	117.68	1.3188E+00	-148.03
50.0000	0.0000	0.0000	3.0973E-12	-58.73	7.5862E-17	35.87	1.2074E+00	-148.66

***** INPUT LINE 8 NH 0 1 1 11 0.00000E+00 0.00000E+00 0.00000E+00 0.00000E+00 0.00000E+00 5.00000E+00

- - - NEAR MAGNETIC FIELDS - - -

- LOCATION -			- HX -		- HY -		- HZ -	
X	Y	Z	MAGNITUDE	PHASE	MAGNITUDE	PHASE	MAGNITUDE	PHASE
METERS	METERS	METERS	AMPS/M	DEGREES	AMPS/M	DEGREES	AMPS/M	DEGREES
0.0000	0.0000	0.0000	4.7406E-19	83.43	2.2789E-03	1.96	4.1041E-20	-161.53
0.0000	0.0000	5.0000	4.1795E-19	78.78	2.2876E-03	1.91	9.6028E-20	3.84
0.0000	0.0000	10.0000	2.9369E-19	78.69	2.3137E-03	1.77	1.0665E-20	54.86
0.0000	0.0000	15.0000	3.6066E-19	136.33	2.3568E-03	1.55	2.3009E-19	-26.81
0.0000	0.0000	20.0000	2.2779E-19	149.62	2.4177E-03	1.26	2.3593E-20	18.40
0.0000	0.0000	25.0000	2.2024E-19	151.27	2.5014E-03	0.91	3.5637E-19	37.54
0.0000	0.0000	30.0000	7.7316E-19	177.61	2.6239E-03	0.48	4.3786E-19	-157.03
0.0000	0.0000	35.0000	1.5004E-19	83.52	2.8061E-03	-0.04	2.6426E-19	-172.17
0.0000	0.0000	40.0000	1.0779E-19	-86.40	2.9018E-03	-0.28	3.5186E-19	115.09
0.0000	0.0000	45.0000	1.5109E-19	162.38	1.9299E-03	2.40	2.9739E-19	-118.52
0.0000	0.0000	50.0000	1.2615E-19	-157.91	3.5955E-04	125.57	3.4328E-19	-174.21

***** INPUT LINE 9 NH 0 1 11 1 0.00000E+00 0.00000E+00 0.00000E+00 0.00000E+00 5.00000E+00 0.00000E+00

- - - NEAR MAGNETIC FIELDS - - -

- LOCATION -			- HX -		- HY -		- HZ -	
X	Y	Z	MAGNITUDE	PHASE	MAGNITUDE	PHASE	MAGNITUDE	PHASE
METERS	METERS	METERS	AMPS/M	DEGREES	AMPS/M	DEGREES	AMPS/M	DEGREES
0.0000	0.0000	0.0000	4.7406E-19	83.43	2.2789E-03	1.96	4.1041E-20	-161.53
0.0000	5.0000	0.0000	2.4437E-06	-33.79	2.2814E-03	1.94	1.2896E-16	-102.15
0.0000	10.0000	0.0000	4.6773E-06	-31.84	2.2888E-03	1.89	2.3888E-16	-102.08
0.0000	15.0000	0.0000	6.5547E-06	-28.51	2.3015E-03	1.81	3.1482E-16	-101.87
0.0000	20.0000	0.0000	8.0915E-06	-24.05	2.3196E-03	1.71	3.4907E-16	-101.55
0.0000	25.0000	0.0000	9.8609E-06	-20.06	2.3435E-03	1.58	3.3968E-16	-101.07
0.0000	30.0000	0.0000	1.5590E-05	-18.84	2.3757E-03	1.46	2.8399E-16	-103.23
0.0000	35.0000	0.0000	4.6067E-05	-15.18	2.4241E-03	1.45	2.2423E-16	-139.04
0.0000	40.0000	0.0000	1.8253E-04	-9.27	2.4817E-03	1.51	8.1835E-16	172.91
0.0000	45.0000	0.0000	5.5127E-04	-7.05	2.4295E-03	0.45	2.7552E-15	169.22
0.0000	50.0000	0.0000	1.0005E-03	-9.09	2.1016E-03	-4.19	5.1988E-15	167.13

***** INPUT LINE 10 NH 0 11 1 1 0.00000E+00 0.00000E+00 0.00000E+00 5.00000E+00 0.00000E+00 0.00000E+00

- - - NEAR MAGNETIC FIELDS - - -

- LOCATION -			- HX -		- HY -		- HZ -	
X	Y	Z	MAGNITUDE	PHASE	MAGNITUDE	PHASE	MAGNITUDE	PHASE
METERS	METERS	METERS	AMPS/M	DEGREES	AMPS/M	DEGREES	AMPS/M	DEGREES
0.0000	0.0000	0.0000	4.7406E-19	83.43	2.2789E-03	1.96	4.1041E-20	-161.53
5.0000	0.0000	0.0000	3.0071E-19	146.49	2.3306E-03	21.82	1.3685E-20	62.84
10.0000	0.0000	0.0000	1.4234E-19	88.64	2.4170E-03	40.81	5.2459E-20	4.40
15.0000	0.0000	0.0000	1.3953E-19	29.05	2.5179E-03	58.74	1.6581E-20	110.17
20.0000	0.0000	0.0000	3.6917E-19	-162.65	2.6126E-03	75.71	5.5785E-20	5.99
25.0000	0.0000	0.0000	2.6831E-19	-166.49	2.6847E-03	91.98	3.8366E-20	-154.85
30.0000	0.0000	0.0000	2.8866E-19	-83.26	2.7211E-03	107.70	3.5009E-20	-34.65
35.0000	0.0000	0.0000	2.8869E-19	-45.24	2.6696E-03	122.20	1.3373E-20	169.05
40.0000	0.0000	0.0000	2.6428E-19	0.37	2.2557E-03	132.88	7.3610E-20	-143.66
45.0000	0.0000	0.0000	7.4958E-19	-52.07	9.8588E-04	132.94	1.8640E-20	178.70
50.0000	0.0000	0.0000	7.7525E-19	-3.01	6.7883E-04	-24.20	1.3638E-20	-64.23

***** INPUT LINE 11 EN 0 0 0 0 0.00000E+00 0.00000E+00 0.00000E+00 0.00000E+00 0.00000E+00 0.00000E+00

RUN TIME = 0.250

4.2.6 Example 10, Horizontal Wires Near Ground

In Example 10, a horizontal dipole antenna 16 m long is modeled near the surface of a ground using the Sommerfeld solution. A file of Sommerfeld-integral values was generated by running the SOMNTX program for the ground parameters $\epsilon_g = 10$, $\sigma = 0.01$ S/m and 5 MHz. The file from SOMNTX was given the name SOMEX10.NEC

In the first data set the wire is modeled in free space and then at a height of 0.01 m over the ground. The input impedance is considerably closer to resonance when the wire is over ground, but the average gain of 1.59E-2 shows that only 0.795 percent of the input power is being radiated into the upper half space, with the rest absorbed by the ground.

In the second data set, the dipole is modeled in an infinite medium with the same ground parameters, and then buried 0.01 m below the ground surface. When the wire is in a conducting medium the segment coordinates and segment lengths in the table "CURRENTS AND LOCATION" are normalized by the quantity $|\lambda_g| = \lambda_0 |\epsilon_g - j\sigma/\omega\epsilon_0|^{-1/2}$ where λ_0 is the wavelength in free space. The normalized segment lengths should satisfy the criteria for solution accuracy as discussed in section 2.1.

In computing the radiated field in the infinite medium, a factor of e^{-jkR}/R is omitted, as is always done when the distance R is not specified on the RP command. Since the actual field has an exponential decay when k is complex, the radiated field, defined as the component of field falling off as $1/R$, is zero in a lossy medium. By omitting the exponential, NEC obtains a non-zero value that indicates the relative strength of field in any direction at a finite distance, but it should not be considered radiated field. Likewise, the average gain and radiated power cannot be interpreted in their usual senses. All power is absorbed in the medium and not radiated. While the interpretation of these values is open to question, the computed values seem more useful than printing zero. When the field is computed in a lossy medium with a ground interface, zero will be printed for the radiated field and gain, since then it is not possible to remove the exponential attenuation.

With the dipole buried 0.01 m below the ground surface, the average gain is slightly larger than when the wire was above ground. This difference is probably due to the change in current distribution when the wire is in the ground. The attenuation through 0.01 m of this ground is negligible.

In the final case, two dipoles are modeled, with one above the ground surface by 0.01 m and the other buried by the same distance. Both dipoles are driven by 1 volt sources, but opposing currents are set up in a transmission-line mode. The input resistance of the upper dipole is negative, indicating that it is absorbing power from the buried wire. The average gain and radiated power are smaller than for a single wire above or below ground, probably as a result of the large fields generated in the ground with this two-wire configuration.

Input for Example 10

```

CM Horizontal 16 m dipole
CM 1. Dipole in free space
CM 2. Dipole above ground - Ground: E = 10., SIG = 0.01 S/M, 5 MHz
CE Sommerfeld gound option
GW 1 11 -8. 0. 0.01 8. 0. 0.01 .001
GE -1
FR 0 1 0 0 5.
EX 0 1 6 0 1.
RP 0 10 2 1000 0. 0. 10. 90.
RP 0 10 10 1002 0. 0. 10. 10.
GN 2 0 0 0 10. 0.01 SOMEX10.NEC
RP 0 10 2 1000 0. 0. 10. 90.
RP 0 10 10 1002 0. 0. 10. 10.
NK
CM Horizontal 16 m dipole
CM 1. Dipole in an infinite lossy medium
CM 2. Dipole below the ground surface
CE Sommerfeld gound option - E = 10., SIG = 0.01 S/M, 5 MHz
GW 1 11 -8. 0. -0.01 8. 0. -0.01 .001
GE -1
FR 0 1 0 0 5.
EX 0 1 6 0 1.
UM 0 0 0 0 10. 0.01
RP 0 10 2 1000 0. 0. 10. 90.
RP 0 10 10 1002 0. 0. 10. 10.
CM NOTE: The above calculation of average gain in a lossy medium cannot
CM be interpreted in the usual sense. A factor of EXP(-jkR)/R
CM has been omitted from the field so that a non-zero value can
CM be obtained for R --> infinity with complex k. However, by the
CM usual definition, the far-field gain is zero in a lossy medium.
UM ! Set upper medium to free space, then use Sommerfeld ground.
GN 2 0 0 0 10. 0.01 SOMEX10.NEC
RP 0 10 2 1000 0. 0. 10. 90.
RP 0 10 10 1002 0. 0. 10. 10.
NK
CM TWO HORIZONTAL 16 M DIPOLE ANTENNAS ABOVE AND BELOW GROUND
CE SOMMERFELD GOUND OPTION - E = 10., SIG = 0.01 S/M, 5 MHz
GW 1 11 -8. 0. 0.01 8. 0. 0.01 .001
GW 2 11 -8. 0. -0.01 8. 0. -0.01 .001
GE -1
FR 0 1 0 0 5.
EX 0 1 6 0 1.
EX 0 2 6 0 1.
GN 2 0 0 0 10. 0.01 SOMEX10.NEC
RP 0 10 2 1000 0. 0. 10. 90.
RP 0 10 10 1002 0. 0. 10. 10.
EN

```

Output for Example 10

```

*****
*
* NUMERICAL ELECTROMAGNETICS CODE (NEC-4.1)
*
*****
    
```

```

*****
Horizontal 16 m dipole
1. Dipole in free space
2. Dipole above ground - Ground: E = 10., SIG = 0.01 S/M, 5 MHz
Sommerfeld gound option
*****
    
```

- - - STRUCTURE SPECIFICATION - - -

COORDINATES MUST BE INPUT IN
METERS OR BE SCALED TO METERS
BEFORE STRUCTURE INPUT IS ENDED

WIRE NO.	X1	Y1	Z1	X2	Y2	Z2	RADIUS	NO. OF SEG.	FIRST SEG.	LAST SEG.	TAG NO.
1	-8.00000	0.00000	0.01000	8.00000	0.00000	0.01000	0.00100	11	1	11	1

GROUND PLANE SPECIFIED.

TOTAL SEGMENTS USED= 11 NO. SEG. IN A SYMMETRIC CELL= 11 SYMMETRY FLAG= 0

- MULTIPLE WIRE JUNCTIONS -
JUNCTION SEGMENTS (- FOR END 1, + FOR END 2)
NONE

- - - - SEGMENTATION DATA - - - -

COORDINATES IN METERS

I+ AND I- INDICATE THE SEGMENTS BEFORE AND AFTER I

SEG. NO.	COORDINATES OF SEG. CENTER			SEG. LENGTH	ORIENTATION ANGLES		WIRE RADIUS	CONNECTION DATA			TAG NO.
	X	Y	Z		ALPHA	BETA		I-	I	I+	
1	-7.27273	0.00000	0.01000	1.45455	0.00000	0.00000	0.00100	0	1	2	1
2	-5.81818	0.00000	0.01000	1.45455	0.00000	0.00000	0.00100	1	2	3	1
3	-4.36364	0.00000	0.01000	1.45455	0.00000	0.00000	0.00100	2	3	4	1
4	-2.90909	0.00000	0.01000	1.45455	0.00000	0.00000	0.00100	3	4	5	1
5	-1.45455	0.00000	0.01000	1.45455	0.00000	0.00000	0.00100	4	5	6	1
6	0.00000	0.00000	0.01000	1.45455	0.00000	0.00000	0.00100	5	6	7	1
7	1.45455	0.00000	0.01000	1.45455	0.00000	0.00000	0.00100	6	7	8	1
8	2.90909	0.00000	0.01000	1.45455	0.00000	0.00000	0.00100	7	8	9	1
9	4.36364	0.00000	0.01000	1.45455	0.00000	0.00000	0.00100	8	9	10	1
10	5.81818	0.00000	0.01000	1.45455	0.00000	0.00000	0.00100	9	10	11	1
11	7.27273	0.00000	0.01000	1.45455	0.00000	0.00000	0.00100	10	11	0	1

```

***** INPUT LINE 1 FR 0 1 0 0 5.00000E+00 0.00000E+00 0.00000E+00 0.00000E+00 0.00000E+00 0.00000E+00
***** INPUT LINE 2 EX 0 1 6 0 1.00000E+00 0.00000E+00 0.00000E+00 0.00000E+00 0.00000E+00 0.00000E+00
***** INPUT LINE 3 RP 0 10 2 1000 0.00000E+00 0.00000E+00 1.00000E+01 9.00000E+01 0.00000E+00 0.00000E+00
    
```

----- FREQUENCY -----

FREQUENCY= 5.0000E+00 MHZ
 WAVELENGTH= 5.9960E+01 METERS

----- ANTENNA ENVIRONMENT -----

FREE SPACE

----- STRUCTURE IMPEDANCE LOADING -----

THIS STRUCTURE IS NOT LOADED

----- MATRIX TIMING -----

FILL= 0.010 SEC., FACTOR= 0.000 SEC.

----- ANTENNA INPUT PARAMETERS -----

TAG NO.	SEG. NO.	VOLTAGE (VOLTS)		CURRENT (AMPS)		IMPEDANCE (OHMS)		ADMITTANCE (MHOS)		POWER (WATTS)
		REAL	IMAG.	REAL	IMAG.	REAL	IMAG.	REAL	IMAG.	
1	6	1.0000E+00	0.0000E+00	2.12383E-05	1.13068E-03	1.66070E+01	-8.84115E+02	2.12383E-05	1.13068E-03	1.06192E-05

----- CURRENTS AND LOCATION -----

LENGTHS NORMALIZED BY WAVELENGTH (OR 2.*PI/CABS(K))

SEG. NO.	TAG NO.	COORD. OF SEG. CENTER			SEG. LENGTH	CURRENT (AMPS)			PHASE
		X	Y	Z		REAL	IMAG.	MAG.	
1	1	-0.1213	0.0000	0.0002	0.02426	3.8669E-06	1.3055E-04	1.3061E-04	88.303
2	1	-0.0970	0.0000	0.0002	0.02426	1.0130E-05	3.6692E-04	3.6706E-04	88.419
3	1	-0.0728	0.0000	0.0002	0.02426	1.4951E-05	5.8650E-04	5.8669E-04	88.540
4	1	-0.0485	0.0000	0.0002	0.02426	1.8428E-05	7.9257E-04	7.9278E-04	88.668
5	1	-0.0243	0.0000	0.0002	0.02426	2.0533E-05	9.8694E-04	9.8715E-04	88.808
6	1	0.0000	0.0000	0.0002	0.02426	2.1238E-05	1.1307E-03	1.1309E-03	88.924
7	1	0.0243	0.0000	0.0002	0.02426	2.0533E-05	9.8694E-04	9.8715E-04	88.808
8	1	0.0485	0.0000	0.0002	0.02426	1.8428E-05	7.9257E-04	7.9278E-04	88.668
9	1	0.0728	0.0000	0.0002	0.02426	1.4951E-05	5.8650E-04	5.8669E-04	88.540
10	1	0.0970	0.0000	0.0002	0.02426	1.0130E-05	3.6692E-04	3.6706E-04	88.419
11	1	0.1213	0.0000	0.0002	0.02426	3.8669E-06	1.3055E-04	1.3061E-04	88.303

----- POWER BUDGET -----

INPUT POWER = 1.0619E-05 WATTS
 RADIATED POWER= 1.0619E-05 WATTS
 WIRE LOSS = 0.0000E+00 WATTS
 EFFICIENCY = 100.00 PERCENT

----- RADIATION PATTERNS -----

-- ANGLES --		- POWER GAINS -			- POLARIZATION -			- E(THETA) -		- E(PHI) -	
THETA DEGREES	PHI DEGREES	VERT. DB	HOR. DB	TOTAL DB	AXIAL RATIO	TILT DEG.	SENSE	MAGNITUDE VOLTS	PHASE DEGREES	MAGNITUDE VOLTS	PHASE DEGREES
0.00	0.00	1.86	-999.99	1.86	0.00000	0.00	LINEAR	3.12412E-02	-1.25	0.00000E+00	0.00
10.00	0.00	1.71	-999.99	1.71	0.00000	0.00	LINEAR	3.07091E-02	-1.25	0.00000E+00	0.00
20.00	0.00	1.25	-999.99	1.25	0.00000	0.00	LINEAR	2.91449E-02	-1.25	0.00000E+00	0.00
30.00	0.00	0.47	-999.99	0.47	0.00000	0.00	LINEAR	2.66390E-02	-1.26	0.00000E+00	0.00
40.00	0.00	-0.68	-999.99	-0.68	0.00000	0.00	LINEAR	2.33254E-02	-1.26	0.00000E+00	0.00
50.00	0.00	-2.30	-999.99	-2.30	0.00000	0.00	LINEAR	1.93613E-02	-1.26	0.00000E+00	0.00
60.00	0.00	-4.57	-999.99	-4.57	0.00000	0.00	LINEAR	1.49075E-02	-1.27	0.00000E+00	0.00
70.00	0.00	-7.94	-999.99	-7.94	0.00000	0.00	LINEAR	1.01126E-02	-1.28	0.00000E+00	0.00
80.00	0.00	-13.88	-999.99	-13.88	0.00000	0.00	LINEAR	5.10641E-03	-1.29	0.00000E+00	0.00
90.00	0.00	-999.99	-999.99	-999.99	0.00000	0.00		1.49790E-13	178.70	0.00000E+00	0.00
0.00	90.00	-999.99	1.86	1.86	0.00000	90.00	LINEAR	1.59437E-13	178.75	3.12412E-02	178.75
10.00	90.00	-999.99	1.86	1.86	0.00000	90.00	LINEAR	1.57015E-13	178.75	3.12412E-02	178.75
20.00	90.00	-999.99	1.86	1.86	0.00000	90.00	LINEAR	1.49822E-13	178.75	3.12412E-02	178.75

30.00	90.00	-999.99	1.86	1.86	0.00000	90.00	LINEAR	1.38076E-13	178.74	3.12412E-02	178.74
40.00	90.00	-999.99	1.86	1.86	0.00000	90.00	LINEAR	1.22136E-13	178.74	3.12412E-02	178.74
50.00	90.00	-999.99	1.86	1.86	0.00000	90.00	LINEAR	1.02484E-13	178.73	3.12412E-02	178.73
60.00	90.00	-999.99	1.86	1.86	0.00000	90.00	LINEAR	7.97184E-14	178.72	3.12412E-02	178.72
70.00	90.00	-999.99	1.86	1.86	0.00000	90.00	LINEAR	5.45306E-14	178.71	3.12412E-02	178.71
80.00	90.00	-999.99	1.86	1.86	0.00000	90.00	LINEAR	2.76859E-14	178.70	3.12412E-02	178.70
90.00	90.00	-999.99	1.86	1.86	0.00000	-90.00	LINEAR	8.13672E-25	-1.31	3.12412E-02	178.69

***** INPUT LINE 4 RP 0 10 10 1002 0.00000E+00 0.00000E+00 1.00000E+01 1.00000E+01 0.00000E+00 0.00000E+00

--- RADIATION PATTERNS ---

- - ANGLES - -		- POWER GAINS -			- - - POLARIZATION - - -			- - - E(THETA) - - -		- - - E(PHI) - - -	
THETA	PHI	VERT.	HOR.	TOTAL	AXIAL	TILT	SENSE	MAGNITUDE	PHASE	MAGNITUDE	PHASE
DEGREES	DEGREES	DB	DB	DB	RATIO	DEG.		VOLTS	DEGREES	VOLTS	DEGREES

AVERAGE POWER GAIN= 9.97861E-01 SOLID ANGLE USED IN AVERAGING=(0.5000)*PI STERADIANS.

POWER RADIATED ASSUMING RADIATION INTO 4*PI STERADIANS = 1.05965E-05 WATTS

***** INPUT LINE 5 GN 2 0 0 0 1.00000E+01 1.00000E-02 0.00000E+00 0.00000E+00 0.00000E+00 0.00000E+00
 0.00000E+00 SOMEX10.NEC
 ***** INPUT LINE 6 RP 0 10 2 1000 0.00000E+00 0.00000E+00 1.00000E+01 9.00000E+01 0.00000E+00 0.00000E+00

--- FREQUENCY ---

FREQUENCY= 5.0000E+00 MHZ
 WAVELENGTH= 5.9960E+01 METERS

--- ANTENNA ENVIRONMENT ---

GNDINO: UNABLE TO OPEN FILE SOMEX10.NEC
 WILL COMPUTE SOMMERFELD-GROUND TABLES

Time to generate Sommerfeld ground tables = 5.89 seconds

FINITE GROUND. SOMMERFELD SOLUTION
 RELATIVE DIELECTRIC CONST.= 10.000
 CONDUCTIVITY= 1.000E-02 MHOS/METER
 COMPLEX DIELECTRIC CONSTANT= 1.00000E+01-3.59510E+01

--- STRUCTURE IMPEDANCE LOADING ---

THIS STRUCTURE IS NOT LOADED

--- MATRIX TIMING ---

FILL= 0.120 SEC., FACTOR= 0.000 SEC.

--- ANTENNA INPUT PARAMETERS ---

TAG NO.	SEG. NO.	VOLTAGE (VOLTS)		CURRENT (AMPS)		IMPEDANCE (OHMS)		ADMITTANCE (MHOS)		POWER (WATTS)
		REAL	IMAG.	REAL	IMAG.	REAL	IMAG.	REAL	IMAG.	
1	6	1.00000E+00	0.00000E+00	3.01424E-03	5.37697E-03	7.93275E+01	-1.41509E+02	3.01424E-03	5.37697E-03	1.50712E-03

- - - CURRENTS AND LOCATION - - -

LENGTHS NORMALIZED BY WAVELENGTH (OR 2.*PI/CABS(K))

SEG. NO.	TAG NO.	COORD. OF SEG. CENTER			SEG. LENGTH	CURRENT (AMPS)			PHASE
		X	Y	Z		REAL	IMAG.	MAG.	
1	1	-0.1213	0.0000	0.0002	0.02426	4.1725E-04	6.6177E-04	7.8233E-04	57.769
2	1	-0.0970	0.0000	0.0002	0.02426	1.2241E-03	1.9396E-03	2.2936E-03	57.745
3	1	-0.0728	0.0000	0.0002	0.02426	1.9386E-03	3.1140E-03	3.6682E-03	58.096
4	1	-0.0485	0.0000	0.0002	0.02426	2.5044E-03	4.1281E-03	4.8284E-03	58.756
5	1	-0.0243	0.0000	0.0002	0.02426	2.8759E-03	4.9303E-03	5.7078E-03	59.745
6	1	0.0000	0.0000	0.0002	0.02426	3.0142E-03	5.3770E-03	6.1642E-03	60.726
7	1	0.0243	0.0000	0.0002	0.02426	2.8759E-03	4.9303E-03	5.7078E-03	59.745
8	1	0.0485	0.0000	0.0002	0.02426	2.5044E-03	4.1281E-03	4.8284E-03	58.756
9	1	0.0728	0.0000	0.0002	0.02426	1.9386E-03	3.1140E-03	3.6682E-03	58.096
10	1	0.0970	0.0000	0.0002	0.02426	1.2241E-03	1.9396E-03	2.2936E-03	57.745
11	1	0.1213	0.0000	0.0002	0.02426	4.1725E-04	6.6177E-04	7.8233E-04	57.768

- - - POWER BUDGET - - -

INPUT POWER = 1.5071E-03 WATTS
 RADIATED POWER = 1.5071E-03 WATTS
 WIRE LOSS = 0.0000E+00 WATTS
 EFFICIENCY = 100.00 PERCENT

- - - RADIATION PATTERNS - - -

- - ANGLES - -		- POWER GAINS -			- - - POLARIZATION - - -			- - - E(THETA) - - -		- - - E(PHI) - - -	
THETA DEGREES	PHI DEGREES	VERT. DB	HOR. DB	TOTAL DB	AXIAL RATIO	TILT DEG.	SENSE	MAGNITUDE VOLTS	PHASE DEGREES	MAGNITUDE VOLTS	PHASE DEGREES
0.00	0.00	-14.96	-999.99	-14.96	0.00000	0.00	LINEAR	5.37219E-02	1.58	0.00000E+00	0.00
10.00	0.00	-14.99	-999.99	-14.99	0.00000	0.00	LINEAR	5.35040E-02	1.48	0.00000E+00	0.00
20.00	0.00	-15.10	-999.99	-15.10	0.00000	0.00	LINEAR	5.28540E-02	1.20	0.00000E+00	0.00
30.00	0.00	-15.28	-999.99	-15.28	0.00000	0.00	LINEAR	5.17758E-02	0.70	0.00000E+00	0.00
40.00	0.00	-15.54	-999.99	-15.54	0.00000	0.00	LINEAR	5.02481E-02	-0.07	0.00000E+00	0.00
50.00	0.00	-15.90	-999.99	-15.90	0.00000	0.00	LINEAR	4.81696E-02	-1.19	0.00000E+00	0.00
60.00	0.00	-16.45	-999.99	-16.45	0.00000	0.00	LINEAR	4.52272E-02	-2.93	0.00000E+00	0.00
70.00	0.00	-17.41	-999.99	-17.41	0.00000	0.00	LINEAR	4.05042E-02	-5.89	0.00000E+00	0.00
80.00	0.00	-19.77	-999.99	-19.77	0.00000	0.00	LINEAR	3.08560E-02	-12.02	0.00000E+00	0.00
90.00	0.00	-999.99	-999.99	-999.99	0.00000	0.00		1.77419E-12	149.13	0.00000E+00	0.00
0.00	90.00	-999.99	-14.96	-14.96	0.00000	90.00	LINEAR	2.74165E-13	-178.42	5.37219E-02	-178.42
10.00	90.00	-999.99	-15.07	-15.07	0.00000	90.00	LINEAR	2.73583E-13	-178.52	5.30106E-02	-178.34
20.00	90.00	-999.99	-15.43	-15.43	0.00000	90.00	LINEAR	2.71774E-13	-178.81	5.08806E-02	-178.08
30.00	90.00	-999.99	-16.05	-16.05	0.00000	90.00	LINEAR	2.68523E-13	-179.32	4.73440E-02	-177.66
40.00	90.00	-999.99	-17.01	-17.01	0.00000	90.00	LINEAR	2.63363E-13	179.91	4.24268E-02	-177.09
50.00	90.00	-999.99	-18.39	-18.39	0.00000	90.00	LINEAR	2.55326E-13	178.77	3.61753E-02	-176.39
60.00	90.00	-999.99	-20.41	-20.41	0.00000	90.00	LINEAR	2.42285E-13	177.02	2.86660E-02	-175.57
70.00	90.00	-999.99	-23.53	-23.53	0.00000	90.00	LINEAR	2.18872E-13	174.06	2.00146E-02	-174.65
80.00	90.00	-999.99	-29.23	-29.23	0.00000	90.00	LINEAR	1.67684E-13	167.92	1.03858E-02	-173.68
90.00	90.00	-999.99	-999.99	-999.99	0.00000	0.00		9.66066E-24	-30.94	3.12174E-13	7.32

***** INPUT LINE 7 RP 0 10 10 1002 0.00000E+00 0.00000E+00 1.00000E+01 1.00000E+01 0.00000E+00 0.00000E+00

- - - RADIATION PATTERNS - - -

- - ANGLES - -		- POWER GAINS -			- - - POLARIZATION - - -			- - - E(THETA) - - -		- - - E(PHI) - - -	
THETA DEGREES	PHI DEGREES	VERT. DB	HOR. DB	TOTAL DB	AXIAL RATIO	TILT DEG.	SENSE	MAGNITUDE VOLTS	PHASE DEGREES	MAGNITUDE VOLTS	PHASE DEGREES

AVERAGE POWER GAIN = 1.59456E-02 SOLID ANGLE USED IN AVERAGING = (0.5000)*PI STERADIANS.

POWER RADIATED ASSUMING RADIATION INTO 4*PI STERADIANS = 2.40319E-05 WATTS

***** INPUT LINE 8 NX 0 0 0 0 0.00000E+00 0.00000E+00 0.00000E+00 0.00000E+00 0.00000E+00 0.00000E+00

 *
 * NUMERICAL ELECTROMAGNETICS CODE (NEC-4.1) *
 *

 Horizontal 16 m dipole
 1. Dipole in an infinite lossy medium
 2. Dipole below the ground surface
 Sommerfeld ground option - E = 10., SIG = 0.01 S/M, 5 MHz

- - - STRUCTURE SPECIFICATION - - -
 COORDINATES MUST BE INPUT IN
 METERS OR BE SCALED TO METERS
 BEFORE STRUCTURE INPUT IS ENDED

WIRE NO.	X1	Y1	Z1	X2	Y2	Z2	RADIUS	NO. OF SEG.	FIRST SEG.	LAST SEG.	TAG NO.
1	-8.00000	0.00000	-0.01000	8.00000	0.00000	-0.01000	0.00100	11	1	11	1

GROUND PLANE SPECIFIED.

TOTAL SEGMENTS USED= 11 NO. SEG. IN A SYMMETRIC CELL= 11 SYMMETRY FLAG= 0

- MULTIPLE WIRE JUNCTIONS -
 JUNCTION SEGMENTS (- FOR END 1, + FOR END 2)
 NONE

- - - - SEGMENTATION DATA - - - -
 COORDINATES IN METERS

I+ AND I- INDICATE THE SEGMENTS BEFORE AND AFTER I

SEG. NO.	COORDINATES OF SEG. CENTER			SEG. LENGTH	ORIENTATION ANGLES		WIRE RADIUS	CONNECTION DATA			TAG NO.
	X	Y	Z		ALPHA	BETA		I-	I	I+	
1	-7.27273	0.00000	-0.01000	1.45455	0.00000	0.00000	0.00100	0	1	2	1
2	-5.81818	0.00000	-0.01000	1.45455	0.00000	0.00000	0.00100	1	2	3	1
3	-4.36364	0.00000	-0.01000	1.45455	0.00000	0.00000	0.00100	2	3	4	1
4	-2.90909	0.00000	-0.01000	1.45455	0.00000	0.00000	0.00100	3	4	5	1
5	-1.45455	0.00000	-0.01000	1.45455	0.00000	0.00000	0.00100	4	5	6	1
6	0.00000	0.00000	-0.01000	1.45455	0.00000	0.00000	0.00100	5	6	7	1
7	1.45455	0.00000	-0.01000	1.45455	0.00000	0.00000	0.00100	6	7	8	1
8	2.90909	0.00000	-0.01000	1.45455	0.00000	0.00000	0.00100	7	8	9	1
9	4.36364	0.00000	-0.01000	1.45455	0.00000	0.00000	0.00100	8	9	10	1
10	5.81818	0.00000	-0.01000	1.45455	0.00000	0.00000	0.00100	9	10	11	1
11	7.27273	0.00000	-0.01000	1.45455	0.00000	0.00000	0.00100	10	11	0	1

*****	INPUT LINE	1	FR	0	1	0	0	5.00000E+00	0.00000E+00	0.00000E+00	0.00000E+00	0.00000E+00	0.00000E+00	0.00000E+00
*****	INPUT LINE	2	EX	0	1	6	0	1.00000E+00	0.00000E+00	0.00000E+00	0.00000E+00	0.00000E+00	0.00000E+00	0.00000E+00
*****	INPUT LINE	3	UM	0	0	0	0	1.00000E+01	1.00000E-02	0.00000E+00	0.00000E+00	0.00000E+00	0.00000E+00	0.00000E+00
*****	INPUT LINE	4	RP	0	10	2	1000	0.00000E+00	0.00000E+00	1.00000E+01	9.00000E+01	0.00000E+00	0.00000E+00	0.00000E+00

- - - - - FREQUENCY - - - - -

FREQUENCY= 5.0000E+00 MHZ
 WAVELENGTH= 1.2327E+01 METERS
 SKIN DEPTH= 2.5822E+00 METERS

- - - ANTENNA ENVIRONMENT - - -

INFINITE MEDIUM
 RELATIVE DIELECTRIC CONST.= 10.000
 CONDUCTIVITY= 1.000E-02 MHOS/METER
 COMPLEX DIELECTRIC CONSTANT= 1.0000E+01-3.5951E+01

- - - STRUCTURE IMPEDANCE LOADING - - -

THIS STRUCTURE IS NOT LOADED

- - - MATRIX TIMING - - -

FILL= 0.010 SEC., FACTOR= 0.000 SEC.

- - - ANTENNA INPUT PARAMETERS - - -

TAG NO.	SEG. NO.	VOLTAGE (VOLTS)		CURRENT (AMPS)		IMPEDANCE (OHMS)		ADMITTANCE (MHOS)		POWER (WATTS)
		REAL	IMAG.	REAL	IMAG.	REAL	IMAG.	REAL	IMAG.	
1	6	1.0000E+00	0.0000E+00	4.6460E-03	-4.1091E-03	1.2076E+02	1.0681E+02	4.6460E-03	-4.1091E-03	2.3230E-03

- - - CURRENTS AND LOCATION - - -

LENGTHS NORMALIZED BY WAVELENGTH (OR 2.*PI/CABS(K))

SEG. NO.	TAG NO.	COORD. OF SEG. CENTER			SEG. LENGTH	CURRENT (AMPS)			
		X	Y	Z		REAL	IMAG.	MAG.	PHASE
1	1	-0.7409	0.0000	-0.0010	0.14819	-2.1873E-04	1.4690E-04	2.6348E-04	146.114
2	1	-0.5928	0.0000	-0.0010	0.14819	-6.9515E-04	1.9455E-04	7.2186E-04	164.365
3	1	-0.4446	0.0000	-0.0010	0.14819	-1.1394E-03	-3.9681E-04	1.2065E-03	-160.799
4	1	-0.2964	0.0000	-0.0010	0.14819	-9.4195E-04	-1.8406E-03	2.0676E-03	-117.102
5	1	-0.1482	0.0000	-0.0010	0.14819	1.1277E-03	-3.6214E-03	3.7930E-03	-72.703
6	1	0.0000	0.0000	-0.0010	0.14819	4.6461E-03	-4.1091E-03	6.2025E-03	-41.491
7	1	0.1482	0.0000	-0.0010	0.14819	1.1277E-03	-3.6214E-03	3.7930E-03	-72.703
8	1	0.2964	0.0000	-0.0010	0.14819	-9.4195E-04	-1.8406E-03	2.0676E-03	-117.102
9	1	0.4446	0.0000	-0.0010	0.14819	-1.1394E-03	-3.9681E-04	1.2065E-03	-160.799
10	1	0.5928	0.0000	-0.0010	0.14819	-6.9515E-04	1.9455E-04	7.2186E-04	164.365
11	1	0.7409	0.0000	-0.0010	0.14819	-2.1873E-04	1.4690E-04	2.6348E-04	146.114

- - - POWER BUDGET - - -

INPUT POWER = 2.3230E-03 WATTS
 RADIATED POWER= 2.3230E-03 WATTS
 WIRE LOSS = 0.0000E+00 WATTS
 EFFICIENCY = 100.00 PERCENT

- - - RADIATION PATTERNS - - -

- - ANGLES - -		- POWER GAINS -			- - - POLARIZATION - - -			- - - E(THETA) - - -		- - - E(PHI) - - -	
THETA DEGREES	PHI DEGREES	VERT. DB	HOR. DB	TOTAL DB	AXIAL RATIO	TILT DEG.	SENSE	MAGNITUDE VOLTS	PHASE DEGREES	MAGNITUDE VOLTS	PHASE DEGREES
0.00	0.00	-5.79	-999.99	-5.79	0.00000	0.00	LINEAR	6.91939E-02	-176.72	0.00000E+00	0.00
10.00	0.00	-5.53	-999.99	-5.53	0.00000	0.00	LINEAR	7.12477E-02	-175.32	0.00000E+00	0.00
20.00	0.00	-4.93	-999.99	-4.93	0.00000	0.00	LINEAR	7.63759E-02	-171.10	0.00000E+00	0.00
30.00	0.00	-4.33	-999.99	-4.33	0.00000	0.00	LINEAR	8.18868E-02	-164.27	0.00000E+00	0.00
40.00	0.00	-4.06	-999.99	-4.06	0.00000	0.00	LINEAR	8.44404E-02	-155.53	0.00000E+00	0.00
50.00	0.00	-4.40	-999.99	-4.40	0.00000	0.00	LINEAR	8.11554E-02	-145.98	0.00000E+00	0.00
60.00	0.00	-5.64	-999.99	-5.64	0.00000	0.00	LINEAR	7.03939E-02	-136.84	0.00000E+00	0.00
70.00	0.00	-8.25	-999.99	-8.25	0.00000	0.00	LINEAR	5.20974E-02	-129.30	0.00000E+00	0.00
80.00	0.00	-13.73	-999.99	-13.73	0.00000	0.00	LINEAR	2.77403E-02	-124.33	0.00000E+00	0.00

90.00	0.00	-999.99	-999.99	-999.99	0.00000	0.00		8.28686E-13	57.43	0.00000E+00	0.00
0.00	90.00	-999.99	-5.79	-5.79	0.00000	90.00	LINEAR	3.53125E-13	3.28	6.91939E-02	3.28
10.00	90.00	-999.99	-5.79	-5.79	0.00000	90.00	LINEAR	3.47781E-13	3.28	6.91980E-02	3.28
20.00	90.00	-999.99	-5.79	-5.79	0.00000	90.00	LINEAR	3.31906E-13	3.30	6.92101E-02	3.30
30.00	90.00	-999.99	-5.78	-5.78	0.00000	90.00	LINEAR	3.05974E-13	3.32	6.92298E-02	3.32
40.00	90.00	-999.99	-5.78	-5.78	0.00000	90.00	LINEAR	2.70755E-13	3.35	6.92566E-02	3.35
50.00	90.00	-999.99	-5.78	-5.78	0.00000	90.00	LINEAR	2.27299E-13	3.38	6.92897E-02	3.38
60.00	90.00	-999.99	-5.77	-5.77	0.00000	90.00	LINEAR	1.76905E-13	3.43	6.93280E-02	3.43
70.00	90.00	-999.99	-5.77	-5.77	0.00000	90.00	LINEAR	1.21084E-13	3.47	6.93704E-02	3.47
80.00	90.00	-999.99	-5.76	-5.76	0.00000	90.00	LINEAR	6.15160E-14	3.52	6.94157E-02	3.52
90.00	90.00	-999.99	-5.76	-5.76	0.00000	-90.00	LINEAR	1.80913E-24	-176.43	6.94624E-02	3.57

***** INPUT LINE 5 RP 0 10 10 1002 0.00000E+00 0.00000E+00 1.00000E+01 1.00000E+01 0.00000E+00 0.00000E+00

--- RADIATION PATTERNS ---

- - ANGLES - -		- POWER GAINS -			- - - POLARIZATION - - -			- - - E(THETA) - - -		- - - E(PHI) - - -	
THETA	PHI	VERT.	HOR.	TOTAL	AXIAL	TILT	SENSE	MAGNITUDE	PHASE	MAGNITUDE	PHASE
DEGREES	DEGREES	DB	DB	DB	RATIO	DEG.		VOLTS	DEGREES	VOLTS	DEGREES

AVERAGE POWER GAIN= 3.07473E-01 SOLID ANGLE USED IN AVERAGING=(0.5000)*PI STERADIANS.

POWER RADIATED ASSUMING RADIATION INTO 4*PI STERADIANS = 7.14269E-04 WATTS

NOTE: The above calculation of average gain in a lossy medium cannot be interpreted in the usual sense. A factor of $\text{EXP}(-jkR)/R$ has been omitted from the field so that a non-zero value can be obtained for $R \rightarrow \text{infinity}$ with complex k . However, by the usual definition, the far-field gain is zero in a lossy medium.

***** INPUT LINE 6 UM 0 0 0 0 0.00000E+00 0.00000E+00 0.00000E+00 0.00000E+00 0.00000E+00 0.00000E+00 0.00000E+00
 ***** INPUT LINE 7 GN 2 0 0 0 1.00000E+01 1.00000E-02 0.00000E+00 0.00000E+00 0.00000E+00 0.00000E+00 0.00000E+00
 ***** INPUT LINE 8 RP 0 10 2 1000 0.00000E+00 0.00000E+00 1.00000E+01 9.00000E+01 0.00000E+00 0.00000E+00

--- FREQUENCY ---

FREQUENCY= 5.0000E+00 MHZ
 WAVELENGTH= 5.9960E+01 METERS

--- ANTENNA ENVIRONMENT ---

FINITE GROUND. SOMMERFELD SOLUTION
 RELATIVE DIELECTRIC CONST.= 10.000
 CONDUCTIVITY= 1.000E-02 MHOS/METER
 COMPLEX DIELECTRIC CONSTANT= 1.00000E+01-3.59510E+01

--- STRUCTURE IMPEDANCE LOADING ---

THIS STRUCTURE IS NOT LOADED

--- MATRIX TIMING ---

FILL= 0.110 SEC., FACTOR= 0.000 SEC.

- - - ANTENNA INPUT PARAMETERS - - -

TAG NO.	SEG. NO.	VOLTAGE (VOLTS)		CURRENT (AMPS)		IMPEDANCE (OHMS)		ADMITTANCE (MHOS)		POWER (WATTS)
		REAL	IMAG.	REAL	IMAG.	REAL	IMAG.	REAL	IMAG.	
1	6	1.00000E+00	0.00000E+00	3.73947E-03	-3.02523E-03	1.61632E+02	1.30761E+02	3.73947E-03	-3.02523E-03	1.86973E-03

- - - CURRENTS AND LOCATION - - -

LENGTHS NORMALIZED BY WAVELENGTH (OR 2.*PI/CABS(K))

SEG. NO.	TAG NO.	COORD. OF SEG. CENTER			SEG. LENGTH	CURRENT (AMPS)			PHASE
		X	Y	Z		REAL	IMAG.	MAG.	
1	1	-0.7409	0.0000	-0.0010	0.14819	-2.8478E-04	-5.5907E-05	2.9022E-04	-168.893
2	1	-0.5928	0.0000	-0.0010	0.14819	-7.4081E-04	-3.1102E-04	8.0345E-04	-157.225
3	1	-0.4446	0.0000	-0.0010	0.14819	-9.0938E-04	-9.3623E-04	1.3052E-03	-134.167
4	1	-0.2964	0.0000	-0.0010	0.14819	-4.1824E-04	-1.9434E-03	1.9879E-03	-102.145
5	1	-0.1482	0.0000	-0.0010	0.14819	1.3088E-03	-2.9169E-03	3.1971E-03	-65.833
6	1	0.0000	0.0000	-0.0010	0.14819	3.7395E-03	-3.0252E-03	4.8100E-03	-38.973
7	1	0.1482	0.0000	-0.0010	0.14819	1.3089E-03	-2.9169E-03	3.1971E-03	-65.833
8	1	0.2964	0.0000	-0.0010	0.14819	-4.1823E-04	-1.9434E-03	1.9879E-03	-102.145
9	1	0.4446	0.0000	-0.0010	0.14819	-9.0936E-04	-9.3622E-04	1.3052E-03	-134.166
10	1	0.5928	0.0000	-0.0010	0.14819	-7.4079E-04	-3.1102E-04	8.0344E-04	-157.225
11	1	0.7409	0.0000	-0.0010	0.14819	-2.8477E-04	-5.5909E-05	2.9021E-04	-168.893

- - - POWER BUDGET - - -

INPUT POWER = 1.8697E-03 WATTS
 RADIATED POWER = 1.8697E-03 WATTS
 WIRE LOSS = 0.0000E+00 WATTS
 EFFICIENCY = 100.00 PERCENT

- - - RADIATION PATTERNS - - -

- - ANGLES - -		- POWER GAINS -			- - - POLARIZATION - - -			- - - E(THETA) - - -		- - - E(PHI) - - -	
THETA DEGREES	PHI DEGREES	VERT. DB	HOR. DB	TOTAL DB	AXIAL RATIO	TILT DEG.	SENSE	MAGNITUDE VOLTS	PHASE DEGREES	MAGNITUDE VOLTS	PHASE DEGREES
0.00	0.00	-24.36	-999.99	-24.36	0.00000	0.00	LINEAR	2.02759E-02	-141.75	0.00000E+00	0.00
10.00	0.00	-24.38	-999.99	-24.38	0.00000	0.00	LINEAR	2.02148E-02	-141.76	0.00000E+00	0.00
20.00	0.00	-24.46	-999.99	-24.46	0.00000	0.00	LINEAR	2.00298E-02	-141.81	0.00000E+00	0.00
30.00	0.00	-24.60	-999.99	-24.60	0.00000	0.00	LINEAR	1.97132E-02	-141.94	0.00000E+00	0.00
40.00	0.00	-24.81	-999.99	-24.81	0.00000	0.00	LINEAR	1.92430E-02	-142.25	0.00000E+00	0.00
50.00	0.00	-25.12	-999.99	-25.12	0.00000	0.00	LINEAR	1.85630E-02	-142.89	0.00000E+00	0.00
60.00	0.00	-25.62	-999.99	-25.62	0.00000	0.00	LINEAR	1.75333E-02	-144.18	0.00000E+00	0.00
70.00	0.00	-26.53	-999.99	-26.53	0.00000	0.00	LINEAR	1.57797E-02	-146.77	0.00000E+00	0.00
80.00	0.00	-28.87	-999.99	-28.87	0.00000	0.00	LINEAR	1.20599E-02	-152.66	0.00000E+00	0.00
90.00	0.00	-999.99	-999.99	-999.99	0.00000	0.00		6.99687E-13	9.15	0.00000E+00	0.00
0.00	90.00	-999.99	-24.36	-24.36	0.00000	90.00	LINEAR	1.03476E-13	38.25	2.02759E-02	38.25
10.00	90.00	-999.99	-24.47	-24.47	0.00000	90.00	LINEAR	1.03269E-13	38.16	2.00074E-02	38.34
20.00	90.00	-999.99	-24.83	-24.83	0.00000	90.00	LINEAR	1.02620E-13	37.90	1.92033E-02	38.59
30.00	90.00	-999.99	-25.45	-25.45	0.00000	90.00	LINEAR	1.01445E-13	37.43	1.78683E-02	39.01
40.00	90.00	-999.99	-26.41	-26.41	0.00000	90.00	LINEAR	9.95579E-14	36.70	1.60122E-02	39.59
50.00	90.00	-999.99	-27.79	-27.79	0.00000	90.00	LINEAR	9.65839E-14	35.62	1.36526E-02	40.29
60.00	90.00	-999.99	-29.81	-29.81	0.00000	90.00	LINEAR	9.17077E-14	33.92	1.08184E-02	41.12
70.00	90.00	-999.99	-32.93	-32.93	0.00000	90.00	LINEAR	8.28874E-14	30.99	7.55328E-03	42.03
80.00	90.00	-999.99	-38.63	-38.63	0.00000	90.00	LINEAR	6.35231E-14	24.88	3.91945E-03	43.00
90.00	90.00	-999.99	-999.99	-999.99	0.00000	0.00		3.68898E-24	-173.39	1.18738E-13	44.58

***** INPUT LINE 9 RP 0 10 10 1002 0.00000E+00 0.00000E+00 1.00000E+01 1.00000E+01 0.00000E+00 0.00000E-00

- - - RADIATION PATTERNS - - -

- - ANGLES - -		- POWER GAINS -			- - - POLARIZATION - - -			- - - E(THETA) - - -		- - - E(PHI) - - -	
THETA DEGREES	PHI DEGREES	VERT. DB	HOR. DB	TOTAL DB	AXIAL RATIO	TILT DEG.	SENSE	MAGNITUDE VOLTS	PHASE DEGREES	MAGNITUDE VOLTS	PHASE DEGREES

AVERAGE POWER GAIN = 1.87156E-03 SOLID ANGLE USED IN AVERAGING = (0.5000) * PI STERADIANS.

POWER RADIATED ASSUMING RADIATION INTO 4*PI STERADIANS = 3.49932E-06 WATTS

***** INPUT LINE 10 NX 0 0 0 0 0.00000E+00 0.00000E+00 0.00000E+00 0.00000E+00 0.00000E+00 0.00000E+00

 *
 * NUMERICAL ELECTROMAGNETICS CODE (NEC-4.1) *
 *

 TWO HORIZONTAL 16 M DIPOLE ANTENNAS ABOVE AND BELOW GROUND
 SOMMERFELD GOUND OPTION - E = 10., SIG = 0.01 S/M, 5 MHz

- - - STRUCTURE SPECIFICATION - - -
 COORDINATES MUST BE INPUT IN
 METERS OR BE SCALED TO METERS
 BEFORE STRUCTURE INPUT IS ENDED

WIRE NO.	X1	Y1	Z1	X2	Y2	Z2	RADIUS	NO. OF SEG.	FIRST SEG.	LAST SEG.	TAG NO.
1	-8.00000	0.00000	0.01000	8.00000	0.00000	0.01000	0.00100	11	1	11	1
2	-8.00000	0.00000	-0.01000	8.00000	0.00000	-0.01000	0.00100	11	12	22	2

GROUND PLANE SPECIFIED.

TOTAL SEGMENTS USED= 22 NO. SEG. IN A SYMMETRIC CELL= 22 SYMMETRY FLAG= 0

- MULTIPLE WIRE JUNCTIONS -
 JUNCTION SEGMENTS (- FOR END 1, + FOR END 2)
 NONE

- - - - SEGMENTATION DATA - - - -
 COORDINATES IN METERS

I+ AND I- INDICATE THE SEGMENTS BEFORE AND AFTER I

SEG. NO.	COORDINATES OF SEG. CENTER			SEG. LENGTH	ORIENTATION ANGLES		WIRE RADIUS	CONNECTION DATA			TAG NO.
	X	Y	Z		ALPHA	BETA		I-	I	I+	
1	-7.27273	0.00000	0.01000	1.45455	0.00000	0.00000	0.00100	0	1	2	1
2	-5.81818	0.00000	0.01000	1.45455	0.00000	0.00000	0.00100	1	2	3	1
3	-4.36364	0.00000	0.01000	1.45455	0.00000	0.00000	0.00100	2	3	4	1
4	-2.90909	0.00000	0.01000	1.45455	0.00000	0.00000	0.00100	3	4	5	1
5	-1.45455	0.00000	0.01000	1.45455	0.00000	0.00000	0.00100	4	5	6	1
6	0.00000	0.00000	0.01000	1.45455	0.00000	0.00000	0.00100	5	6	7	1
7	1.45455	0.00000	0.01000	1.45455	0.00000	0.00000	0.00100	6	7	8	1
8	2.90909	0.00000	0.01000	1.45455	0.00000	0.00000	0.00100	7	8	9	1
9	4.36364	0.00000	0.01000	1.45455	0.00000	0.00000	0.00100	8	9	10	1
10	5.81818	0.00000	0.01000	1.45455	0.00000	0.00000	0.00100	9	10	11	1
11	7.27273	0.00000	0.01000	1.45455	0.00000	0.00000	0.00100	10	11	0	1
12	-7.27273	0.00000	-0.01000	1.45455	0.00000	0.00000	0.00100	0	12	13	2
13	-5.81818	0.00000	-0.01000	1.45455	0.00000	0.00000	0.00100	12	13	14	2
14	-4.36364	0.00000	-0.01000	1.45455	0.00000	0.00000	0.00100	13	14	15	2
15	-2.90909	0.00000	-0.01000	1.45455	0.00000	0.00000	0.00100	14	15	16	2
16	-1.45455	0.00000	-0.01000	1.45455	0.00000	0.00000	0.00100	15	16	17	2
17	0.00000	0.00000	-0.01000	1.45455	0.00000	0.00000	0.00100	16	17	18	2
18	1.45455	0.00000	-0.01000	1.45455	0.00000	0.00000	0.00100	17	18	19	2
19	2.90909	0.00000	-0.01000	1.45455	0.00000	0.00000	0.00100	18	19	20	2
20	4.36364	0.00000	-0.01000	1.45455	0.00000	0.00000	0.00100	19	20	21	2
21	5.81818	0.00000	-0.01000	1.45455	0.00000	0.00000	0.00100	20	21	22	2
22	7.27273	0.00000	-0.01000	1.45455	0.00000	0.00000	0.00100	21	22	0	2

```

***** INPUT LINE 1 FR 0 1 0 0 5.00000E+00 0.00000E+00 0.00000E+00 0.00000E+00 0.00000E+00 0.00000E+00
***** INPUT LINE 2 EX 0 1 6 0 1.00000E+00 0.00000E+00 0.00000E+00 0.00000E+00 0.00000E+00 0.00000E+00
***** INPUT LINE 3 EX 0 2 6 0 1.00000E+00 0.00000E+00 0.00000E+00 0.00000E+00 0.00000E+00 0.00000E+00
***** INPUT LINE 4 GN 2 0 0 0 1.00000E+01 1.00000E-02 0.00000E+00 0.00000E+00 0.00000E+00 0.00000E+00
***** INPUT LINE 5 RP 0 10 2 1000 0.00000E+00 0.00000E+00 1.00000E+01 9.00000E+01 0.00000E+00 0.00000E+00

```

----- FREQUENCY -----

FREQUENCY= 5.0000E+00 MHZ
WAVELENGTH= 5.9960E+01 METERS

--- ANTENNA ENVIRONMENT ---

FINITE GROUND. SOMMERFELD SOLUTION
RELATIVE DIELECTRIC CONST.= 10.000
CONDUCTIVITY= 1.000E-02 MHOS/METER
COMPLEX DIELECTRIC CONSTANT= 1.00000E+01-3.59510E+01

--- STRUCTURE IMPEDANCE LOADING ---

THIS STRUCTURE IS NOT LOADED

--- MATRIX TIMING ---

FILL= 0.570 SEC., FACTOR= 0.010 SEC.

--- ANTENNA INPUT PARAMETERS ---

TAG NO.	SEG. NO.	VOLTAGE (VOLTS)		CURRENT (AMPS)		IMPEDANCE (OHMS)		ADMITTANCE (MHOS)		POWER (WATTS)
		REAL	IMAG.	REAL	IMAG.	REAL	IMAG.	REAL	IMAG.	
1	6	1.00000E+00	0.00000E+00	-1.71799E-04	1.40441E-03	-8.58191E+01	-7.01546E+02	-1.71799E-04	1.40441E-03	-8.58995E-05
2	17	1.00000E+00	0.00000E+00	3.75472E-03	-3.92425E-03	1.27289E+02	1.33036E+02	3.75472E-03	-3.92425E-03	1.87736E-03

--- CURRENTS AND LOCATION ---

LENGTHS NORMALIZED BY WAVELENGTH (OR 2.*PI/CABS(K))

SEG. NO.	TAG NO.	COORD. OF SEG. CENTER			SEG. LENGTH	CURRENT (AMPS)			PHASE
		X	Y	Z		REAL	IMAG.	MAG.	
1	1	-0.1213	0.0000	0.0002	0.02426	-1.4608E-05	1.6686E-04	1.6750E-04	95.003
2	1	-0.0970	0.0000	0.0002	0.02426	-4.5141E-05	4.9431E-04	4.9637E-04	95.218
3	1	-0.0728	0.0000	0.0002	0.02426	-7.9974E-05	7.9999E-04	8.0397E-04	95.709
4	1	-0.0485	0.0000	0.0002	0.02426	-1.1877E-04	1.0672E-03	1.0738E-03	96.350
5	1	-0.0243	0.0000	0.0002	0.02426	-1.5475E-04	1.2809E-03	1.2903E-03	96.888
6	1	0.0000	0.0000	0.0002	0.02426	-1.7180E-04	1.4044E-03	1.4149E-03	96.974
7	1	0.0243	0.0000	0.0002	0.02426	-1.5475E-04	1.2809E-03	1.2903E-03	96.888
8	1	0.0485	0.0000	0.0002	0.02426	-1.1877E-04	1.0672E-03	1.0738E-03	96.350
9	1	0.0728	0.0000	0.0002	0.02426	-7.9978E-05	7.9998E-04	8.0397E-04	95.709
10	1	0.0970	0.0000	0.0002	0.02426	-4.5144E-05	4.9431E-04	4.9636E-04	95.218
11	1	0.1213	0.0000	0.0002	0.02426	-1.4609E-05	1.6686E-04	1.6750E-04	95.004
12	2	-0.7409	0.0000	-0.0010	0.14819	-2.8361E-04	-1.5455E-04	3.2299E-04	-151.413
13	2	-0.5928	0.0000	-0.0010	0.14819	-7.3909E-04	-6.1464E-04	9.6127E-04	-140.253
14	2	-0.4446	0.0000	-0.0010	0.14819	-9.0699E-04	-1.4351E-03	1.6977E-03	-122.293
15	2	-0.2964	0.0000	-0.0010	0.14819	-4.1216E-04	-2.6155E-03	2.6477E-03	-98.955
16	2	-0.1482	0.0000	-0.0010	0.14819	1.3206E-03	-3.7312E-03	3.9581E-03	-70.509
17	2	0.0000	0.0000	-0.0010	0.14819	3.7547E-03	-3.9243E-03	5.4312E-03	-46.265
18	2	0.1482	0.0000	-0.0010	0.14819	1.3206E-03	-3.7312E-03	3.9581E-03	-70.509
19	2	0.2964	0.0000	-0.0010	0.14819	-4.1215E-04	-2.6155E-03	2.6477E-03	-98.955
20	2	0.4446	0.0000	-0.0010	0.14819	-9.0697E-04	-1.4351E-03	1.6977E-03	-122.293
21	2	0.5928	0.0000	-0.0010	0.14819	-7.3908E-04	-6.1464E-04	9.6126E-04	-140.252
22	2	0.7409	0.0000	-0.0010	0.14819	-2.8361E-04	-1.5455E-04	3.2298E-04	-151.412

--- POWER BUDGET ---

INPUT POWER = 1.7915E-03 WATTS
 RADIATED POWER= 1.7915E-03 WATTS
 WIRE LOSS = 0.0000E+00 WATTS
 EFFICIENCY = 100.00 PERCENT

--- RADIATION PATTERNS ---

-- ANGLES --		- POWER GAINS -			--- POLARIZATION ---			--- E(THETA) ---		--- E(PHI) ---	
THETA DEGREES	PHI DEGREES	VERT. DB	HOR. DB	TOTAL DB	AXIAL RATIO	TILT DEG.	SENSE	MAGNITUDE VOLTS	PHASE DEGREES	MAGNITUDE VOLTS	PHASE DEGREES
0.00	0.00	-26.38	-999.99	-26.38	0.00000	0.00	LINEAR	1.57161E-02	-144.89	0.00000E+00	0.00
10.00	0.00	-26.41	-999.99	-26.41	0.00000	0.00	LINEAR	1.56729E-02	-144.87	0.00000E+00	0.00
20.00	0.00	-26.48	-999.99	-26.48	0.00000	0.00	LINEAR	1.55412E-02	-144.82	0.00000E+00	0.00
30.00	0.00	-26.61	-999.99	-26.61	0.00000	0.00	LINEAR	1.53138E-02	-144.82	0.00000E+00	0.00
40.00	0.00	-26.81	-999.99	-26.81	0.00000	0.00	LINEAR	1.49708E-02	-144.96	0.00000E+00	0.00
50.00	0.00	-27.10	-999.99	-27.10	0.00000	0.00	LINEAR	1.44653E-02	-145.43	0.00000E+00	0.00
60.00	0.00	-27.59	-999.99	-27.59	0.00000	0.00	LINEAR	1.36845E-02	-146.55	0.00000E+00	0.00
70.00	0.00	-28.49	-999.99	-28.49	0.00000	0.00	LINEAR	1.23320E-02	-149.00	0.00000E+00	0.00
80.00	0.00	-30.82	-999.99	-30.82	0.00000	0.00	LINEAR	9.43315E-03	-154.81	0.00000E+00	0.00
90.00	0.00	-999.99	-999.99	-999.99	0.00000	0.00		5.50618E-13	7.44	0.00000E+00	0.00
0.00	90.00	-999.99	-26.38	-26.38	0.00000	90.00	LINEAR	8.02058E-14	35.11	1.57161E-02	35.11
10.00	90.00	-999.99	-26.50	-26.50	0.00000	90.00	LINEAR	8.00514E-14	35.03	1.55080E-02	35.20
20.00	90.00	-999.99	-26.86	-26.86	0.00000	90.00	LINEAR	7.95675E-14	34.79	1.48846E-02	35.46
30.00	90.00	-999.99	-27.48	-27.48	0.00000	90.00	LINEAR	7.86842E-14	34.35	1.38497E-02	35.88
40.00	90.00	-999.99	-28.43	-28.43	0.00000	90.00	LINEAR	7.72544E-14	33.66	1.24108E-02	36.45
50.00	90.00	-999.99	-29.82	-29.82	0.00000	90.00	LINEAR	7.49814E-14	32.62	1.05818E-02	37.16
60.00	90.00	-999.99	-31.84	-31.84	0.00000	90.00	LINEAR	7.12266E-14	30.96	8.38492E-03	37.98
70.00	90.00	-999.99	-34.96	-34.96	0.00000	90.00	LINEAR	6.43988E-14	28.06	5.85420E-03	38.89
80.00	90.00	-999.99	-40.66	-40.66	0.00000	90.00	LINEAR	4.93651E-14	21.96	3.03777E-03	39.87
90.00	90.00	-999.99	-999.99	-999.99	0.00000	0.00		2.88295E-24	-175.85	2.31701E-13	43.51

***** INPUT LINE 6 RP 0 10 10 1002 0.00000E+00 0.00000E+00 1.00000E+01 1.00000E+01 0.00000E+00 0.00000E+00

--- RADIATION PATTERNS ---

-- ANGLES --		- POWER GAINS -			--- POLARIZATION ---			--- E(THETA) ---		--- E(PHI) ---	
THETA DEGREES	PHI DEGREES	VERT. DB	HOR. DB	TOTAL DB	AXIAL RATIO	TILT DEG.	SENSE	MAGNITUDE VOLTS	PHASE DEGREES	MAGNITUDE VOLTS	PHASE DEGREES

AVERAGE POWER GAIN= 1.18046E-03 SOLID ANGLE USED IN AVERAGING=(0.5000)*PI STERADIANS.

POWER RADIATED ASSUMING RADIATION INTO 4*PI STERADIANS = 2.11475E-06 WATTS

***** INPUT LINE 7 EN 0 0 0 0 0.00000E+00 0.00000E+00 0.00000E+00 0.00000E+00 0.00000E+00 0.00000E+00

RUN TIME = 7.350

4.2.7 Example 11, Monopole Antenna on a Ground Stake

In example 11, a 15 m monopole is modeled on a ground stake 2 m deep. Separate GW commands are used to define the monopole and ground stake to ensure that the junction will occur exactly at the interface. The average gain computation shows that the radiation efficiency of this antenna over ground is 16 percent. NE and NH commands are used to compute the electric and magnetic fields at a distance of 5000 m with the surface wave included. When the Sommerfeld ground option is in use, the near magnetic field is computed from a finite-difference evaluation of $\nabla \times \mathbf{E}$. The increment for evaluating differences is $\pm 10^{-3} \lambda_0$. Hence, if the near magnetic field had been evaluated at a height of less than 0.06 m in this example an incorrect value would have been obtained due to the negative increment in z falling on the wrong side of the interface.

If the lower medium had a conductivity of zero, the average gain could be computed over both upper and lower half spaces ($0^\circ \leq \theta \leq 180^\circ$) and should have a value of 1.0. This can serve as a necessary, but not sufficient, check on the solution accuracy for a dielectric ground. In integrating the power in a dielectric ground, it may be necessary to use increments in θ of a degree or less to accurately sample the field near the totally reflecting or critical angle in the ground ($\theta = 180^\circ - \sin^{-1} \epsilon^{-1/2} = 162^\circ$ for $\epsilon_r = 10$, $\sigma = 0$.) The steepness of this near discontinuity increases with increasing height of the antenna above the ground.

Input for Example 11

```

CM 15 m monopole antenna on a ground stake 2 m deep.
CE Ground: E = 10., SIG = 0.01 S/m, 5 MHz.
GW 1 8 0. 0. -2. 0. 0. 0. 0.01
GW 2 10 0. 0. 0. 0. 0. 15. 0.01
GE -1
FR 0 1 0 0 5.
GN 2 0 0 0 10. 0.01 SOMEX10.NEC
EX 0 2 1 0 1.
RP 0 19 2 1002 0. 0. 5. 90.
NE 0 1 1 21 5000. 0. 0.1 0. 0. 10.
NH 0 1 1 21 5000. 0. 0.1 0. 0. 10.
EN

```

Output for Example 11

```

*****
*
* NUMERICAL ELECTROMAGNETICS CODE (NEC-4.1)
*
*****
    
```

```

*****
15 m monopole antenna on a ground stake 2 m deep.
Ground: E = 10., SIG = 0.01 S/m, 5 MHz.
*****
    
```

- - - STRUCTURE SPECIFICATION - - -

COORDINATES MUST BE INPUT IN
METERS OR BE SCALED TO METERS
BEFORE STRUCTURE INPUT IS ENDED

WIRE NO.	X1	Y1	Z1	X2	Y2	Z2	RADIUS	NO. OF SEG.	FIRST SEG.	LAST SEG.	TAG NO.
1	0.00000	0.00000	-2.00000	0.00000	0.00000	0.00000	0.01000	8	1	8	1
2	0.00000	0.00000	0.00000	0.00000	0.00000	15.00000	0.01000	10	9	18	2

GROUND PLANE SPECIFIED.

TOTAL SEGMENTS USED= 18 NO. SEG. IN A SYMMETRIC CELL= 18 SYMMETRY FLAG= 0

- MULTIPLE WIRE JUNCTIONS -
JUNCTION SEGMENTS (- FOR END 1, + FOR END 2)
NONE

- - - - SEGMENTATION DATA - - - -

COORDINATES IN METERS

I+ AND I- INDICATE THE SEGMENTS BEFORE AND AFTER I

SEG. NO.	COORDINATES OF SEG. CENTER			SEG. LENGTH	ORIENTATION ANGLES		WIRE RADIUS	CONNECTION DATA			TAG NO.
	X	Y	Z		ALPHA	BETA		I-	I	I+	
1	0.00000	0.00000	-1.87500	0.25000	90.00000	0.00000	0.01000	0	1	2	1
2	0.00000	0.00000	-1.62500	0.25000	90.00000	0.00000	0.01000	1	2	3	1
3	0.00000	0.00000	-1.37500	0.25000	90.00000	0.00000	0.01000	2	3	4	1
4	0.00000	0.00000	-1.12500	0.25000	90.00000	0.00000	0.01000	3	4	5	1
5	0.00000	0.00000	-0.87500	0.25000	90.00000	0.00000	0.01000	4	5	6	1
6	0.00000	0.00000	-0.62500	0.25000	90.00000	0.00000	0.01000	5	6	7	1
7	0.00000	0.00000	-0.37500	0.25000	90.00000	0.00000	0.01000	6	7	8	1
8	0.00000	0.00000	-0.12500	0.25000	90.00000	0.00000	0.01000	7	8	9	1
9	0.00000	0.00000	0.75000	1.50000	90.00000	0.00000	0.01000	8	9	10	2
10	0.00000	0.00000	2.25000	1.50000	90.00000	0.00000	0.01000	9	10	11	2
11	0.00000	0.00000	3.75000	1.50000	90.00000	0.00000	0.01000	10	11	12	2
12	0.00000	0.00000	5.25000	1.50000	90.00000	0.00000	0.01000	11	12	13	2
13	0.00000	0.00000	6.75000	1.50000	90.00000	0.00000	0.01000	12	13	14	2
14	0.00000	0.00000	8.25000	1.50000	90.00000	0.00000	0.01000	13	14	15	2
15	0.00000	0.00000	9.75000	1.50000	90.00000	0.00000	0.01000	14	15	16	2
16	0.00000	0.00000	11.25000	1.50000	90.00000	0.00000	0.01000	15	16	17	2
17	0.00000	0.00000	12.75000	1.50000	90.00000	0.00000	0.01000	16	17	18	2
18	0.00000	0.00000	14.25000	1.50000	90.00000	0.00000	0.01000	17	18	0	2

```

***** INPUT LINE 1 FR 0 1 0 0 5.00000E+00 0.00000E+00 0.00000E+00 0.00000E+00 0.00000E+00 0.00000E+00
***** INPUT LINE 2 GN 2 0 0 0 1.00000E+01 1.00000E-02 0.00000E+00 0.00000E+00 0.00000E+00 0.00000E+00
***** INPUT LINE 3 EX 0 2 1 0 1.00000E+00 0.00000E+00 0.00000E+00 0.00000E+00 0.00000E+00 0.00000E+00
***** INPUT LINE 4 RP 0 19 2 1002 0.00000E+00 0.00000E+00 5.00000E+00 9.00000E+01 0.00000E+00 0.00000E+00

```

----- FREQUENCY -----

FREQUENCY= 5.0000E+00 MHZ
WAVELENGTH= 5.9960E+01 METERS

----- ANTENNA ENVIRONMENT -----

GNDINO: UNABLE TO OPEN FILE SOMEX10.NEC
WILL COMPUTE SOMMERFELD-GROUND TABLES

Time to generate Sommerfeld ground tables = 6.23 seconds

FINITE GROUND. SOMMERFELD SOLUTION
RELATIVE DIELECTRIC CONST.= 10.000
CONDUCTIVITY= 1.000E-02 MHOS/METER
COMPLEX DIELECTRIC CONSTANT= 1.00000E+01-3.59510E+01

----- STRUCTURE IMPEDANCE LOADING -----

THIS STRUCTURE IS NOT LOADED

----- MATRIX TIMING -----

FILL= 0.120 SEC., FACTOR= 0.000 SEC.

----- ANTENNA INPUT PARAMETERS -----

TAG NO.	SEG. NO.	VOLTAGE (VOLTS)		CURRENT (AMPS)		IMPEDANCE (OHMS)		ADMITTANCE (MHOS)		POWER (WATTS)
		REAL	IMAG.	REAL	IMAG.	REAL	IMAG.	REAL	IMAG.	
2	9	1.00000E+00	0.00000E+00	8.92874E-03	-3.54528E-03	9.67451E+01	3.84140E+01	8.92874E-03	-3.54528E-03	4.46437E-03

----- CURRENTS AND LOCATION -----

LENGTHS NORMALIZED BY WAVELENGTH (OR 2.*PI/CABS(K))

SEG. NO.	TAG NO.	COORD. OF SEG. CENTER			SEG. LENGTH	CURRENT (AMPS)			PHASE
		X	Y	Z		REAL	IMAG.	MAG.	
1	1	0.0000	0.0000	-0.1910	0.02547	6.8675E-04	-5.9400E-04	9.0800E-04	-40.858
2	1	0.0000	0.0000	-0.1656	0.02547	1.7691E-03	-1.4821E-03	2.3079E-03	-39.956
3	1	0.0000	0.0000	-0.1401	0.02547	2.7892E-03	-2.2227E-03	3.5665E-03	-38.552
4	1	0.0000	0.0000	-0.1146	0.02547	3.8210E-03	-2.8439E-03	4.7632E-03	-36.660
5	1	0.0000	0.0000	-0.0891	0.02547	4.8850E-03	-3.3287E-03	5.9113E-03	-34.271
6	1	0.0000	0.0000	-0.0637	0.02547	5.9915E-03	-3.6544E-03	7.0180E-03	-31.380
7	1	0.0000	0.0000	-0.0382	0.02547	7.1442E-03	-3.7957E-03	8.0899E-03	-27.982
8	1	0.0000	0.0000	-0.0127	0.02547	8.3406E-03	-3.7251E-03	9.1347E-03	-24.067
9	2	0.0000	0.0000	0.0125	0.02502	8.9287E-03	-3.5453E-03	9.6068E-03	-21.656
10	2	0.0000	0.0000	0.0375	0.02502	8.7241E-03	-3.6492E-03	9.4566E-03	-22.699
11	2	0.0000	0.0000	0.0625	0.02502	8.3168E-03	-3.6496E-03	9.0824E-03	-23.693
12	2	0.0000	0.0000	0.0876	0.02502	7.7163E-03	-3.5108E-03	8.4775E-03	-24.465
13	2	0.0000	0.0000	0.1126	0.02502	6.9354E-03	-3.2498E-03	7.6591E-03	-25.107
14	2	0.0000	0.0000	0.1376	0.02502	5.9899E-03	-2.8776E-03	6.6453E-03	-25.660
15	2	0.0000	0.0000	0.1626	0.02502	4.8976E-03	-2.4045E-03	5.4560E-03	-26.149
16	2	0.0000	0.0000	0.1876	0.02502	3.6769E-03	-1.8404E-03	4.1117E-03	-26.590
17	2	0.0000	0.0000	0.2126	0.02502	2.3412E-03	-1.1926E-03	2.6275E-03	-26.994
18	2	0.0000	0.0000	0.2377	0.02502	8.6185E-04	-4.4611E-04	9.7046E-04	-27.367

--- POWER BUDGET ---

INPUT POWER = 4.4644E-03 WATTS
 RADIATED POWER= 4.4644E-03 WATTS
 WIRE LOSS = 0.0000E+00 WATTS
 EFFICIENCY = 100.00 PERCENT

--- RADIATION PATTERNS ---

-- ANGLES --		- POWER GAINS -			--- POLARIZATION ---			--- E(THETA) ---		--- E(PHI) ---	
THETA	PHI	VERT.	HOR.	TOTAL	AXIAL	TILT	SENSE	MAGNITUDE	PHASE	MAGNITUDE	PHASE
DEGREES	DEGREES	DB	DB	DB	RATIO	DEG.		VOLTS	DEGREES	VOLTS	DEGREES

AVERAGE POWER GAIN= 3.21452E-01 SOLID ANGLE USED IN AVERAGING=(0.5000)*PI STERADIANS.

POWER RADIATED ASSUMING RADIATION INTO 4*PI STERADIANS = 1.43508E-03 WATTS

***** INPUT LINE 5 NE 0 1 1 21 5.00000E+03 0.00000E+00 1.00000E-01 0.00000E+00 0.00000E+00 1.00000E+01

--- NEAR ELECTRIC FIELDS ---

- LOCATION -			- EX -		- EY -		- EZ -	
X	Y	Z	MAGNITUDE	PHASE	MAGNITUDE	PHASE	MAGNITUDE	PHASE
METERS	METERS	METERS	VOLTS/M	DEGREES	VOLTS/M	DEGREES	VOLTS/M	DEGREES
5000.0000	0.0000	0.1000	1.7186E-06	-8.43	3.4802E-12	169.38	1.0535E-05	-44.97
5000.0000	0.0000	10.1000	1.6544E-06	-7.42	3.2555E-12	174.13	9.5768E-06	-36.49
5000.0000	0.0000	20.1000	1.5924E-06	-6.77	3.0579E-12	179.11	8.8692E-06	-26.85
5000.0000	0.0000	30.1000	1.5323E-06	-6.47	2.8876E-12	-175.70	8.4462E-06	-16.37
5000.0000	0.0000	40.1000	1.4738E-06	-6.55	2.7448E-12	-170.35	8.3249E-06	-5.61
5000.0000	0.0000	50.1000	1.4170E-06	-7.02	2.6294E-12	-164.88	8.4940E-06	4.66
5000.0000	0.0000	60.1000	1.3618E-06	-7.91	2.5408E-12	-159.37	8.9160E-06	13.85
5000.0000	0.0000	70.1000	1.3084E-06	-9.24	2.4779E-12	-153.92	9.5391E-06	21.64
5000.0000	0.0000	80.1000	1.2569E-06	-11.03	2.4389E-12	-148.63	1.0311E-05	28.00
5000.0000	0.0000	90.1000	1.2078E-06	-13.31	2.4219E-12	-143.58	1.1189E-05	33.06
5000.0000	0.0000	100.1000	1.1615E-06	-16.10	2.4242E-12	-138.87	1.2137E-05	37.00
5000.0000	0.0000	110.1000	1.1185E-06	-19.43	2.4432E-12	-134.55	1.3130E-05	40.00
5000.0000	0.0000	120.1000	1.0798E-06	-23.31	2.4763E-12	-130.66	1.4152E-05	42.23
5000.0000	0.0000	130.1000	1.0490E-06	-27.59	2.5275E-12	-127.34	1.5199E-05	43.73
5000.0000	0.0000	140.1000	1.0214E-06	-32.52	2.5825E-12	-124.38	1.6244E-05	44.76
5000.0000	0.0000	150.1000	9.9950E-07	-38.06	2.6413E-12	-121.82	1.7282E-05	45.36
5000.0000	0.0000	160.1000	9.8573E-07	-44.08	2.7053E-12	-119.69	1.8315E-05	45.56
5000.0000	0.0000	170.1000	9.8094E-07	-50.49	2.7730E-12	-117.96	1.9339E-05	45.41
5000.0000	0.0000	180.1000	9.8582E-07	-57.19	2.8431E-12	-116.61	2.0351E-05	44.94
5000.0000	0.0000	190.1000	1.0008E-06	-64.06	2.9144E-12	-115.61	2.1350E-05	44.19
5000.0000	0.0000	200.1000	1.0261E-06	-70.98	2.9861E-12	-114.94	2.2334E-05	43.18

***** INPUT LINE 6 NH 0 1 1 21 5.00000E+03 0.00000E+00 1.00000E-01 0.00000E+00 0.00000E+00 1.00000E+01

--- NEAR MAGNETIC FIELDS ---

- LOCATION -			- HX -		- HY -		- HZ -	
X	Y	Z	MAGNITUDE	PHASE	MAGNITUDE	PHASE	MAGNITUDE	PHASE
METERS	METERS	METERS	AMPS/M	DEGREES	AMPS/M	DEGREES	AMPS/M	DEGREES
5000.0000	0.0000	0.1000	9.3545E-16	-150.48	2.7949E-08	135.16	9.2426E-15	169.13
5000.0000	0.0000	10.1000	8.8181E-16	-148.50	2.5408E-08	143.65	8.6459E-15	173.89
5000.0000	0.0000	20.1000	8.3067E-16	-146.75	2.3532E-08	153.28	8.1209E-15	178.87
5000.0000	0.0000	30.1000	7.8174E-16	-145.22	2.2411E-08	163.77	7.6686E-15	-175.94
5000.0000	0.0000	40.1000	7.3481E-16	-143.94	2.2090E-08	174.52	7.2893E-15	-170.58
5000.0000	0.0000	50.1000	6.8967E-16	-142.91	2.2540E-08	-175.21	6.9827E-15	-165.11
5000.0000	0.0000	60.1000	6.4614E-16	-142.15	2.3661E-08	-166.02	6.7472E-15	-159.60
5000.0000	0.0000	70.1000	6.0409E-16	-141.67	2.5316E-08	-158.23	6.5799E-15	-154.15
5000.0000	0.0000	80.1000	5.6340E-16	-141.50	2.7367E-08	-151.88	6.4764E-15	-148.85
5000.0000	0.0000	90.1000	5.2400E-16	-141.66	2.9696E-08	-146.82	6.4308E-15	-143.80
5000.0000	0.0000	100.1000	4.8582E-16	-142.19	3.2214E-08	-142.89	6.4368E-15	-139.09
5000.0000	0.0000	110.1000	4.4885E-16	-143.12	3.4852E-08	-139.88	6.4869E-15	-134.76

5000.0000	0.0000	120.1000	4.1315E-16	-144.50	3.7565E-08	-137.66	6.5745E-15	-130.87
5000.0000	0.0000	130.1000	4.6553E-16	160.10	4.0263E-08	-136.41	6.7103E-15	-127.55
5000.0000	0.0000	140.1000	3.4721E-16	-148.31	4.3124E-08	-135.13	6.8561E-15	-124.59
5000.0000	0.0000	150.1000	3.1512E-16	-151.56	4.5883E-08	-134.53	7.0119E-15	-122.02
5000.0000	0.0000	160.1000	2.8497E-16	-155.68	4.8627E-08	-134.33	7.1816E-15	-119.89
5000.0000	0.0000	170.1000	2.5713E-16	-160.83	5.1348E-08	-134.49	7.3611E-15	-118.15
5000.0000	0.0000	180.1000	2.3217E-16	-167.23	5.4039E-08	-134.96	7.5467E-15	-116.80
5000.0000	0.0000	190.1000	2.1082E-16	-175.04	5.6695E-08	-135.71	7.7357E-15	-115.79
5000.0000	0.0000	200.1000	1.9400E-16	175.62	5.9312E-08	-136.73	7.9257E-15	-115.12

***** INPUT LINE 7 EN 0 0 0 0 0.00000E+00 0.00000E+00 0.00000E+00 0.00000E+00 0.00000E+00 0.00000E+00

RUN TIME = 7.400

4.2.8 Example 12, Monopole Antenna on a Radial-Wire Ground Screen

The monopole antenna from Example 11 is now modeled on a ground screen of six radial wires, with a screen radius of 12 meters. The Numerical Green's Function option was used to take advantage of the rotational symmetry of the ground screen. The monopole is added on the axis of rotation in the second part of the run.

The screen was buried 5 cm below the surface of the ground. Since a segment cannot penetrate the interface, the junction of the monopole and the radial wires was located on the interface at the origin. The inner segment of each radial wire descends at an angle to the 5 cm depth, and the remainder of the radial is horizontal. The inner segment was chosen to have approximately the same length as the horizontal segments. The complete ground screen is generated with a GR command to set the code to use symmetry in the solution.

The monopole is added to the NGF solution in the second part of the run. The summary of segment data includes all segments from the NGF file and those added for the monopole. After the summary of segment data, a line shows the number of new unknowns in the NGF solution. This number includes the new segments plus one new unknown for each segment from the NGF file that connects to a new segment. Segments in the NGF file that connect to new segments contribute new unknowns since they need new basis functions due to the changed junction condition. Since there are 10 segments in the monopole and six radials each connecting to the base of the monopole, the number of new unknowns is 16. The code must also recompute the field from the second ring of segments from the center of the screen, since the basis functions for the first segments extend onto the second segments. This additional integration can significantly reduce the advantage of using the NGF to take advantage of symmetry when many NGF segments connect to new segments.

The computed results include a radiation pattern and average gain. From the average gain, it is seen that the radiation efficiency has increased to 29 percent from the 16 percent obtained with a ground stake. A better ground screen would increase the efficiency still further. The NEC-GS program is much more efficient than NEC-4 [11] for modeling monopoles on large radial-wire ground screens. However, at the present time there no version of NEC-GS using the NEC-4 solution algorithms.

Input for Example 12

```
CM 6-Wire Radial-Wire Ground Screen.
CE An NGF file is written to take advantage of symmetry of the screen.
GW 1 14 12. 0. -.05 0.8 0. -.05 .01
GW 1 1 0.8 0. -.05 0. 0. 0. .01
GR 0 6
GE
FR 0 1 0 0 5.
GN 2 0 0 0 10. .01 SOMEX10.NEC
WG
NK
CE 15 m Monopole added to the ground screen from the NGF file.
GF
GW 2 10 0. 0. 0. 0. 0. 15. .01
GE
EX 0 2 1 0 1.
RP 0 19 2 1001 0. 0. 5. 90.
EN
```

Output for Example 12

```

*****
*
* NUMERICAL ELECTROMAGNETICS CODE (NEC-4.1)
*
*****
    
```

```

*****
6-Wire Radial-Wire Ground Screen.
An NGF file is written to take advantage of symmetry of the screen.
*****
    
```

- - - STRUCTURE SPECIFICATION - - -

COORDINATES MUST BE INPUT IN
METERS OR BE SCALED TO METERS
BEFORE STRUCTURE INPUT IS ENDED

WIRE NO.	X1	Y1	Z1	X2	Y2	Z2	RADIUS	NO. OF SEG.	FIRST SEG.	LAST SEG.	TAG NO.
1	12.00000	0.00000	-0.05000	0.80000	0.00000	-0.05000	0.01000	14	1	14	1
2	0.80000	0.00000	-0.05000	0.00000	0.00000	0.00000	0.01000	1	15	15	1

STRUCTURE ROTATED ABOUT Z-AXIS 6 TIMES. LABELS INCREMENTED BY 0

TOTAL SEGMENTS USED= 90 NO. SEG. IN A SYMMETRIC CELL= 15 SYMMETRY FLAG= -1
STRUCTURE HAS 6 FOLD ROTATIONAL SYMMETRY

- MULTIPLE WIRE JUNCTIONS -
JUNCTION SEGMENTS (- FOR END 1, + FOR END 2)

1	15	30	45	60	75	90
---	----	----	----	----	----	----

- - - - SEGMENTATION DATA - - - -

COORDINATES IN METERS

I+ AND I- INDICATE THE SEGMENTS BEFORE AND AFTER I

SEG. NO.	COORDINATES OF SEG. CENTER			SEG. LENGTH	ORIENTATION ANGLES		WIRE RADIUS	CONNECTION DATA			TAG NO.
	X	Y	Z		ALPHA	BETA		I-	I	I+	
1	11.60000	0.00000	-0.05000	0.80000	0.00000	180.00000	0.01000	0	1	2	1
2	10.80000	0.00000	-0.05000	0.80000	0.00000	180.00000	0.01000	1	2	3	1
3	10.00000	0.00000	-0.05000	0.80000	0.00000	180.00000	0.01000	2	3	4	1
4	9.20000	0.00000	-0.05000	0.80000	0.00000	180.00000	0.01000	3	4	5	1
5	8.40000	0.00000	-0.05000	0.80000	0.00000	180.00000	0.01000	4	5	6	1
6	7.60000	0.00000	-0.05000	0.80000	0.00000	180.00000	0.01000	5	6	7	1
7	6.80000	0.00000	-0.05000	0.80000	0.00000	180.00000	0.01000	6	7	8	1
8	6.00000	0.00000	-0.05000	0.80000	0.00000	180.00000	0.01000	7	8	9	1
9	5.20000	0.00000	-0.05000	0.80000	0.00000	180.00000	0.01000	8	9	10	1
10	4.40000	0.00000	-0.05000	0.80000	0.00000	180.00000	0.01000	9	10	11	1
11	3.60000	0.00000	-0.05000	0.80000	0.00000	180.00000	0.01000	10	11	12	1
12	2.80000	0.00000	-0.05000	0.80000	0.00000	180.00000	0.01000	11	12	13	1
13	2.00000	0.00000	-0.05000	0.80000	0.00000	180.00000	0.01000	12	13	14	1
14	1.20000	0.00000	-0.05000	0.80000	0.00000	180.00000	0.01000	13	14	15	1
15	0.40000	0.00000	-0.02500	0.80156	3.57633	180.00000	0.01000	14	15	-30	1
16	5.80000	10.04589	-0.05000	0.80000	0.00000	-120.00000	0.01000	0	16	17	1
17	5.40000	9.35307	-0.05000	0.80000	0.00000	-120.00000	0.01000	16	17	18	1
18	5.00000	8.66025	-0.05000	0.80000	0.00000	-120.00000	0.01000	17	18	19	1
19	4.60000	7.96743	-0.05000	0.80000	0.00000	-120.00000	0.01000	18	19	20	1

20	4.20000	7.27461	-0.05000	0.80000	0.00000	-120.00000	0.01000	19	20	21	1
21	3.80000	6.58179	-0.05000	0.80000	0.00000	-120.00000	0.01000	20	21	22	1
22	3.40000	5.88897	-0.05000	0.80000	0.00000	-120.00000	0.01000	21	22	23	1
23	3.00000	5.19615	-0.05000	0.80000	0.00000	-120.00000	0.01000	22	23	24	1
24	2.60000	4.50333	-0.05000	0.80000	0.00000	-120.00000	0.01000	23	24	25	1
25	2.20000	3.81051	-0.05000	0.80000	0.00000	-120.00000	0.01000	24	25	26	1
26	1.80000	3.11769	-0.05000	0.80000	0.00000	-120.00000	0.01000	25	26	27	1
27	1.40000	2.42487	-0.05000	0.80000	0.00000	-120.00000	0.01000	26	27	28	1
28	1.00000	1.73205	-0.05000	0.80000	0.00000	-120.00000	0.01000	27	28	29	1
29	0.60000	1.03923	-0.05000	0.80000	0.00000	-120.00000	0.01000	28	29	30	1
30	0.20000	0.34641	-0.02500	0.80156	3.57633	-120.00000	0.01000	29	30	-45	1
31	-5.80000	10.04589	-0.05000	0.80000	0.00000	-60.00000	0.01000	0	31	32	1
32	-5.40000	9.35307	-0.05000	0.80000	0.00000	-60.00000	0.01000	31	32	33	1
33	-5.00000	8.66025	-0.05000	0.80000	0.00000	-60.00000	0.01000	32	33	34	1
34	-4.60000	7.96743	-0.05000	0.80000	0.00000	-60.00000	0.01000	33	34	35	1
35	-4.20000	7.27461	-0.05000	0.80000	0.00000	-60.00000	0.01000	34	35	36	1
36	-3.80000	6.58179	-0.05000	0.80000	0.00000	-60.00000	0.01000	35	36	37	1
37	-3.40000	5.88897	-0.05000	0.80000	0.00000	-60.00000	0.01000	36	37	38	1
38	-3.00000	5.19615	-0.05000	0.80000	0.00000	-60.00000	0.01000	37	38	39	1
39	-2.60000	4.50333	-0.05000	0.80000	0.00000	-60.00000	0.01000	38	39	40	1
40	-2.20000	3.81051	-0.05000	0.80000	0.00000	-60.00000	0.01000	39	40	41	1
41	-1.80000	3.11769	-0.05000	0.80000	0.00000	-60.00000	0.01000	40	41	42	1
42	-1.40000	2.42487	-0.05000	0.80000	0.00000	-60.00000	0.01000	41	42	43	1
43	-1.00000	1.73205	-0.05000	0.80000	0.00000	-60.00000	0.01000	42	43	44	1
44	-0.60000	1.03923	-0.05000	0.80000	0.00000	-60.00000	0.01000	43	44	45	1
45	-0.20000	0.34641	-0.02500	0.80156	3.57633	-60.00000	0.01000	44	45	-60	1
46	-11.60000	0.00000	-0.05000	0.80000	0.00000	0.00000	0.01000	0	46	47	1
47	-10.80000	0.00000	-0.05000	0.80000	0.00000	0.00000	0.01000	46	47	48	1
48	-10.00000	0.00000	-0.05000	0.80000	0.00000	0.00000	0.01000	47	48	49	1
49	-9.20000	0.00000	-0.05000	0.80000	0.00000	0.00000	0.01000	48	49	50	1
50	-8.40000	0.00000	-0.05000	0.80000	0.00000	0.00000	0.01000	49	50	51	1
51	-7.60000	0.00000	-0.05000	0.80000	0.00000	0.00000	0.01000	50	51	52	1
52	-6.80000	0.00000	-0.05000	0.80000	0.00000	0.00000	0.01000	51	52	53	1
53	-6.00000	0.00000	-0.05000	0.80000	0.00000	0.00000	0.01000	52	53	54	1
54	-5.20000	0.00000	-0.05000	0.80000	0.00000	0.00000	0.01000	53	54	55	1
55	-4.40000	0.00000	-0.05000	0.80000	0.00000	0.00000	0.01000	54	55	56	1
56	-3.60000	0.00000	-0.05000	0.80000	0.00000	0.00000	0.01000	55	56	57	1
57	-2.80000	0.00000	-0.05000	0.80000	0.00000	0.00000	0.01000	56	57	58	1
58	-2.00000	0.00000	-0.05000	0.80000	0.00000	0.00000	0.01000	57	58	59	1
59	-1.20000	0.00000	-0.05000	0.80000	0.00000	0.00000	0.01000	58	59	60	1
60	-0.40000	0.00000	-0.02500	0.80156	3.57633	0.00000	0.01000	59	60	-75	1
61	-5.80000	-10.04589	-0.05000	0.80000	0.00000	60.00000	0.01000	0	61	62	1
62	-5.40000	-9.35307	-0.05000	0.80000	0.00000	60.00000	0.01000	61	62	63	1
63	-5.00000	-8.66025	-0.05000	0.80000	0.00000	60.00000	0.01000	62	63	64	1
64	-4.60000	-7.96743	-0.05000	0.80000	0.00000	60.00000	0.01000	63	64	65	1
65	-4.20000	-7.27461	-0.05000	0.80000	0.00000	60.00000	0.01000	64	65	66	1
66	-3.80000	-6.58179	-0.05000	0.80000	0.00000	60.00000	0.01000	65	66	67	1
67	-3.40000	-5.88897	-0.05000	0.80000	0.00000	60.00000	0.01000	66	67	68	1
68	-3.00000	-5.19615	-0.05000	0.80000	0.00000	60.00000	0.01000	67	68	69	1
69	-2.60000	-4.50333	-0.05000	0.80000	0.00000	60.00000	0.01000	68	69	70	1
70	-2.20000	-3.81051	-0.05000	0.80000	0.00000	60.00000	0.01000	69	70	71	1
71	-1.80000	-3.11769	-0.05000	0.80000	0.00000	60.00000	0.01000	70	71	72	1
72	-1.40000	-2.42487	-0.05000	0.80000	0.00000	60.00000	0.01000	71	72	73	1
73	-1.00000	-1.73205	-0.05000	0.80000	0.00000	60.00000	0.01000	72	73	74	1
74	-0.60000	-1.03923	-0.05000	0.80000	0.00000	60.00000	0.01000	73	74	75	1
75	-0.20000	-0.34641	-0.02500	0.80156	3.57633	60.00000	0.01000	74	75	-90	1
76	5.80000	-10.04589	-0.05000	0.80000	0.00000	120.00000	0.01000	0	76	77	1
77	5.40000	-9.35307	-0.05000	0.80000	0.00000	120.00000	0.01000	76	77	78	1
78	5.00000	-8.66025	-0.05000	0.80000	0.00000	120.00000	0.01000	77	78	79	1
79	4.60000	-7.96743	-0.05000	0.80000	0.00000	120.00000	0.01000	78	79	80	1
80	4.20000	-7.27461	-0.05000	0.80000	0.00000	120.00000	0.01000	79	80	81	1
81	3.80000	-6.58179	-0.05000	0.80000	0.00000	120.00000	0.01000	80	81	82	1
82	3.40000	-5.88897	-0.05000	0.80000	0.00000	120.00000	0.01000	81	82	83	1
83	3.00000	-5.19615	-0.05000	0.80000	0.00000	120.00000	0.01000	82	83	84	1
84	2.60000	-4.50333	-0.05000	0.80000	0.00000	120.00000	0.01000	83	84	85	1
85	2.20000	-3.81051	-0.05000	0.80000	0.00000	120.00000	0.01000	84	85	86	1
86	1.80000	-3.11769	-0.05000	0.80000	0.00000	120.00000	0.01000	85	86	87	1
87	1.40000	-2.42487	-0.05000	0.80000	0.00000	120.00000	0.01000	86	87	88	1
88	1.00000	-1.73205	-0.05000	0.80000	0.00000	120.00000	0.01000	87	88	89	1
89	0.60000	-1.03923	-0.05000	0.80000	0.00000	120.00000	0.01000	88	89	90	1
90	0.20000	-0.34641	-0.02500	0.80156	3.57633	120.00000	0.01000	89	90	-15	1

***** INPUT LINE 1 FR 0 1 0 0 5.00000E+00 0.00000E+00 0.00000E+00 0.00000E+00 0.00000E+00 0.00000E+00

***** INPUT LINE 2 GN 2 0 0 0 1.00000E+01 1.00000E-02 0.00000E+00 0.00000E+00 0.00000E+00 0.00000E+00

***** INPUT LINE 3 WG 0 0 0 0 0.00000E+00 0.00000E+00 SOMEX10.NEC 0.00000E+00 0.00000E+00 0.00000E+00 0.00000E+00

- - - - - FREQUENCY - - - - -

FREQUENCY= 5.0000E+00 MHZ
WAVELENGTH= 5.9960E+01 METERS

- - - ANTENNA ENVIRONMENT - - -

FINITE GROUND. SOMMERFELD SOLUTION
RELATIVE DIELECTRIC CONST.= 10.000
CONDUCTIVITY= 1.000E-02 MHOS/METER
COMPLEX DIELECTRIC CONSTANT= 1.00000E+01-3.59510E+01

- - - STRUCTURE IMPEDANCE LOADING - - -

THIS STRUCTURE IS NOT LOADED

- - - MATRIX TIMING - - -

FILL= 0.690 SEC., FACTOR= 0.000 SEC.

***NUMERICAL GREEN'S FUNCTION WRITTEN ON FILE NGFD.NEC
MATRIX STORAGE - 1350 COMPLEX NUMBERS

***** INPUT LINE 4 NX 0 0 0 0 0.00000E+00 0.00000E+00 0.00000E+00 0.00000E+00 0.00000E+00 0.00000E+00

```

*****
*
*   NUMERICAL ELECTROMAGNETICS CODE (NEC-4.1)
*
*****

```

```

*****
15 m Monopole added to the ground screen from the NGF file.
*****

```

```

*****
**
** NUMERICAL GREEN'S FUNCTION FILE
** NO. SEGMENTS = 90      NO. PATCHES = 0
** NO. SYMMETRIC SECTIONS = 6
** N.G.F. MATRIX - CORE STORAGE = 1350 COMPLEX NUMBERS, CASE 2
** FREQUENCY = 5.00000E+00 MHZ.
** FINITE GROUND. SOMMERFELD SOLUTION
** GROUND PARAMETERS - DIELECTRIC CONSTANT = 1.00000E+01
**                      CONDUCTIVITY = 1.00000E-02 MHOS/M.
**
** 6-Wire Radial-Wire Ground Screen.
** An NGF file is written to take advantage of symmetry of the screen.
**
*****

```

- - - STRUCTURE SPECIFICATION - - -

COORDINATES MUST BE INPUT IN METERS OR BE SCALED TO METERS BEFORE STRUCTURE INPUT IS ENDED

WIRE NO.	X1	Y1	Z1	X2	Y2	Z2	RADIUS	NO. OF SEG.	FIRST SEG.	LAST SEG.	TAG NO.
1	0.00000	0.00000	0.00000	0.00000	0.00000	15.00000	0.01000	10	91	100	2

TOTAL SEGMENTS USED= 100 NO. SEG. IN A SYMMETRIC CELL= 100 SYMMETRY FLAG= 0

- MULTIPLE WIRE JUNCTIONS -
JUNCTION SEGMENTS (- FOR END 1, + FOR END 2)
1 15 30 45 60 75 90 -91

- - - SEGMENTATION DATA - - -

COORDINATES IN METERS

I+ AND I- INDICATE THE SEGMENTS BEFORE AND AFTER I

SEG. NO.	COORDINATES OF SEG. CENTER			SEG. LENGTH	ORIENTATION ANGLES		WIRE RADIUS	CONNECTION DATA			TAG NO.
	X	Y	Z		ALPHA	BETA		I-	I	I+	
1	11.60000	0.00000	-0.05000	0.80000	0.00000	180.00000	0.01000	0	1	2	1
2	10.80000	0.00000	-0.05000	0.80000	0.00000	180.00000	0.01000	1	2	3	1
3	10.00000	0.00000	-0.05000	0.80000	0.00000	180.00000	0.01000	2	3	4	1
4	9.20000	0.00000	-0.05000	0.80000	0.00000	180.00000	0.01000	3	4	5	1

5	8.40000	0.00000	-0.05000	0.80000	0.00000	180.00000	0.01000	4	5	6	1
6	7.60000	0.00000	-0.05000	0.80000	0.00000	180.00000	0.01000	5	6	7	1
7	6.80000	0.00000	-0.05000	0.80000	0.00000	180.00000	0.01000	6	7	8	1
8	6.00000	0.00000	-0.05000	0.80000	0.00000	180.00000	0.01000	7	8	9	1
9	5.20000	0.00000	-0.05000	0.80000	0.00000	180.00000	0.01000	8	9	10	1
10	4.40000	0.00000	-0.05000	0.80000	0.00000	180.00000	0.01000	9	10	11	1
11	3.60000	0.00000	-0.05000	0.80000	0.00000	180.00000	0.01000	10	11	12	1
12	2.80000	0.00000	-0.05000	0.80000	0.00000	180.00000	0.01000	11	12	13	1
13	2.00000	0.00000	-0.05000	0.80000	0.00000	180.00000	0.01000	12	13	14	1
14	1.20000	0.00000	-0.05000	0.80000	0.00000	180.00000	0.01000	13	14	15	1
15	0.40000	0.00000	-0.02500	0.80156	3.57633	180.00000	0.01000	14	15	-30	1
16	5.80000	10.04589	-0.05000	0.80000	0.00000	-120.00000	0.01000	0	16	17	1
17	5.40000	9.35307	-0.05000	0.80000	0.00000	-120.00000	0.01000	16	17	18	1
18	5.00000	8.66025	-0.05000	0.80000	0.00000	-120.00000	0.01000	17	18	19	1
19	4.60000	7.96743	-0.05000	0.80000	0.00000	-120.00000	0.01000	18	19	20	1
20	4.20000	7.27461	-0.05000	0.80000	0.00000	-120.00000	0.01000	19	20	21	1
21	3.80000	6.58179	-0.05000	0.80000	0.00000	-120.00000	0.01000	20	21	22	1
22	3.40000	5.88897	-0.05000	0.80000	0.00000	-120.00000	0.01000	21	22	23	1
23	3.00000	5.19615	-0.05000	0.80000	0.00000	-120.00000	0.01000	22	23	24	1
24	2.60000	4.50333	-0.05000	0.80000	0.00000	-120.00000	0.01000	23	24	25	1
25	2.20000	3.81051	-0.05000	0.80000	0.00000	-120.00000	0.01000	24	25	26	1
26	1.80000	3.11769	-0.05000	0.80000	0.00000	-120.00000	0.01000	25	26	27	1
27	1.40000	2.42487	-0.05000	0.80000	0.00000	-120.00000	0.01000	26	27	28	1
28	1.00000	1.73205	-0.05000	0.80000	0.00000	-120.00000	0.01000	27	28	29	1
29	0.60000	1.03923	-0.05000	0.80000	0.00000	-120.00000	0.01000	28	29	30	1
30	0.20000	0.34641	-0.02500	0.80156	3.57633	-120.00000	0.01000	29	30	-45	1
31	-5.80000	10.04589	-0.05000	0.80000	0.00000	-60.00000	0.01000	0	31	32	1
32	-5.40000	9.35307	-0.05000	0.80000	0.00000	-60.00000	0.01000	31	32	33	1
33	-5.00000	8.66025	-0.05000	0.80000	0.00000	-60.00000	0.01000	32	33	34	1
34	-4.60000	7.96743	-0.05000	0.80000	0.00000	-60.00000	0.01000	33	34	35	1
35	-4.20000	7.27461	-0.05000	0.80000	0.00000	-60.00000	0.01000	34	35	36	1
36	-3.80000	6.58179	-0.05000	0.80000	0.00000	-60.00000	0.01000	35	36	37	1
37	-3.40000	5.88897	-0.05000	0.80000	0.00000	-60.00000	0.01000	36	37	38	1
38	-3.00000	5.19615	-0.05000	0.80000	0.00000	-60.00000	0.01000	37	38	39	1
39	-2.60000	4.50333	-0.05000	0.80000	0.00000	-60.00000	0.01000	38	39	40	1
40	-2.20000	3.81051	-0.05000	0.80000	0.00000	-60.00000	0.01000	39	40	41	1
41	-1.80000	3.11769	-0.05000	0.80000	0.00000	-60.00000	0.01000	40	41	42	1
42	-1.40000	2.42487	-0.05000	0.80000	0.00000	-60.00000	0.01000	41	42	43	1
43	-1.00000	1.73205	-0.05000	0.80000	0.00000	-60.00000	0.01000	42	43	44	1
44	-0.60000	1.03923	-0.05000	0.80000	0.00000	-60.00000	0.01000	43	44	45	1
45	-0.20000	0.34641	-0.02500	0.80156	3.57633	-60.00000	0.01000	44	45	-60	1
46	-11.60000	0.00000	-0.05000	0.80000	0.00000	0.00000	0.01000	0	46	47	1
47	-10.80000	0.00000	-0.05000	0.80000	0.00000	0.00000	0.01000	46	47	48	1
48	-10.00000	0.00000	-0.05000	0.80000	0.00000	0.00000	0.01000	47	48	49	1
49	-9.20000	0.00000	-0.05000	0.80000	0.00000	0.00000	0.01000	48	49	50	1
50	-8.40000	0.00000	-0.05000	0.80000	0.00000	0.00000	0.01000	49	50	51	1
51	-7.60000	0.00000	-0.05000	0.80000	0.00000	0.00000	0.01000	50	51	52	1
52	-6.80000	0.00000	-0.05000	0.80000	0.00000	0.00000	0.01000	51	52	53	1
53	-6.00000	0.00000	-0.05000	0.80000	0.00000	0.00000	0.01000	52	53	54	1
54	-5.20000	0.00000	-0.05000	0.80000	0.00000	0.00000	0.01000	53	54	55	1
55	-4.40000	0.00000	-0.05000	0.80000	0.00000	0.00000	0.01000	54	55	56	1
56	-3.60000	0.00000	-0.05000	0.80000	0.00000	0.00000	0.01000	55	56	57	1
57	-2.80000	0.00000	-0.05000	0.80000	0.00000	0.00000	0.01000	56	57	58	1
58	-2.00000	0.00000	-0.05000	0.80000	0.00000	0.00000	0.01000	57	58	59	1
59	-1.20000	0.00000	-0.05000	0.80000	0.00000	0.00000	0.01000	58	59	60	1
60	-0.40000	0.00000	-0.02500	0.80156	3.57633	0.00000	0.01000	59	60	-75	1
61	-5.80000	-10.04589	-0.05000	0.80000	0.00000	60.00000	0.01000	0	61	62	1
62	-5.40000	-9.35307	-0.05000	0.80000	0.00000	60.00000	0.01000	61	62	63	1
63	-5.00000	-8.66025	-0.05000	0.80000	0.00000	60.00000	0.01000	62	63	64	1
64	-4.60000	-7.96743	-0.05000	0.80000	0.00000	60.00000	0.01000	63	64	65	1
65	-4.20000	-7.27461	-0.05000	0.80000	0.00000	60.00000	0.01000	64	65	66	1
66	-3.80000	-6.58179	-0.05000	0.80000	0.00000	60.00000	0.01000	65	66	67	1
67	-3.40000	-5.88897	-0.05000	0.80000	0.00000	60.00000	0.01000	66	67	68	1
68	-3.00000	-5.19615	-0.05000	0.80000	0.00000	60.00000	0.01000	67	68	69	1
69	-2.60000	-4.50333	-0.05000	0.80000	0.00000	60.00000	0.01000	68	69	70	1
70	-2.20000	-3.81051	-0.05000	0.80000	0.00000	60.00000	0.01000	69	70	71	1
71	-1.80000	-3.11769	-0.05000	0.80000	0.00000	60.00000	0.01000	70	71	72	1
72	-1.40000	-2.42487	-0.05000	0.80000	0.00000	60.00000	0.01000	71	72	73	1
73	-1.00000	-1.73205	-0.05000	0.80000	0.00000	60.00000	0.01000	72	73	74	1
74	-0.60000	-1.03923	-0.05000	0.80000	0.00000	60.00000	0.01000	73	74	75	1
75	-0.20000	-0.34641	-0.02500	0.80156	3.57633	60.00000	0.01000	74	75	-90	1
76	5.80000	-10.04589	-0.05000	0.80000	0.00000	120.00000	0.01000	0	76	77	1
77	5.40000	-9.35307	-0.05000	0.80000	0.00000	120.00000	0.01000	76	77	78	1
78	5.00000	-8.66025	-0.05000	0.80000	0.00000	120.00000	0.01000	77	78	79	1
79	4.60000	-7.96743	-0.05000	0.80000	0.00000	120.00000	0.01000	78	79	80	1
80	4.20000	-7.27461	-0.05000	0.80000	0.00000	120.00000	0.01000	79	80	81	1
81	3.80000	-6.58179	-0.05000	0.80000	0.00000	120.00000	0.01000	80	81	82	1
82	3.40000	-5.88897	-0.05000	0.80000	0.00000	120.00000	0.01000	81	82	83	1
83	3.00000	-5.19615	-0.05000	0.80000	0.00000	120.00000	0.01000	82	83	84	1
84	2.60000	-4.50333	-0.05000	0.80000	0.00000	120.00000	0.01000	83	84	85	1

85	2.20000	-3.81051	-0.05000	0.80000	0.00000	120.00000	0.01000	84	85	86	1
86	1.80000	-3.11769	-0.05000	0.80000	0.00000	120.00000	0.01000	85	86	87	1
87	1.40000	-2.42487	-0.05000	0.80000	0.00000	120.00000	0.01000	86	87	88	1
88	1.00000	-1.73205	-0.05000	0.80000	0.00000	120.00000	0.01000	87	88	89	1
89	0.60000	-1.03923	-0.05000	0.80000	0.00000	120.00000	0.01000	88	89	90	1
90	0.20000	-0.34641	-0.02500	0.80156	3.57633	120.00000	0.01000	89	90	91	1
91	0.00000	0.00000	0.75000	1.50000	90.00000	0.00000	0.01000	15	91	92	2
92	0.00000	0.00000	2.25000	1.50000	90.00000	0.00000	0.01000	91	92	93	2
93	0.00000	0.00000	3.75000	1.50000	90.00000	0.00000	0.01000	92	93	94	2
94	0.00000	0.00000	5.25000	1.50000	90.00000	0.00000	0.01000	93	94	95	2
95	0.00000	0.00000	6.75000	1.50000	90.00000	0.00000	0.01000	94	95	96	2
96	0.00000	0.00000	8.25000	1.50000	90.00000	0.00000	0.01000	95	96	97	2
97	0.00000	0.00000	9.75000	1.50000	90.00000	0.00000	0.01000	96	97	98	2
98	0.00000	0.00000	11.25000	1.50000	90.00000	0.00000	0.01000	97	98	99	2
99	0.00000	0.00000	12.75000	1.50000	90.00000	0.00000	0.01000	98	99	100	2
100	0.00000	0.00000	14.25000	1.50000	90.00000	0.00000	0.01000	99	100	0	2

N.G.F. - NUMBER OF NEW UNKNOWN IS 16

***** INPUT LINE 1 EX 0 2 1 0 1.00000E+00 0.00000E+00 0.00000E+00 0.00000E+00 0.00000E+00 0.00000E+00
 ***** INPUT LINE 2 RP 0 19 2 1001 0.00000E+00 0.00000E+00 5.00000E+00 9.00000E+01 0.00000E+00 0.00000E+00

----- FREQUENCY -----

FREQUENCY= 5.0000E+00 MHZ
 WAVELENGTH= 5.9960E+01 METERS

----- ANTENNA ENVIRONMENT -----

FINITE GROUND. SOMMERFELD SOLUTION
 RELATIVE DIELECTRIC CONST.= 10.000
 CONDUCTIVITY= 1.000E-02 MHOS/METER
 COMPLEX DIELECTRIC CONSTANT= 1.00000E+01-3.59510E+01

----- STRUCTURE IMPEDANCE LOADING -----

THIS STRUCTURE IS NOT LOADED

----- MATRIX TIMING -----

FILL= 1.090 SEC., FACTOR= 0.010 SEC.

----- ANTENNA INPUT PARAMETERS -----

TAG NO.	SEG. NO.	VOLTAGE (VOLTS)		CURRENT (AMPS)		IMPEDANCE (OHMS)		ADMITTANCE (MHOS)		POWER (WATTS)
		REAL	IMAG.	REAL	IMAG.	REAL	IMAG.	REAL	IMAG.	
2	91	1.00000E+00	0.00000E+00	1.42845E-02	-7.78775E-03	5.39656E+01	2.94214E+01	1.42845E-02	-7.78775E-03	7.14226E-03

----- CURRENTS AND LOCATION -----

LENGTHS NORMALIZED BY WAVELENGTH (OR 2.*PI/CABS(K))

SEG. NO.	TAG NO.	COORD. OF SEG. CENTER			SEG. LENGTH	CURRENT (AMPS)			PHASE
		X	Y	Z		REAL	IMAG.	MAG.	
1	1	1.1818	0.0000	-0.0051	0.08150	3.6075E-05	-1.1057E-04	1.1631E-04	-71.931
2	1	1.1003	0.0000	-0.0051	0.08150	5.0394E-05	-2.7345E-04	2.7805E-04	-79.558
3	1	1.0188	0.0000	-0.0051	0.08150	2.8494E-05	-4.0279E-04	4.0379E-04	-85.953
4	1	0.9373	0.0000	-0.0051	0.08150	-6.5475E-06	-5.1470E-04	5.1474E-04	-90.729
5	1	0.8558	0.0000	-0.0051	0.08150	-3.9156E-05	-6.2064E-04	6.2188E-04	-93.610
6	1	0.7743	0.0000	-0.0051	0.08150	-5.6329E-05	-7.3121E-04	7.3338E-04	-94.405
7	1	0.6928	0.0000	-0.0051	0.08150	-4.5536E-05	-8.5499E-04	8.5620E-04	-93.049
8	1	0.6113	0.0000	-0.0051	0.08150	6.4840E-06	-9.9671E-04	9.9674E-04	-89.627
9	1	0.5298	0.0000	-0.0051	0.08150	1.1412E-04	-1.1554E-03	1.1610E-03	-84.359

10	1	0.4483	0.0000	-0.0051	0.08150	2.9219E-04	-1.3222E-03	1.3541E-03	-77.539
11	1	0.3668	0.0000	-0.0051	0.08150	5.5375E-04	-1.4790E-03	1.5793E-03	-69.474
12	1	0.2853	0.0000	-0.0051	0.08150	9.0587E-04	-1.5969E-03	1.8360E-03	-60.436
13	1	0.2038	0.0000	-0.0051	0.08150	1.3424E-03	-1.6385E-03	2.1182E-03	-50.674
14	1	0.1223	0.0000	-0.0051	0.08150	1.8333E-03	-1.5642E-03	2.4099E-03	-40.471
15	1	0.0408	0.0000	-0.0025	0.08166	2.2800E-03	-1.3732E-03	2.6616E-03	-31.059
16	1	0.5909	1.0235	-0.0051	0.08150	3.6075E-05	-1.1057E-04	1.1631E-04	-71.931
17	1	0.5501	0.9529	-0.0051	0.08150	5.0394E-05	-2.7345E-04	2.7805E-04	-79.558
18	1	0.5094	0.8823	-0.0051	0.08150	2.8494E-05	-4.0279E-04	4.0379E-04	-85.953
19	1	0.4686	0.8117	-0.0051	0.08150	-6.5475E-06	-5.1470E-04	5.1474E-04	-90.729
20	1	0.4279	0.7411	-0.0051	0.08150	-3.9156E-05	-6.2064E-04	6.2188E-04	-93.610
21	1	0.3871	0.6705	-0.0051	0.08150	-5.6329E-05	-7.3121E-04	7.3338E-04	-94.405
22	1	0.3464	0.6000	-0.0051	0.08150	-4.5536E-05	-8.5499E-04	8.5620E-04	-93.049
23	1	0.3056	0.5294	-0.0051	0.08150	6.4839E-06	-9.9671E-04	9.9674E-04	-89.627
24	1	0.2649	0.4588	-0.0051	0.08150	1.1412E-04	-1.1554E-03	1.1610E-03	-84.359
25	1	0.2241	0.3882	-0.0051	0.08150	2.9219E-04	-1.3222E-03	1.3541E-03	-77.539
26	1	0.1834	0.3176	-0.0051	0.08150	5.5375E-04	-1.4790E-03	1.5793E-03	-69.474
27	1	0.1426	0.2470	-0.0051	0.08150	9.0587E-04	-1.5969E-03	1.8360E-03	-60.436
28	1	0.1019	0.1765	-0.0051	0.08150	1.3424E-03	-1.6385E-03	2.1182E-03	-50.674
29	1	0.0611	0.1059	-0.0051	0.08150	1.8333E-03	-1.5642E-03	2.4099E-03	-40.471
30	1	0.0204	0.0353	-0.0025	0.08166	2.2800E-03	-1.3732E-03	2.6616E-03	-31.059
31	1	-0.5909	1.0235	-0.0051	0.08150	3.6075E-05	-1.1057E-04	1.1631E-04	-71.931
32	1	-0.5501	0.9529	-0.0051	0.08150	5.0394E-05	-2.7345E-04	2.7805E-04	-79.558
33	1	-0.5094	0.8823	-0.0051	0.08150	2.8494E-05	-4.0279E-04	4.0379E-04	-85.953
34	1	-0.4686	0.8117	-0.0051	0.08150	-6.5476E-06	-5.1470E-04	5.1474E-04	-90.729
35	1	-0.4279	0.7411	-0.0051	0.08150	-3.9156E-05	-6.2064E-04	6.2188E-04	-93.610
36	1	-0.3871	0.6705	-0.0051	0.08150	-5.6329E-05	-7.3121E-04	7.3338E-04	-94.405
37	1	-0.3464	0.6000	-0.0051	0.08150	-4.5537E-05	-8.5499E-04	8.5620E-04	-93.049
38	1	-0.3056	0.5294	-0.0051	0.08150	6.4838E-06	-9.9671E-04	9.9674E-04	-89.627
39	1	-0.2649	0.4588	-0.0051	0.08150	1.1412E-04	-1.1554E-03	1.1610E-03	-84.359
40	1	-0.2241	0.3882	-0.0051	0.08150	2.9219E-04	-1.3222E-03	1.3541E-03	-77.539
41	1	-0.1834	0.3176	-0.0051	0.08150	5.5375E-04	-1.4790E-03	1.5793E-03	-69.474
42	1	-0.1426	0.2470	-0.0051	0.08150	9.0587E-04	-1.5969E-03	1.8360E-03	-60.436
43	1	-0.1019	0.1765	-0.0051	0.08150	1.3424E-03	-1.6385E-03	2.1182E-03	-50.674
44	1	-0.0611	0.1059	-0.0051	0.08150	1.8333E-03	-1.5642E-03	2.4099E-03	-40.471
45	1	-0.0204	0.0353	-0.0025	0.08166	2.2800E-03	-1.3732E-03	2.6616E-03	-31.059
46	1	-1.1818	0.0000	-0.0051	0.08150	3.6075E-05	-1.1057E-04	1.1631E-04	-71.931
47	1	-1.1003	0.0000	-0.0051	0.08150	5.0394E-05	-2.7345E-04	2.7805E-04	-79.558
48	1	-1.0188	0.0000	-0.0051	0.08150	2.8494E-05	-4.0279E-04	4.0379E-04	-85.953
49	1	-0.9373	0.0000	-0.0051	0.08150	-6.5476E-06	-5.1470E-04	5.1474E-04	-90.729
50	1	-0.8558	0.0000	-0.0051	0.08150	-3.9156E-05	-6.2064E-04	6.2188E-04	-93.610
51	1	-0.7743	0.0000	-0.0051	0.08150	-5.6329E-05	-7.3121E-04	7.3338E-04	-94.405
52	1	-0.6928	0.0000	-0.0051	0.08150	-4.5537E-05	-8.5499E-04	8.5620E-04	-93.049
53	1	-0.6113	0.0000	-0.0051	0.08150	6.4838E-06	-9.9671E-04	9.9674E-04	-89.627
54	1	-0.5298	0.0000	-0.0051	0.08150	1.1412E-04	-1.1554E-03	1.1610E-03	-84.359
55	1	-0.4483	0.0000	-0.0051	0.08150	2.9219E-04	-1.3222E-03	1.3541E-03	-77.539
56	1	-0.3668	0.0000	-0.0051	0.08150	5.5375E-04	-1.4790E-03	1.5793E-03	-69.474
57	1	-0.2853	0.0000	-0.0051	0.08150	9.0587E-04	-1.5969E-03	1.8360E-03	-60.436
58	1	-0.2038	0.0000	-0.0051	0.08150	1.3424E-03	-1.6385E-03	2.1182E-03	-50.674
59	1	-0.1223	0.0000	-0.0051	0.08150	1.8333E-03	-1.5642E-03	2.4099E-03	-40.471
60	1	-0.0408	0.0000	-0.0025	0.08166	2.2800E-03	-1.3732E-03	2.6616E-03	-31.059
61	1	-0.5909	-1.0235	-0.0051	0.08150	3.6075E-05	-1.1057E-04	1.1631E-04	-71.931
62	1	-0.5501	-0.9529	-0.0051	0.08150	5.0394E-05	-2.7345E-04	2.7805E-04	-79.558
63	1	-0.5094	-0.8823	-0.0051	0.08150	2.8494E-05	-4.0279E-04	4.0379E-04	-85.953
64	1	-0.4686	-0.8117	-0.0051	0.08150	-6.5476E-06	-5.1470E-04	5.1474E-04	-90.729
65	1	-0.4279	-0.7411	-0.0051	0.08150	-3.9157E-05	-6.2064E-04	6.2188E-04	-93.610
66	1	-0.3871	-0.6705	-0.0051	0.08150	-5.6329E-05	-7.3121E-04	7.3338E-04	-94.405
67	1	-0.3464	-0.6000	-0.0051	0.08150	-4.5537E-05	-8.5499E-04	8.5620E-04	-93.049
68	1	-0.3056	-0.5294	-0.0051	0.08150	6.4837E-06	-9.9671E-04	9.9674E-04	-89.627
69	1	-0.2649	-0.4588	-0.0051	0.08150	1.1412E-04	-1.1554E-03	1.1610E-03	-84.359
70	1	-0.2241	-0.3882	-0.0051	0.08150	2.9219E-04	-1.3222E-03	1.3541E-03	-77.539
71	1	-0.1834	-0.3176	-0.0051	0.08150	5.5375E-04	-1.4790E-03	1.5793E-03	-69.474
72	1	-0.1426	-0.2470	-0.0051	0.08150	9.0587E-04	-1.5969E-03	1.8360E-03	-60.436
73	1	-0.1019	-0.1765	-0.0051	0.08150	1.3424E-03	-1.6385E-03	2.1182E-03	-50.674
74	1	-0.0611	-0.1059	-0.0051	0.08150	1.8333E-03	-1.5642E-03	2.4099E-03	-40.471
75	1	-0.0204	-0.0353	-0.0025	0.08166	2.2800E-03	-1.3732E-03	2.6616E-03	-31.059
76	1	0.5909	-1.0235	-0.0051	0.08150	3.6075E-05	-1.1057E-04	1.1631E-04	-71.931
77	1	0.5501	-0.9529	-0.0051	0.08150	5.0394E-05	-2.7345E-04	2.7805E-04	-79.558
78	1	0.5094	-0.8823	-0.0051	0.08150	2.8494E-05	-4.0279E-04	4.0379E-04	-85.953
79	1	0.4686	-0.8117	-0.0051	0.08150	-6.5477E-06	-5.1470E-04	5.1474E-04	-90.729
80	1	0.4279	-0.7411	-0.0051	0.08150	-3.9157E-05	-6.2064E-04	6.2188E-04	-93.610
81	1	0.3871	-0.6705	-0.0051	0.08150	-5.6329E-05	-7.3121E-04	7.3338E-04	-94.405
82	1	0.3464	-0.6000	-0.0051	0.08150	-4.5537E-05	-8.5499E-04	8.5620E-04	-93.049
83	1	0.3056	-0.5294	-0.0051	0.08150	6.4837E-06	-9.9671E-04	9.9673E-04	-89.627
84	1	0.2649	-0.4588	-0.0051	0.08150	1.1412E-04	-1.1554E-03	1.1610E-03	-84.359
85	1	0.2241	-0.3882	-0.0051	0.08150	2.9219E-04	-1.3222E-03	1.3541E-03	-77.539
86	1	0.1834	-0.3176	-0.0051	0.08150	5.5375E-04	-1.4790E-03	1.5793E-03	-69.474
87	1	0.1426	-0.2470	-0.0051	0.08150	9.0587E-04	-1.5969E-03	1.8360E-03	-60.436
88	1	0.1019	-0.1765	-0.0051	0.08150	1.3424E-03	-1.6385E-03	2.1182E-03	-50.674
89	1	0.0611	-0.1059	-0.0051	0.08150	1.8333E-03	-1.5642E-03	2.4099E-03	-40.471

90	1	0.0204	-0.0353	-0.0025	0.08166	2.2800E-03	-1.3732E-03	2.6616E-03	-31.059
91	2	0.0000	0.0000	0.0125	0.02502	1.4285E-02	-7.7877E-03	1.6270E-02	-28.599
92	2	0.0000	0.0000	0.0375	0.02502	1.3937E-02	-7.9290E-03	1.6034E-02	-29.637
93	2	0.0000	0.0000	0.0625	0.02502	1.3266E-02	-7.8306E-03	1.5405E-02	-30.552
94	2	0.0000	0.0000	0.0876	0.02502	1.2291E-02	-7.4686E-03	1.4383E-02	-31.284
95	2	0.0000	0.0000	0.1126	0.02502	1.1034E-02	-6.8683E-03	1.2997E-02	-31.901
96	2	0.0000	0.0000	0.1376	0.02502	9.5187E-03	-6.0495E-03	1.1278E-02	-32.438
97	2	0.0000	0.0000	0.1626	0.02502	7.7747E-03	-5.0324E-03	9.2613E-03	-32.914
98	2	0.0000	0.0000	0.1876	0.02502	5.8311E-03	-3.8370E-03	6.9803E-03	-33.346
99	2	0.0000	0.0000	0.2126	0.02502	3.7095E-03	-2.4780E-03	4.4610E-03	-33.744
100	2	0.0000	0.0000	0.2377	0.02502	1.3643E-03	-9.2409E-04	1.6478E-03	-34.111

--- POWER BUDGET ---

INPUT POWER = 7.1423E-03 WATTS
 RADIATED POWER= 7.1423E-03 WATTS
 WIRE LOSS = 0.0000E+00 WATTS
 EFFICIENCY = 100.00 PERCENT

--- RADIATION PATTERNS ---

-- ANGLES --		- POWER GAINS -			--- POLARIZATION ---			--- E(THETA) ---		--- E(PHI) ---	
THETA	PHI	VERT.	HOR.	TOTAL	AXIAL	TILT	SENSE	MAGNITUDE	PHASE	MAGNITUDE	PHASE
DEGREES	DEGREES	DB	DB	DB	RATIO	DEG.		VOLTS	DEGREES	VOLTS	DEGREES
0.00	0.00	-162.16	-160.47	-158.23	0.66542	59.93	RIGHT	5.10064E-09	162.12	6.19731E-09	92.07
5.00	0.00	-21.08	-160.49	-21.08	0.00000	0.00	LINEAR	5.77874E-02	60.79	6.18859E-09	92.40
10.00	0.00	-15.05	-160.56	-15.05	0.00000	0.00	LINEAR	1.15672E-01	60.70	6.13637E-09	92.76
15.00	0.00	-11.52	-160.70	-11.52	0.00000	0.00	LINEAR	1.73698E-01	60.56	6.04063E-09	93.16
20.00	0.00	-9.01	-160.90	-9.01	0.00000	0.00	LINEAR	2.31807E-01	60.36	5.90152E-09	93.59
25.00	0.00	-7.08	-161.17	-7.08	0.00000	0.00	LINEAR	2.89788E-01	60.11	5.71943E-09	94.06
30.00	0.00	-5.50	-161.52	-5.50	0.00000	0.00	LINEAR	3.47227E-01	59.79	5.49496E-09	94.55
35.00	0.00	-4.20	-161.95	-4.20	0.00000	0.00	LINEAR	4.03465E-01	59.41	5.22890E-09	95.07
40.00	0.00	-3.11	-162.47	-3.11	0.00000	0.00	LINEAR	4.57551E-01	58.95	4.92228E-09	95.61
45.00	0.00	-2.20	-163.11	-2.20	0.00000	0.00	LINEAR	5.08197E-01	58.41	4.57631E-09	96.16
50.00	0.00	-1.45	-163.87	-1.45	0.00000	0.00	LINEAR	5.53723E-01	57.76	4.19239E-09	96.73
55.00	0.00	-0.87	-164.79	-0.87	0.00000	0.00	LINEAR	5.91966E-01	56.96	3.77217E-09	97.31
60.00	0.00	-0.47	-165.90	-0.47	0.00000	0.00	LINEAR	6.20123E-01	55.97	3.31748E-09	97.89
65.00	0.00	-0.27	-167.28	-0.27	0.00000	0.00	LINEAR	6.34407E-01	54.69	2.83038E-09	98.47
70.00	0.00	-0.34	-169.03	-0.34	0.00000	0.00	LINEAR	6.29303E-01	52.97	2.31320E-09	99.05
75.00	0.00	-0.81	-171.36	-0.81	0.00000	0.00	LINEAR	5.95798E-01	50.54	1.76852E-09	99.62
80.00	0.00	-2.05	-174.74	-2.05	0.00000	0.00	LINEAR	5.16751E-01	46.82	1.19923E-09	100.17
85.00	0.00	-5.35	-180.63	-5.35	0.00000	0.00	LINEAR	3.53273E-01	40.50	6.08534E-10	100.71
90.00	0.00	-999.99	-999.99	-999.99	0.00000	0.00		3.04455E-11	-152.00	3.73381E-20	103.94
0.00	90.00	-160.47	-162.16	-158.23	0.66542	-30.07	RIGHT	6.19731E-09	92.07	5.10064E-09	-17.88
5.00	90.00	-21.08	-162.13	-21.08	0.00000	0.00	LINEAR	5.77874E-02	60.79	5.11816E-09	-17.88
10.00	90.00	-15.05	-162.17	-15.05	0.00000	0.00	LINEAR	1.15672E-01	60.70	5.09951E-09	-17.84
15.00	90.00	-11.52	-162.26	-11.52	0.00000	0.00	LINEAR	1.73698E-01	60.56	5.04391E-09	-17.77
20.00	90.00	-9.01	-162.42	-9.01	0.00000	0.00	LINEAR	2.31807E-01	60.36	4.95077E-09	-17.67
25.00	90.00	-7.08	-162.66	-7.08	0.00000	0.00	LINEAR	2.89788E-01	60.11	4.81975E-09	-17.54
30.00	90.00	-5.50	-162.97	-5.50	0.00000	0.00	LINEAR	3.47227E-01	59.79	4.65073E-09	-17.37
35.00	90.00	-4.20	-163.36	-4.20	0.00000	0.00	LINEAR	4.03465E-01	59.41	4.44385E-09	-17.17
40.00	90.00	-3.11	-163.85	-3.11	0.00000	0.00	LINEAR	4.57551E-01	58.95	4.19953E-09	-16.94
45.00	90.00	-2.20	-164.45	-2.20	0.00000	0.00	LINEAR	5.08197E-01	58.41	3.91845E-09	-16.67
50.00	90.00	-1.45	-165.19	-1.45	0.00000	0.00	LINEAR	5.53722E-01	57.76	3.60159E-09	-16.37
55.00	90.00	-0.87	-166.08	-0.87	0.00000	0.00	LINEAR	5.91965E-01	56.96	3.25023E-09	-16.04
60.00	90.00	-0.47	-167.17	-0.47	0.00000	0.00	LINEAR	6.20122E-01	55.97	2.86596E-09	-15.68
65.00	90.00	-0.27	-168.53	-0.27	0.00000	0.00	LINEAR	6.34405E-01	54.69	2.45067E-09	-15.28
70.00	90.00	-0.34	-170.27	-0.34	0.00000	0.00	LINEAR	6.29302E-01	52.97	2.00662E-09	-14.87
75.00	90.00	-0.81	-172.59	-0.81	0.00000	0.00	LINEAR	5.95796E-01	50.54	1.53638E-09	-14.42
80.00	90.00	-2.05	-175.95	-2.05	0.00000	0.00	LINEAR	5.16750E-01	46.82	1.04291E-09	-13.96
85.00	90.00	-5.35	-181.84	-5.35	0.00000	0.00	LINEAR	3.53272E-01	40.50	5.29551E-10	-13.47
90.00	90.00	-999.99	-999.99	-999.99	0.00000	0.00		3.04454E-11	-152.00	3.25109E-20	-10.27

AVERAGE POWER GAIN= 5.82049E-01 SOLID ANGLE USED IN AVERAGING=(0.5000)*PI STERADIANS.

POWER RADIATED ASSUMING RADIATION INTO 4*PI STERADIANS = 4.15715E-03 WATTS

***** INPUT LINE 3 EN 0 0 0 0 0.00000E+00 0.00000E+00 0.00000E+00 0.00000E+00 0.00000E+00 0.00000E+00

RUN TIME = 2.440

5. Error Messages

Error statements and warnings of unusual conditions are listed below, with the names of the routines from which the messages originate. Most error messages start with the name or the routine printing the message. The symbol --- indicates a number that will be printed.

1. ARC: ERROR - ARC ANGLE EXCEEDS 360. DEGREES

Routine: ARC

Error on the GA command; the arc angle specified cannot be greater than 360 degrees.

2. CATNRY: ERROR - INCORRECT PARAMETERS RECEIVED

Routine: CATNRY

A catenary wire has been specified between two points that are vertically aligned. There must be a horizontal displacement between the end points.

3. CATSOL: SOLUTION DID NOT CONVERGE

Routine: CATSOL

The iterative solution for the parameters of a catenary did not converge. A possible cause is abnormal parameters on the CW command.

4. CONECT: ERROR - NO. NGF PATCHES CONNECTED TO NEW SEGMENTS EXCEEDS LIMIT OF ---

Routine: CONECT

Array dimension set by the parameter NSPNGF must be increased.

5. CONECT: ERROR - NO. NGF SEGMENTS CONNECTED TO NEW SEGMENTS EXCEEDS LIMIT OF ---

Routine: CONECT

Array dimension set by the parameter NSCNGF must be increased.

6. CONECT: ERROR - SEGMENT --- EXTENDS BELOW GROUND

Routine: CONECT

When the first parameter on the GE command is +1, segments cannot extend below the ground plane (negative z .)

7. CONECT: ERROR - SEGMENT --- LIES IN GROUND PLANE

Routine: CONECT

When the first parameter on the GE command is +1 or -1, segments cannot lie in the ground plane ($z = 0$.)

8. CONECT: SEGMENT CONNECTION ERROR FOR SEGMENT ---
Routine: CONECT
 Possible causes: the number of segments at a junction exceeds the limit set by parameter NSJMAX; some segment lengths are zero; array overflow.
9. COUPLE: ERROR - COUPLING= --- ; MUST BE BETWEEN 0 AND 1. SEGMENTS: TAG1, TSEG1, SEG1, TAG2, TSEG2, SEG2
Routine: COUPLE
 An impossible value has been obtained for coupling between the points TAG1, TSEG1 (absolute segment number SEG1) and TAG2, TSEG2 (absolute segment number SEG2.) Possible causes are an inaccurate solution, or one of the segments specified is in a bad location such as a wire end.
10. DATAGN: ERROR - GF MUST BE FIRST COMMAND IN GEOMETRY DATA SECTION
Routine: DATAGN
 The GF command must come before any other commands in the data set except CM or CE.
11. DATAGN: NUMBER OF WIRE SEGMENTS AND SURFACE PATCHES EXCEEDS DIMENSION LIMIT.
Routine: DATAGN
 The number of segments and patches exceeds the limit set by parameter MAXSEG.
12. DATAGN: PATCH DATA ERROR
Routine: DATAGN
 Invalid data was read from the SP, SM or SC commands; or a required SC command was not found.
13. DATAGN: SEGMENT DATA ERROR
Routine: DATAGN
 A segment with zero length or zero radius was found.
14. DATAGN: STRUCTURE GEOMETRY DATA ERROR
Routine: DATAGN
 The mnemonic read from a command in the structure geometry section (before GE) does not match a valid command name.
15. EFLD: ERROR - MUST USE SOMMERFELD FOR INTERACTION ACROSS THE INTERFACE
 $[X_j, Y_j, Z_j, X_i, Y_i, Z_i]$
Routine: EFLD
 Segments or patches on opposite sides of the interface were found during evaluation of interactions. The Sommerfeld solution (GN 2,...) must be used for interaction across the interface. The coordinates of the source segment were (X_j, Y_j, Z_j) and the evaluation point was (X_i, Y_i, Z_i) .

16. ERROR: ERROR IN FILE OPERATION -

[Message about file error]

Routine: ERROR

An error occurred when attempting to open the input or output file or in reading or writing a direct-access file for the matrix solution. A description of the error from the computer system will be printed (VAX only). This message is displayed on the user's terminal screen.

17. EVLUB: ERROR - RHO, ZZ, ZP, IQAX = --- --- --- ---

Routine: EVLUB

Subroutine EVLUB can only be called with the source height $ZP \leq 0$ and the evaluation point height $ZZ \geq 0$. Otherwise this message is printed and the program stops. This indicates a program malfunction.

18. FACTR: PIVOT(---)= ---

Routine: FACTR

The program was forced to use a small pivot element in factoring the matrix into LU parts. The matrix may be nearly singular. Possible causes are overlapping segments or patches, zero-length segments or patches, or an array overflow.

19. FBLOCK: ERROR - INSUFFICIENT STORAGE FOR MATRIX --- ---

Routine: FBLOCK

The array storage allocated for the matrix (parameter MAXMAT) must be large enough for two columns of the matrix or, in the case of symmetry, two columns of a submatrix. The parameter MAXMAT must be increased and the code recompiled.

20. FBLOCK: ERROR - NUMBER OF SYMMETRIC SECTIONS EXCEEDS LIMIT: MAXSYM = ---
NEEDED: ---

Routine: FBLOCK

The number of symmetric sections in a structure exceeds the limit set by the parameter MAXSYM. The value of MAXSYM must be increased and the code recompiled.

21. FBLOCK: SYMMETRY ERROR - NROW,NCOL= --- ---

Routine: FBLOCK

Inconsistent values - NROW times the number of symmetric section must be equal to NCOL. Possible causes are an array overflow or other program malfunction.

22. FBNGF: ERROR - INSUFFICIENT STORAGE FOR INTERACTION MATRICES; IRESRV, IMAT,
NEQ, NEQ2 = --- --- --- ---

Routine: FBNGF

Array storage was exceeded in a NGF solution. The value of the parameter MAXMAT must be increased and the code recompiled.

23. GETIOF: ERROR - UNABLE TO OPEN FILE [*File Name*]
Routine: GETIOF
 If the program is unable to open the requested input or output file, a message from subroutine ERROR is displayed on the terminal or written in the batch log file. After a number of retries set by the variable MAXERR in subroutine GETIOF (currently 20), this message is displayed and the program terminates.
24. GNDINO: EPSC FROM FILE= --- SHOULD BE ---
Routine: GNDINO
 A file for the Sommerfeld-integral tables with the appropriate ϵ_r , σ and frequency was not found. This message is only for information. The program will continue to run and will compute the necessary tables.
25. GNDINO: ERROR READING SOMNTX FILE [*File Name*]
Routine: GNDINO
 The program was unable to read the Sommerfeld integral tables from the specified file as part of a NGF solution.
26. GNDINO: UNABLE TO OPEN FILE [*File Name*]
Routine: GNDINO
 The file spicified for the Sommerfeld integral tables was not found or could not be opened. The program will continue to run and will compute the necessary tables and write the file.
27. HANK12: ERROR - CANNOT EVALUATE H(Z) FOR Z=0.
Routine: HANK12
 An attempt was made to evaluate the Hankel function for an argument of zero.
28. HANK2Z: ERROR - CANNOT EVALUATE H(Z) FOR Z=0.
Routine: HANK2Z
 An attempt was made to evaluate the Hankel function for an argument of zero.
29. INSET: ERROR - SHEATH MAY NOT BE ADDED TO WIRE IN NGF SECTION
Routine: INSET
 An IS command specifies segments in the NGF that cannot be modified. The program stops.
30. INSET: ERROR - SHEATH RADIUS .LE. SEGMENT RADIUS FOR SEGMENT ---
Routine: INSET
 An IS command specifies a sheath radius less than the segment radius. The program stops.
31. INSET: ERROR - NO SEGMENTS MATCHED THE RANGE ON THE PREVIOUS IS COMMAND
Routine: INSET
 An error was made in specifying segments on an IS command. The program stops.

32. INSET: WARNING - OVERLAPPING SHEATH SPECIFICATIONS. LAST ONE WAS USED.

Routine: INSET

Two IS commands specified segment ranges that overlap. Only one sheath can be applied on a given segment, so that specified on the second of the two IS commands is used.

33. INTRPD: ERROR - POINT OUT OF GRID; RHO, ZZ, AZP= --- --- ---

Routine: INTRPD

This message indicates a program malfunction involving the Sommerfeld ground solution.

34. ISEGNO: ERROR - NO SEGMENT HAS A TAG-SEGMENT REFERENCE OF --- ---

Routine: ISEGNO

This error results from an input data error and may occur at any point where a tag number is used to identify a segment. Execution is terminated. Data on the GM, CP, NT, TL and EX commands should be checked.

35. ISEGNO: ERROR - PARAMETER SPECIFYING SEGMENT POSITION IN A GROUP OF EQUAL TAGS MUST NOT BE ZERO

Routine: ISEGNO

This error results from an input data error and may occur at any point where a tag number is used to identify a segment. Execution is terminated. Data on the GM, CP, NT, TL and EX commands should be checked.

36. JNFIND: ERROR AT --- END OF SEGMENT ---
MULTIPLE WIRE JUNCTION AT CONNECTION TO SURFACE PATCH IS NOT ALLOWED

Routine: JNFIND

Only a single segment can connect to a given surface patch. The segment number and the end (1 or 2) of the segment that caused the error are printed.

37. JNFIND: ERROR AT --- END OF SEGMENT ---
NUMBER OF CONNECTED SEGMENTS EXCEEDS LIMIT OF ---

Routine: JNFIND

The number of segments connected at a junction exceeds the limit set by the parameter NSJMAX.

38. LFACTR: PIVOT(---)= ---

Routine: LFACTR

The program was forced to use a small pivot element in factoring the matrix into LU parts. The matrix may be nearly singular. Possible causes are overlapping segments or patches, zero length segments or patches, or an array overflow.

39. LOAD: ERROR IN SPECIFYING LOADED SEGMENTS

Routine: LOAD

Second segment specified is less than the first segment, or the second segment is greater than the total number of segments.

40. LOAD: ERROR - LOADING MAY NOT BE ADDED TO SEGMENTS IN N.G.F. SECTION

Routine: LOAD

Loading on segments in a NGF file must be specified with LD commands before the NGF file is written. Otherwise, loading can be introduced on segments in an existing NGF file by using the NT command.

41. LOAD: IMPROPER LOAD TYPE CHOSEN, REQUESTED TYPE IS ---

Routine: LOAD

The first parameter on a LD command does not correspond to a valid load type (values 0 through 5.)

42. LOAD: LD COMMAND ERROR, NO SEGMENT HAS A TAG NO. = ---

Routine: LOAD

The tag number used on a LD command does not match the tag of any existing segment.

43. LOAD: SOME OF THE ABOVE SEGMENTS HAVE BEEN LOADED TWICE - IMPEDANCES ADDED

Routine: LOAD

This is only a warning message. The solution will continue with the overlapping impedances added.

44. MAIN: ERROR - N.G.F. IN USE. CANNOT WRITE NEW N.G.F.

Routine: MAIN

When a N.G.F. file has been read (GF command) the WG command cannot be used to write a new N.G.F. file.

45. MAIN: FAULTY INPUT COMMAND LABEL AFTER GEOMETRY SECTION

Routine: MAIN

A command with an unrecognizable mnemonic has been encountered in the program control section, following the structure-geometry commands. Execution terminated.

46. MOVE: ERROR - SEGMENTS FROM AN NGF FILE CANNOT BE MOVED

Routine: MOVE

A GM command cannot operate on segments in the NGF file. If the starting segment in the range specified on the GM command is in the NGF section it is changed to the next segment above the NGF section. If the final segment in the range is in the NGF section, the code stops with this error message.

47. NETSOL: ERROR - NETWORK ARRAY DIMENSIONS TOO SMALL

Routine: NETSOL

The number of NT and TL commands used exceeds the array limit set by the parameter NETMX. The value of NETMX must be increased and the code recompiled.

48. PARSIT: INPUT ERROR - INVALID NUMBER AT INTEGER POSITION ---

***** TEXT --> [*Input Record*]

Routine: PARSIT

Invalid numerical data was found at the position indicated. The record containing the error is printed.

49. PARSIT: INPUT ERROR - INVALID NUMBER AT REAL POSITION ---

***** TEXT --> [*Input Record*]

Routine: PARSIT

Invalid numerical data was found at the position indicated. The record containing the error is printed.

50. PARSIT: INPUT ERROR - TOO MANY FIELDS IN RECORD

***** TEXT --> [*Input Record*]

Routine: PARSIT

The total number of integer and real numbers in an input record exceeds the maximum allowed.

51. PARSIT: INVALID ENTRY OF NON-NUMERIC DATA

***** TEXT --> [*Input Record*]

Routine: PARSIT

Text used to specify a file name must follow all numeric data in the record. Text used for annotation must follow the numeric data and any file name, and be separated from the data by an exclamation mark (!).

52. PATCH: ERROR - CORNERS OF QUADRILATERAL PATCH DO NOT LIE IN A PLANE

Routine: PATCH

The four corners of a quadrilateral patch must lie in a plane. An easy way to avoid this error is to define the patch in one of the coordinate planes and then move it to the desired location with a GM command.

53. PTRECN: RECEIVING PATTERN STORAGE TOO SMALL; ARRAY TRUNCATED

Routine: PTRECN

The number of angles requested in a receiving pattern exceeds the limit set by the parameter MAXRCP. Execution will continue, but storage of normalized pattern values will be truncated.

54. RDLSOL: ERROR - ILLEGAL FINAL SEGMENT LENGTH

Routine: RDLSOL

The final segment length specified for a tapered wire (GW and GC commands) must be greater than zero and less than the total distance between the end points.

55. RDLSOL: ERROR - ILLEGAL STARTING SEGMENT LENGTH

Routine: RDLSOL

The initial segment length specified for a tapered wire (GW and GC commands) must be greater than zero and less than the total distance between the end points.

56. RDLSOL: SOLUTION DID NOT CONVERGE

Routine: RDLSOL

The iterative solution for a tapered wire did not converge. A possible cause is invalid data on a GC command when the first segment length is specified.

57. RDPAT: WARNING - THE CLIFF OR RADIAL-WIRE GROUND SCREEN APPROXIMATIONS ARE NOT INCLUDED IN CALCULATING GROUND WAVE (RP1,...)

Routine: RDPAT

The cliff or radial-wire ground screen approximations use modified reflection coefficients and are only effective in computing the radiated field (RP0, ...). The code will continue to run, but the result for ground wave will be computed for a flat ground with the primary ground parameters.

58. RECIN: ERROR READING FILE --- PROGRAM RECORD NO. --- I1, I2 = --- ---

TRACE - [message]

Routine: RECIN

An error occurred when reading a direct-access file for the matrix solution. The logical unit number of the file is given. The logical record number is the number of the record in the direct-access file. This may be greater than the program record number when the operating system limits the length of the logical records. The data is being read into locations I1 to I2 in an array in memory. The message will give the name of the subroutine calling RECIN and the location of the call.

59. RECOT: ERROR WRITING FILE --- PROGRAM RECORD NO. --- LOGICAL RECORD NO. --- I1, I2= --- ---

TRACE - [message]

Routine: RECOT

An error occurred when writing a direct-access file for the matrix solution. The logical unit number of the file is given. The logical record number is the number of the record in the direct-access file. This may be greater than the program record number when the operating system limits the length of the logical records. The data is being written from locations I1 to I2 in an array in memory. The message will give the name of the subroutine calling RECOT and the location of the call.

60. REFLEC: GEOMETRY DATA ERROR - PATCH --- LIES IN PLANE OF SYMMETRY
Routine: REFLEC
 A patch may not lie in or cross a plane of symmetry about which the structure is reflected, since the patch and its image will coincide or cross. Execution is terminated.
61. REFLEC: GEOMETRY DATA ERROR - SEGMENT --- LIES IN PLANE OF SYMMETRY
Routine: REFLEC
 A segment may not lie in or cross a plane of symmetry about which the structure is reflected, since the segment and its image will coincide or cross. Execution is terminated.
62. RMSRS: ERROR IN L. S. SOLUTION FOR COMPONENT ---
Routine: RMSRS
 The least-squares solution for modeling Sommerfeld integral values encountered a singular matrix. This indicates a malfunction, possibly due to the failure of the table parameters to be set by DATA statements. The program stops.
63. ROM1: STEP SIZE LIMITED AT LAMBDA = --- ---
Routine: ROMBG
 The adaptive Romberg integration algorithm for evaluating Sommerfeld integrals was limited by the minimum allowed step size (1/NM). The solution will continue. Accuracy may be lost, but often the problem is not serious. One of the integrands may have a discontinuity at the point LAMBDA in the complex λ plane.
64. ROMBG: ERROR - B LESS THAN A
Routine: ROMBG
 A program malfunction occurred in numerical integration.
65. ROMBG: STEP SIZE LIMITED AT Z = ---
Routine: ROMBG
 The adaptive Romberg integration algorithm was limited by the minimum allowed step size (1/NM). The solution will continue. Accuracy may be lost, but often the problem is not serious. This message may result from a wire very close to a ground plane or errors in the table-lookup algorithm for Sommerfeld integral values.
66. RSETEX: ERROR IN EX COMMAND - EXCITATION TYPE --- IS INVALID
Routine: RSETEX
 The first parameter on an EX command does not match any valid excitation type.
67. RSETEX: NUMBER OF EXCITATION COMMANDS EXCEEDS STORAGE ALLOTTED
Routine: RSETEX
 The number of EX commands in a group exceeds the limit set by the parameter NSOMAX.

68. RSETFR: ERROR - FR COMMAND IS NOT ALLOWED WITH N.G.F.
Routine: RSETFR
A FR command cannot be used when a N.G.F. file has been read. The frequency set when the N.G.F. file was written must be used.
69. RSETGN: ERROR - GN COMMAND IS NOT ALLOWED WITH N.G.F.
Routine: RSETGN
A GN command cannot be used after a NGF file has been read. The ground parameters must be set before the NGF file is written.
70. RSETGN: RADIAL WIRE G. S. APPROXIMATION MAY NOT BE USED WITH SOMMERFELD GROUND OPTION
Routine: RSETGN
The radial-wire ground screen approximation can only be used with the reflection-coefficient approximation for ground (GN 0, ...).
71. RSETIS: DATA FAULT ON IS COMMAND NO. --- ITAG STEP1= --- IS GREATER THAN ITAG STEP2= ---
Routine: RSETIS
The number of the second segment specified on the IS command must be greater than the number of the first segment. Execution is terminated.
72. RSETIS: NUMBER OF IS COMMANDS EXCEEDS STORAGE ALLOTTED
Routine: RSETIS
The number of IS commands exceeds the dimension limit set by the parameter MAXIS. Execution is terminated.
73. RSETLD: DATA FAULT ON LD COMMAND NO. --- ITAG STEP1= --- IS GREATER THAN ITAG STEP2= ---
Routine: RSETLD
When several segments are loaded, the number of the second segment specified must be greater than the number of the first segment. Execution is terminated.
74. RSETLD: NUMBER OF LD COMMANDS EXCEEDS STORAGE ALLOTTED
Routine: RSETLD
The number of LD commands in a group exceeds the limit set by the parameter LOADMX.
75. RSETNT: NUMBER OF NETWORK COMMANDS EXCEEDS STORAGE ALLOTTED
Routine: RSETNT
The number of NT commands in a group exceeds the limit set by the parameter NETMX.

76. RSETUM: ERROR - UM COMMAND IS NOT ALLOWED WITH N.G.F.
Routine: RSETUM
 A UM command cannot be used when a N.G.F. file has been read. The medium parameters should be specified when the N.G.F. file is written.
77. SADPT: ERROR - RHO, ZZ, ZP= --- --- ---
Routine: SADPT
 Coordinates given to determine the saddle point in a ground solution were out of range. The source position ZP must be ≤ 0 , and the evaluation point height ZZ must be ≥ 0 .
78. SEGCHK: ERROR - SEGMENTS --- AND --- ARE PARALLEL AND OVERLAPPING
Routine: SEGCHK
 The segments lie on top of each other over part of their lengths. By default the program will stop. Another option can be requested on the GE command, but usually the error in the data should be found and corrected.
79. SEGCHK: ERROR - SEGMENTS --- AND --- INTERSECT AT A MIDPOINT
Routine: SEGCHK
 Segments should only touch each other at their ends. If they cross at a midpoint or in a "T" junction this message will be printed. By default the program will stop. Another option can be requested on the GE command, but usually the error in the data should be found and corrected.
80. SEGCHK: WARNING - SEGMENTS --- AND --- ARE PARALLEL AND SEPARATED BY LESS THAN THE SUM OF THEIR RADII
Routine: SEGCHK
 This condition probably violates the thin-wire approximation. By default the program will continue to run, but the I2 parameter on the GE command can be set to cause execution to stop after this message.
81. SEGCHK: WARNING - SEGMENTS --- AND --- CROSS AT A MIDPOINT WITH SEPARATION LESS THAN THE SUM OF THEIR RADII
Routine: SEGCHK
 This condition probably violates the thin-wire approximation. By default the program will continue to run, but the I2 parameter on the GE command can be set to cause execution to stop after this message.
82. SEGCHK: WARNING - THE CENTER OF SEGMENT --- IS WITHIN THE VOLUME OF SEGMENT ---
Routine: SEGCHK
 This condition probably violates the thin-wire approximation. By default the program will continue to run, but the I2 parameter on the GE command can be set to cause execution to stop after this message.

83. SOMTRP: ERROR - ARRAY OVERFLOW - NPTS= ---

Routine: SOMTRP

The total number of points in the interpolation tables for Sommerfeld integrals exceeds the dimension limit. The program stops.

84. STRAC: AN ERROR OCCURRED IN FILLING THE INTERPOLATION TABLES, IR, IZ= ---

Routine: STRAC

An unrecoverable error occurred in filling the interpolation table for locating saddle points for interaction across the ground surface. The error was detected in subroutine SDLPT. The problem may result from ground parameters out of the normal range.

85. WHEN MULTIPLE FREQUENCIES ARE REQUESTED, ONLY ONE NEAR FIELD REQUEST CAN BE USED - LAST REQUEST READ IS USED

Routine: RSETNF

Only one NE or NH command, plus the RP command, can be included in a frequency loop.

86. ZPSAVE: STORAGE FOR IMPEDANCE NORMALIZATION TOO SMALL; ARRAY TRUNCATED

Routine: ZPSAVE

The number of frequencies requested on the FR command exceeds the array dimension for impedance normalization (parameter NSZMAX.) Execution continues, but impedances for frequencies beyond the limit will not be normalized.

6. Array Dimension Limitations

Array dimensions in NEC-4 place some limits on the model size and the number of some input commands. The important dimensions are set by named parameters to make them easy to change. The parameter values are set in a file NECPAR.INC that is brought into the NEC-4 source code at compile time by use of INCLUDE statements. If it is necessary to increase some of these limits the file NECPAR.INC must be edited and the NEC-4 code recompiled. The only dimensions that require a significant amount of computer memory are MAXSEG, with a memory requirement of $30(\text{MAXSEG})$ real numbers, and MAXMAT, with a requirement of $2(\text{MAXMAT})^2$ real numbers. The functions of the parameters are defined below:

- MAXSEG** – Maximum number of segments and patches. Any combinations of segments and patches can be included in a model as long as their sum is less than or equal to MAXSEG
- MAXMAT** – The array reserved in memory for storing the moment-method interaction matrix is large enough to store $\text{MAXMAT} \times \text{MAXMAT}$ complex numbers. Thus for a model with N wire segments and M patches and no symmetry, the requirement is $\text{MAXMAT} \geq N + 2M$ for the solution to be done in memory. If $N + 2M > \text{MAXMAT}$ the code will use disk storage for the matrix. The solution time will then be increased by the time for file I/O. When the solution can take advantage of model symmetry, the limit for storing the matrix in memory is $(\text{MAXMAT})^2 \geq (N + 2M)/N_p$ where N_p is the number of symmetric sections. When disk storage is used, $(\text{MAXMAT})^2$ must be at least $2(N + 2M)$. The parameter IRESRV in NEC-3 was equivalent to $(\text{MAXMAT})^2$.
- MAXSYM** – Maximum number of symmetric sections when symmetry is used in the solution.
- LOADMX** – Maximum number of LD commands.
- NETMX** – Maximum number of NT and TL commands, combined. NETMX is also the maximum number of distinct segments that can have network or transmission line connections.
- NSOMAX** – Maximum number of EX commands.
- MAXIS** – Maximum number of IS commands.
- NSJMAX** – Maximum number of connected segments. If N^- and N^+ are the numbers of segments connected to ends 1 and 2 of a segment, then NSJMAX must be at least $N^- + N^+ + 1$.
- NSCNGF** – Maximum number of segments in a NGF file that connect to new segments in a Numerical Green's function solution.
- NSPNGF** – Maximum number of surface patches in a NGF file that connect to new segments in a Numerical Green's function solution.

7. Differences between NEC-4 and NEC-3

NEC-4 differs from the earlier code NEC-3 in a number of ways, including new solution algorithms to improve accuracy and numerical precision, updated code structure, new input commands and some modifications to the output. The solution algorithms for wires in NEC-4 have been changed significantly from those in NEC-3. To correct the loss of precision that occurred in modeling electrically small wire segments, the current expansion function

$$I_j(s) = A_j + B_j \sin k_s(s - s_j) + C_j \cos k_s(s - s_j)$$

used in NEC-3 has been changed to

$$I_j(s) = A'_j + B_j \sin k_s(s - s_j) + C_j[\cos k_s(s - s_j) - 1]$$

in NEC-4. While the new form is equivalent to the old one, it avoids the loss of precision that occurred for electrically short segments when the cosine and constant terms became nearly the same. A number of other changes have been made in the evaluation of currents and fields to avoid loss of precision or underflow or overflow at low frequencies.

A serious problem with NEC-3 was inaccurate solutions for stepped-radius wires or junctions of tightly coupled wires. A number of changes have been made to correct these problems. The thin-wire approximation is now implemented with the current treated as a filament on the wire surface and the boundary condition enforced on the wire axis. With the opposite convention used in NEC-3, the solution tended to converge to a continuous charge distribution at a step in radius, rather than the correct discontinuity in charge based on wire radius. Also, in forming the current basis functions, the charge distribution at a junction is now obtained by solving a small moment-method problem, taking account of the actual positions and radii of the segments. This treatment replaces the simple function of the logarithm of wire radius that was used in NEC-3, and takes into account the proximity of wires at a junction and some of the edge effect seen in the charge at a step in radius.

With the boundary condition enforced on the wire axis, the openings at wire ends should be closed with end caps. This is particularly important when the ratio of segment length to radius is on the order of two or less. Wire ends are closed with flat end caps in NEC-4 with the current and charge density assumed continuous from the wire onto the cap. Also, end caps may optionally be included on voltage sources and segments with impedance loads to reduce the excitation of the inside of the wire. This approximate treatment was found to be about as effective as the extended thin-wire kernel included as an option in NEC-3. The extended thin-wire kernel option (**EK** command) has been dropped from NEC-4.

As a result of these changes, NEC-4 will give slightly different results than NEC-3. The differences should be within the convergence limits of the solution, except when NEC-3 is wrong, as for VLF problems, changes in wire radius or tightly coupled junctions. Other features of NEC-4 that differ from NEC-3 follow:

- The solution for large matrices stored on disk now uses direct-access file I/O, so that only a single copy of the matrix must be maintained on the disk. NEC-3, using sequential-access files, needed four copies of the matrix — input, output and two scratch files for Gaussian elimination.
- Much of the NEC-4 code has been rewritten to break large routines into smaller modules and to use more Fortran 77 constructs.
- Important array dimensions, such as the maximum number of segments, matrix size and number of segments at a junction are now set in PARAMETER statements to make the limits easy to change.
- The input commands are read by a routine that accepts numbers separated by spaces or commas. Text can be added after the data, with an exclamation-mark separator, to document the input lines.
- Commands that require the code to read or write a file (**GN**, **GF** and **WG**) can now include a name for the file. The file name is typed after the data, separated by spaces or a comma. If no file name is entered, the default name of SOMS.NEC is used for the Sommerfeld-ground file, and NGFS.NEC for the Numerical Green's Function in the single-precision code.
- If a file with the required data is not found for a Sommerfeld-ground solution NEC-4 will generate the data. This will require a moderate amount of time, similar to running SOMNTX.
- The **CM** or **CE** commands can now be used anywhere in the input data to insert documentation into the output.
- Wires with an insulating sheath can be modeled in NEC-4 by using the **IS** command.
- The option to determine the impedance of a lossy round wire (**LD 5,...**) now accepts the relative permeability of the wire as well as bulk conductivity.
- The table of charge densities obtained with the **PQ** command now shows the charge at free wire ends as well as at segment centers.
- A group of **EX** commands can contain a mixture of incident plane wave and voltage source specifications. Incrementing over incidence angles of a plane wave works only on the last plane-wave definition entered in a group.
- The field strength for an incident plane wave can be set on the **EX** command. The default is 1 volt/m.
- The option on the **EX** command to compute relative matrix asymmetry is no longer

available. Reciprocity can be tested by computing transmitting and receiving patterns or bistatic scattering.

- The **CP** command, to compute maximum coupling, now accepts only two segments in the form TAG1, SEG1, TAG2, SEG2. The coupling calculation is done immediately after the **CP** command, rather than waiting for the segments to be excited with **EX** commands, as in NEC-3. The coupling calculation should now be done correctly when the model uses transmission lines or networks (**TL** and **NT**.) NEC-3 did not calculate coupling correctly when networks or transmission lines were present.
- The first integer parameter on the **GD** command now selects the type of cliff: 1 for linear or 2 for circular. A cliff specified on the **GN** command can only be linear. When the cliff is specified it will be included in the radiated field calculation; it is no longer necessary to set a flag in the **RP** command.
- The cliff and radial-wire ground screen approximations, based on plane-wave reflection coefficients, now are used in computing fields due to patches as well as wires.
- The **CW** command can be used to generate a wire with the catenary shape of a hanging cable.
- The **GH** command has been changed to generate either a helix or a log or Archimedes spiral.
- The **GC** command, used with **GW** to define a tapered wire, now accepts either the ratio of successive segment lengths or the length of the first segment.
- The operation of the **GM** command in moving or duplicating segments can now be limited to a range between a starting segment and ending segment. In NEC-3, the range could only be from a starting segment through the last existing segment.
- The code will test for illegal intersections of segments or violations of the thin-wire approximation. This test is controlled with the **GE** command.
- The **EK** and **KH** commands from NEC-3 may be included in the NEC-4 input, but they have no effect on the solution.

Differences between NEC-4.1 and NEC-4:

- The **LE** and **LH** commands were added to compute near E and H fields along a line and to evaluate the line integral.
- The moment-method solution for charge at a junction was modified to avoid stability problems that occurred in the old treatment at junctions of many wire with differing lengths.

- The **JN** command was added to switch from the MM solution for charge at a junction to the form used in NEC-2 and 3.
- The field evaluation for voltage-source end caps was made more accurate.

References

- [1] J. Strauch and S. Thompson, *Interactive Graphics Utility for Army NEC Automation (IGUANA)*, Naval Ocean Systems Center, Rept. CR 308, 1985.
- [2] R. J. Marhefka and J. W. Silvestro, *Near Zone - Basic Scattering Code User's Manual with Space Station Applications*, Technical Rept. 716199-13, The Ohio State University ElectroScience Laboratory, March 1989.
- [3] R. R. McLeod, *Temporal Scattering And Response Software, Users' Manual, Version 2.1 (R)*, UCRL-MA-104861, Lawrence Livermore National Laboratory, CA, September 1990.
- [4] G. J. Burke, *NEC-4 Theory Manual*, Lawrence Livermore National Lab., Rept. UCRL-MA-109338, January 1992.
- [5] G. J. Burke, *Numerical Electromagnetics Code (NEC) - Method of Moments; Part I: Program Description - Theory, Part II: Program Description - Code, Part III: User's Guide*, Lawrence Livermore National Lab., Rept. UCID-18834, January 1981.
- [6] G. J. Burke, *Treatment of Small Wire Loops in the Method of Moments Code NEC*, Lawrence Livermore National Laboratory, Rept. UCID-21196, October 1987.
- [7] J. H. Richmond, "A Wire-Grid Model for Scattering by Conducting Bodies," *IEEE Trans. Antennas and Propagation*, Vol. AP-14, p. 782, 1966.
- [8] K. S. H. Lee, L. Marin and J. P. Castillo, "Limitations of Wire-Grid Modeling of a Closed Surface," *IEEE Trans. Electromagnetic Compatibility*, Vol. EMC-18, No. 3, pp. 123-129, August 1976.
- [9] A. C. Ludwig, "Wire Grid Modeling of Surfaces," *IEEE Trans. Antennas and Propagation*, Vol. AP-35, No. 9, pp. 1045-1048, 1987.
- [10] J. Moore and R. Pizer, *Moment Methods in Electromagnetics: Techniques and Applications*, Wiley, New York, 1984.
- [11] D. L. Sengupta, Chapter 10 in *Electromagnetic and Acoustic Scattering by Simple Shapes*, J. J. Bowman, T. B. A. Senior and P. L. E. Uslenghi, Editors, North-Holland Publishing Co., Amsterdam, 1969.
- [12] G. J. Burke and E. K. Miller, "Modeling Antennas Near to and Penetrating a Lossy Interface," *IEEE Trans. Antennas and Propagation*, Vol. AP-32, No. 10, pp. 1040-1049, 1984.

- [13] G. J. Burke, "Modeling Monopoles on Radial-Wire Ground Screens," *Applied Computational Electromagnetics Newsletter*, Vol. 1, No. 1, February 1986.
- [14] R. W. P. King and G. S. Smith, *Antennas in Matter*, MIT Press, Cambridge, Massachusetts, 1981.
- [15] G. J. Burke, *A Model for Insulated Wires in the Method of Moments Code NEC*, Lawrence Livermore National Laboratory, Rept. UCID-21301, January, 1988.