

The Nuts and Bolts of Tuning Varactors

Introduction

Many electronic systems must be tuned through the variation of reactance of one or more circuit elements. In these applications it is often desirable to perform this tuning under electronic rather than manual control. Tuning varactor diodes, which are pn junction devices that act as voltage-controlled variable capacitors, can perform this function.

This paper describes the construction of tuning varactor diodes, the effects of construction on varactor diode performance, the types of silicon (Si) varactor diodes available and modeling of varactor diodes.

pn Junction

The pn diode has been described extensively in the literature^{i,ii}. As shown in Figure 1, a practical tuning varactor pn junction diode consists of two layers, the P and the N layers, which are formed on top of a low-resistance substrate layer, typically known as the N⁺ layer.

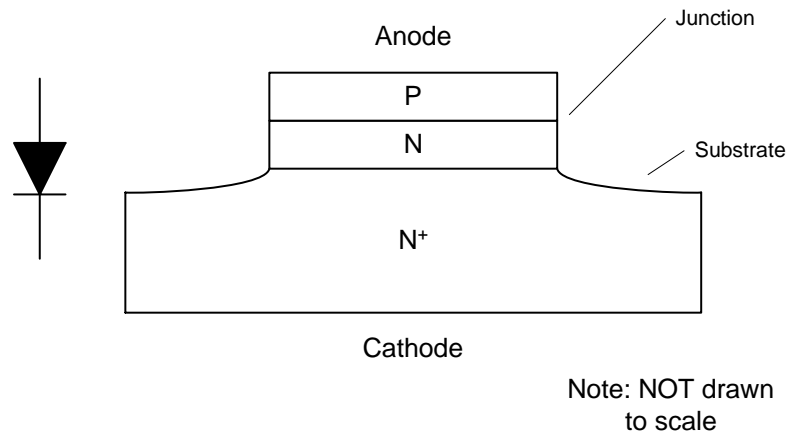

Figure 1 Varactor Diode Cross Section

P & N Layers, Junction & The Depletion Region

The N layer is doped with donor atoms, thereby producing excess electrons which result in a net negative charge. The N layer is in direct contact with the P layer, which is doped with acceptor atoms, thereby producing excess holes and a net positive charge. The N⁺ layer is very heavily doped N type material and can be considered as a mechanically-rugged platform upon which the other layers which form the diode junction are deposited or formed. The N⁺ layer does not figure prominently in the electrical operation of the varactor diode.

The Nuts and Bolts of Tuning Varactors

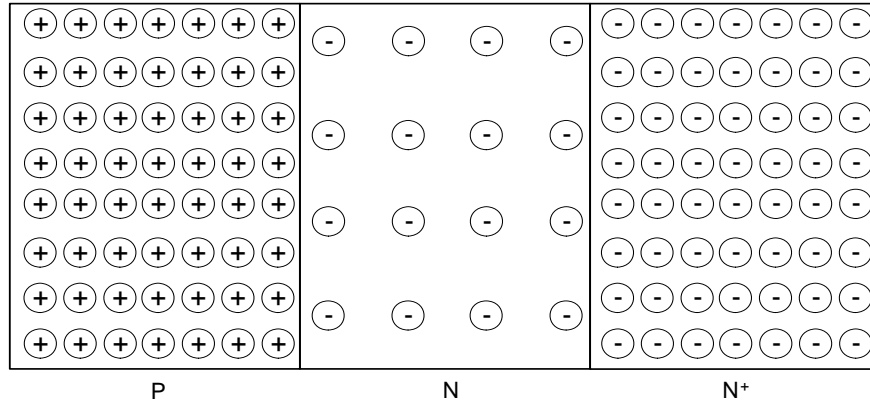

Figure 2 The Layers of a Varactor Diode

In the immediate vicinity of the junction of the P and N layers, excess electrons from the N layer nearest the junction will recombine with holes from the P layer also nearest the junction, forming a volume about the junction of these layers in which no free carriers exist. This region is called the “depletion region”. An electric field exists within this region, since it separates a volume with net negative charge from another with net positive charge. Equilibrium is established when this electric field is sufficiently strong that it restrains diffusion of charge carriers across it. Note that a varactor diode is designed so that the depletion layer extends much farther into the lighter-doped N layer than into the heavily-doped P layer. The depiction in Figure 3 is not to scale, since in practical varactors, by design the edge of the depletion layer that is in the P layer may only extend a few microns from the junction into this layer. The other edge of the depletion layer can extend tens or even hundreds of times farther into the N layer than into the P layer.

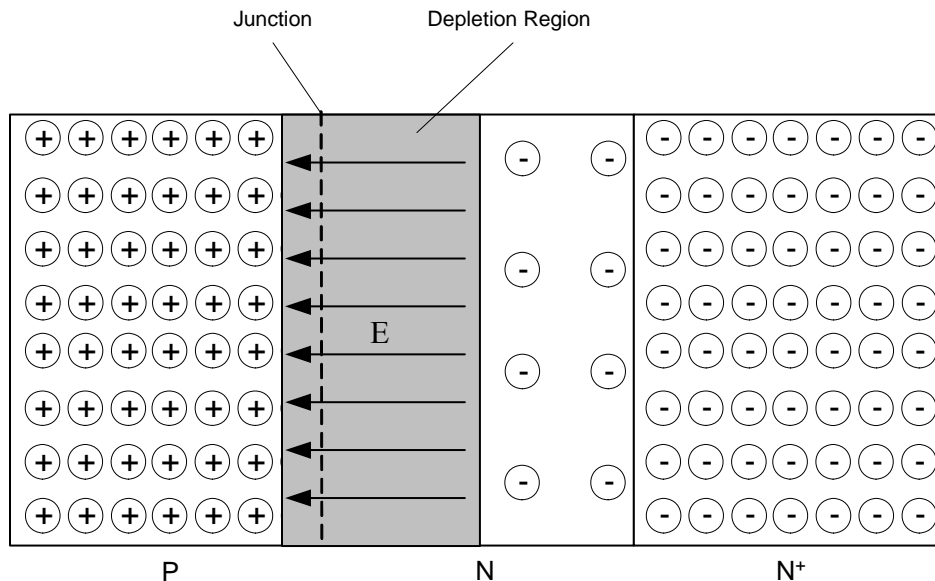

Figure 3 The Varactor Diode Junction and Depletion Region

Built-In Potential

The existence of this electric field results in a voltage, called the “built-in potential” or “contact potential,” across the diode. This polarity of this voltage is in the opposite direction to the

The Nuts and Bolts of Tuning Varactors

direction of charge diffusion: the negative end of the field is in the p layer and vice versa. The magnitude of this voltage is determined by the concentration of dopants in the p and n layers, and the type of semiconductor material which comprises the diode. The contact potential for a typical Si pn diode is approximately 0.7 V, for a typical GaAs diode is 1.2 V, for a Ge diode is 0.3 V, etc.

Breakdown Voltage

When an external voltage source is connected to the diode in reverse-bias (with the negative side of the voltage source connected to the diode p layer and the positive side of the voltage source connected to the n layer) the thickness of the depletion layer increases. As the external voltage magnitude is increased, the depletion layer thickness also increases until one of two breakdown effects occur. The voltage at which breakdown occurs is called “breakdown voltage”, V_B or V_{BR} .

Avalanche breakdown occurs when a thermally-generated free electron charge carrier can acquire enough energy from the externally-applied voltage that when it impacts an atom in the semiconductor crystal it can transfer sufficient energy to electrons in the atom’s valence band to disrupt a covalent bond. These newly-freed electrons also acquire energy from the external voltage source and collide with more atoms, disrupting more bonds. This process is also referred to as “avalanche multiplication.”

Zener breakdown occurs when electrons from covalent bonds are directly torn from these bonds by the externally-applied electric field. No impact of electrons with atoms in the crystal structure is necessary for this type of breakdown. For lightly doped diode layers, such as those in varactor diodes, zener breakdown occurs at higher voltage than that required for avalanche breakdown, so hereafter it can be assumed that references in this paper to breakdown and breakdown voltage refer exclusively to avalanche breakdown.

Junction Capacitance

From the description of the pn junction and its depletion layer, it should be clear that a pn junction meets the definition of a capacitor: two conductors separated by a dielectric. The portions of the doped p and n layers that are not included within the depletion layer can be considered to be conductors. The depletion layer is free of charge carriers, so it forms a nearly ideal dielectric. The distance that separates the two conductors is controlled by the magnitude and polarity of the bias voltage, as well as by the doping concentration of the n layer.

Virtually all varactor diodes are constructed with circular top contacts, so the varactor diode is modeled as a cylindrical section composed of three sections: p layer, dielectric layer and n layer. Then, the capacitance of the diode is given by the familiar formula

$$C_J = \frac{\epsilon A}{d} \quad (1)$$

where

C_J = The junction capacitance of a varactor die
 ϵ = The permittivity of the depletion layer

$\epsilon = \epsilon_R \epsilon_0$
 ϵ_0 = permittivity of free space =
8.849 pF/m
 ϵ_R = relative dielectric constant =
11.8 for Si

A = Area of the circular cross section of the junction
d = Thickness of the depletion region

The Nuts and Bolts of Tuning Varactors

Clearly, the type of material which comprises the diode is not variable, nor is its junction area, so the numerator of the capacitance formula is fixed by the design of the diode. The variable thickness of the depletion layer as controlled by the magnitude of the external reverse bias voltage is responsible for the variable capacitance of the device.

Types Of Varactor Junctions

The doping concentration of physical layers can be controlled to a remarkable degree in modern diodes. In practice, the varactor's P layer is quite heavily doped, to a concentration of approximately 10^{21} atoms/cc, and it is intentionally kept quite thin to minimize its parasitic resistance.

The large majority of the diode total thickness is comprised of its substrate layer, which is a heavily-doped N-type layer (also typically doped to approximately 10^{21} atoms/cc). The cathode layer is another N-type layer, sandwiched between the P layer and the substrate layer, which functions as the cathode of the diode junction. The doping concentration of this layer is typically 3 or more orders of magnitude lower than that of the substrate and is controlled in a tightly prescribed manner to produce one of two types of varactor diode junction: abrupt or hyperabrupt.

Abrupt

In an abrupt junction diode, the doping concentration of the cathode layer with respect to distance from the pn junction is nominally constant, and is normally 3 to 4 orders of magnitude lower than that of the P layer. Consequently, as the magnitude of the reverse bias voltage is increased from 0 V to some value just less than V_B , the lower edge of the depletion layer sweeps through the cathode layer, away from the junction, while the edge that is in the P layer stays relatively fixed.

Hyperabrupt

In a hyperabrupt junction, the carrier concentration in the cathode layer is rapidly reduced as the distance from the junction increases. This allows the edge of the depletion layer in the cathode layer to sweep through its thickness at a much more rapid rate with respect to reverse bias voltage.

The equation that describes C_J as a function of reverse voltage, V_R , is

$$C_J(V_R) = \frac{C_J(V_X)}{\left(\frac{V_R + \phi}{V_X + \phi}\right)^\gamma} \quad (2)$$

where

$C_J(V_R)$	=	Junction capacitance at voltage V_R	$0 \leq V_R < V_B$
$C_J(V_X)$	=	Junction capacitance at voltage V_X	V_X is an arbitrary reference voltage, typically 0 V
ϕ	=	Built-in voltage	$\phi = 0.7$ V for Si
γ	=	Slope exponent	$\gamma = 0.5$ for abrupt junction $\gamma > 0.5$ for hyperabrupt junction

The C_J vs. V_R curves for an abrupt junction die and a hyperabrupt die are shown in Figure 4.

The Nuts and Bolts of Tuning Varactors

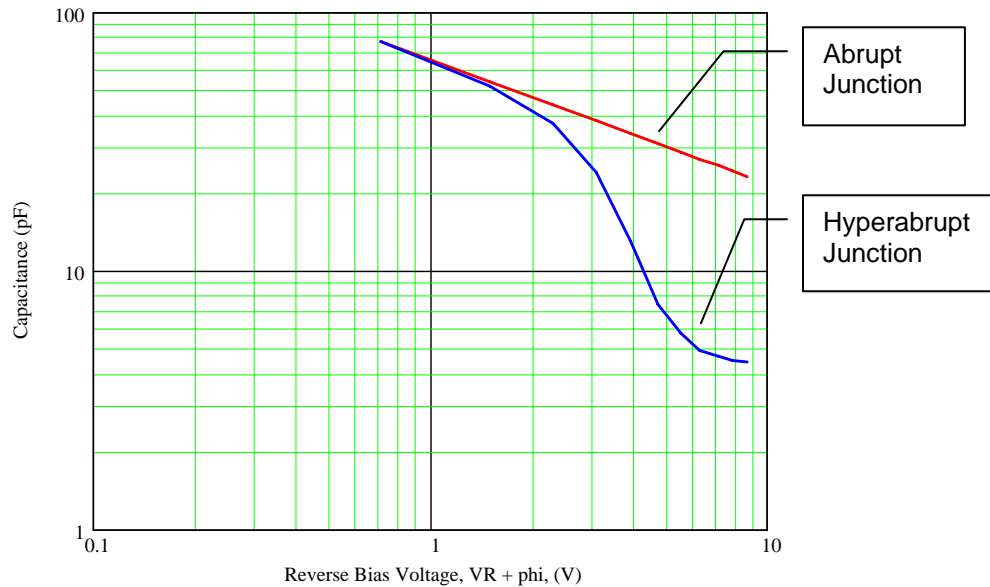

Figure 4 C_J vs. V_R for an Abrupt and a Hyperabrupt Varactor versus $V_R + \phi$

Note that the curves are plotted with respect to the sum of the external bias voltage and the built-in voltage, ϕ . This is appropriate since the actual voltage impressed upon the diode junction is the series combination of the built-in and the external voltages. To determine the capacitance that would be produced as a function of the external voltage alone, simply subtract the built-in voltage from voltage represented on the horizontal axis. For example, both of the curves in Figure 4 start at $V_R + \phi = 0.7$ V, which corresponds to $V_R = 0$ V. Since the logarithm of 0 is undefined, varactor C-V curves are plotted versus $V_R + \phi$ on logarithmic axes and versus V_R on linear axes.

A straight line on a log-log plot indicates a diode whose C_J vs. $V_R + \phi$ curve has constant γ . It is apparent from Figure 4 that the C_J vs. $V_R + \phi$ for the hyperabrupt does not have constant γ . In this case, γ is also a function of the applied reverse bias voltage. This curve can be described by slightly modifying equation 2 as follows

$$C_J(V_R) = \frac{C_J(V_X)}{\left(\frac{V_R + \phi}{V_X + \phi}\right)^{\gamma(V_R)}} \quad (3)$$

The manner in which $\gamma(V_R)$ varies with respect to V_R is determined by the specific doping profile of the cathode layer.

Series Resistance/Q

The equivalent circuit of a varactor die can be quite simple: it is the series combination of the resistance of the substrate N^+ layer, R_{N^+} , the resistance of the undepleted portion of the cathode N layer, R_N , a virtually ideal capacitor produced by the depletion layer, C_J , and the resistance of the heavily doped anode P layer, R_P . This simple circuit is shown in Figure 5.

The Nuts and Bolts of Tuning Varactors

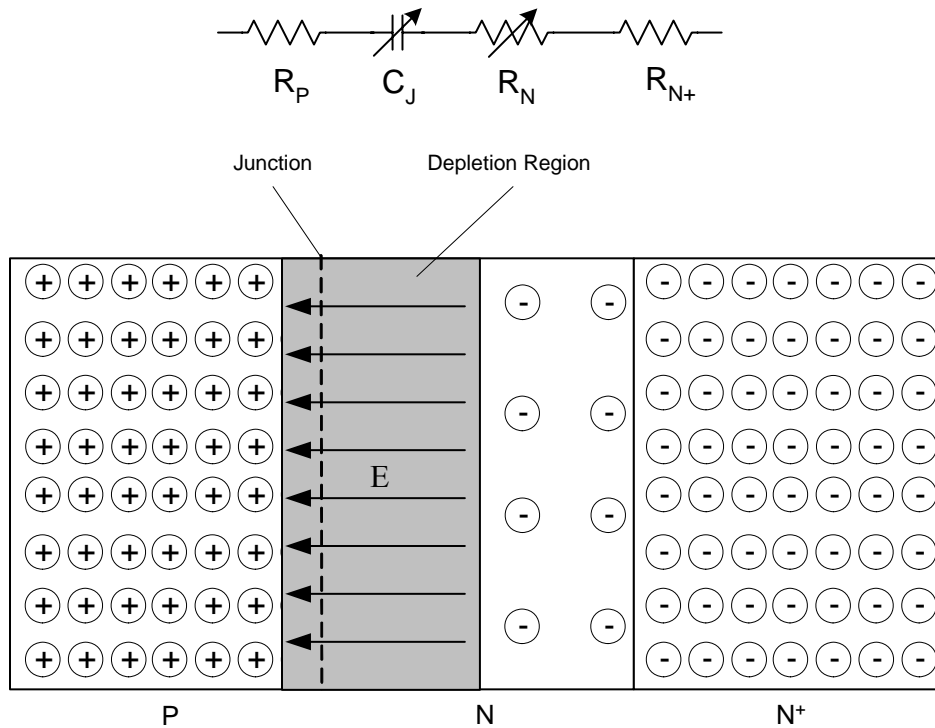

Figure 5 Varactor Simple Series Equivalent Circuit

As discussed previously, the magnitude of an external reverse bias voltage causes the edge of the depletion layer to sweep through the cathode N layer while the edge in the P layer remains virtually stationary. Thus, the value of the P layer resistance remains virtually constant, but the resistance R_N varies indirectly with the thickness of the depletion layer. Since the doping of this layer is lowest of any region of the diode, its resistivity, ρ_N , is by far the highest of the three layers. As a consequence of this property, diode resistance is maximum at very low reverse bias in which case the depletion layer is thinnest ($V_R = 0$ V), and is lowest when the depletion layer occupies the entire thickness of the N layer, assuming that state can occur at a bias voltage less than the breakdown voltage.

The total impedance of this equivalent circuit as a function of reverse bias voltage is the sum of the series resistances and the capacitive reactance of the depletion region capacitance

$$Z_T(V_R) = R_P + R_{N+} + R_N(V_R) - jX_{C_J}(V_R) = R_T(V_R) - jX_{C_J}(V_R) \quad (4)$$

Quality factor, Q , is a figure of merit that expresses the degree to which a reactive component is ideal. This is the ratio of the amount of energy that the device can store in its reactance to the amount of energy it will dissipate in its resistance. For a varactor, this is given by

$$Q = \frac{\text{Energy}_{\text{STORED}}}{\text{Energy}_{\text{DISSIPATED}}} = \frac{\text{Im}(Z_T(V_R))}{\text{Re}(Z_T(V_R))} = \frac{X_{C_J}(V_R)}{R_T(V_R)} = \frac{1}{\omega C_J(V_R) R_T(V_R)} \quad (5)$$

The Nuts and Bolts of Tuning Varactors

In an abrupt junction diode, the doping profile of the N layer is constant. That is, the density of dopant atoms does not vary as distance from the junction increases.

In order to get much larger changes in capacitance versus bias voltage, the doping concentration of a hyperabrupt varactor changes widely as distance from the junction increases, and very rapidly very near the junction. So, the total resistance of a hyperabrupt varactor is generally larger than that of an otherwise equivalent abrupt junction diode; and, the series resistance of a hyperabrupt with low reverse bias voltage can be quite large compared to that of the abrupt junction diode.

In practice, varactor diodes are operated in the region where Q is acceptably high. Of course, this is determined by the properties and intended function of the circuit in which the varactor is used. In most cases, circuits should be designed so that their varactors, especially hyperabrupt junction diodes, are not biased below about 2 V. Given the preponderance of low-voltage battery-powered circuits, this rule of thumb is often ignored.

Q is also an indirectly proportional function of frequency. By convention that originated with limitations of test equipment that is long forgotten, varactor diode manufacturers specify Q measured at 50 MHz, and at some arbitrary bias voltage. To determine the value of Q at a frequency other than 50 MHz, simple manipulation of equation 5 gives

$$Q(f) = Q_{\text{specified}} * \frac{f_{\text{specified}}}{f} \quad (6)$$

for constant V_R .

For example, for a diode whose Q at $V_R = 4$ V and $f = 50$ MHz is 2000, Q at $V_R = 4$ V and $f = 1$ GHz is

$$Q(1\text{GHz}) = Q_{50\text{MHz}} * \frac{50\text{MHz}}{1\text{GHz}} = 2000 * \frac{50e6}{1e9} = 100$$

This equation should be considered as a means to determine the maximum value of Q at a frequency other than that specified by the manufacturer. Practical experience has shown that as frequency increases, the actual measured Q for a varactor diode is typically lower than the value predicted by equation 6. An underlying assumption for Equation 6 is that the only frequency-dependent component of the diode impedance is its reactance, which is increasingly incorrect with increasing frequency, since as frequency increases, the resistance caused by skin effect also increases. **As a practical matter, measuring the total impedance of the diode and then accurately resolving the real from the imaginary components of that impedance can be quite tricky, although methods exist that can make this endeavor worthwhileⁱⁱⁱ.**

Modeling Of Varactors

To this point, the discussion of varactors has been limited to a naked die. For the large majority of applications, varactors must be packaged in one of a seemingly infinite variety of packages (SOT-23, SC-79, SOD-323, etc.) which protect the die from physical damage and also facilitate easy connection of the varactor to the rest of the circuit. Each of these packages has parasitic impedances which affect the performance of the die it contains.

The Nuts and Bolts of Tuning Varactors

Equivalent Circuit Including Package Parasitics

Figure 6 shows a cross-sectional view of an SOD-323 package. In this view the physical elements of the packaged diode assembly that contribute parasitic reactances can readily be seen.

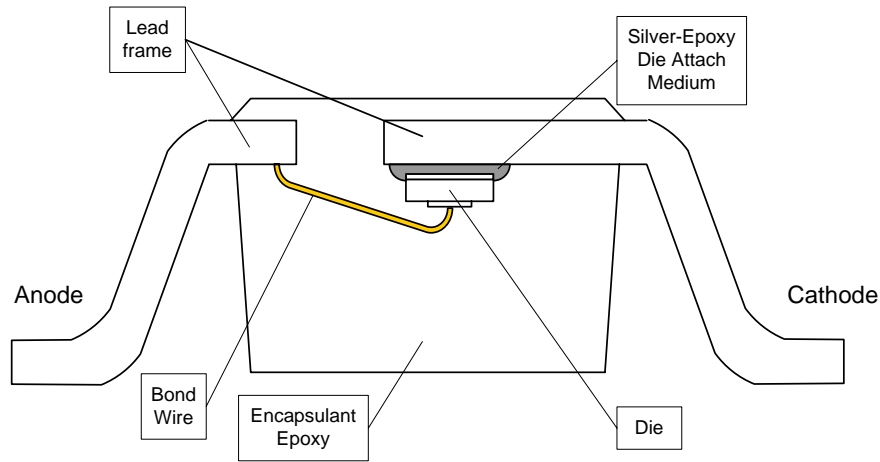

Note: This drawing is NOT TO SCALE. It is intended to illustrate the construction of the SOD-323 package ONLY.

Figure 6 Cross-sectional View of an SOD-323 Diode assembly

Packaged diodes are fortunately rather simple to model: diode packages add some amount of inductance, L_S , which is in series with the die; and, they have some amount of capacitance, C_{pkg} , which is typically modeled as being in parallel with the series combination of the die and the package inductance. This equivalent circuit is shown in the left-hand side of Figure 7. This model contains the most significant elements of the packaged diode, but as one might expect, much more complicated models exist that can be used to produce more accurate performance simulations, but the model below is adequate for most applications.

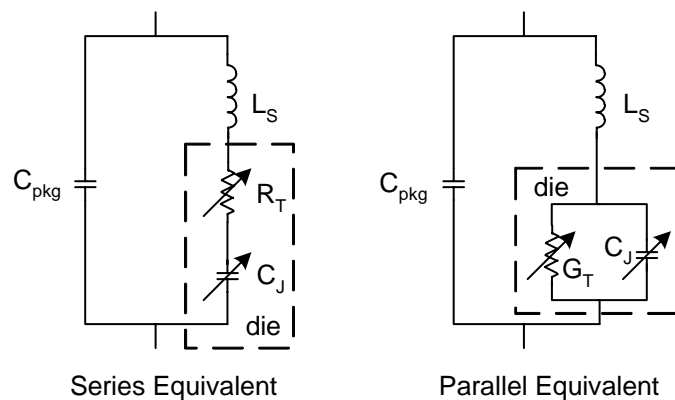

Figure 7 Equivalent Circuits of a Varactor Die in a Package

Alternatively, the diode may be modeled as a parallel combination of the variable junction capacitance and variable conductance. In this case, the junction capacitance and conductance are derived by performing a series-to-parallel conversion on the series equivalent circuit.

The Nuts and Bolts of Tuning Varactors

There are two significant effects of the presence of the package: the parallel package capacitance, C_{pkg} , reduces the overall capacitance ratio available from the diode; and, the presence of the series inductance, L_S , makes series and parallel resonances possible.

Reduction In Available Capacitance Ratio

Assume that the ratio of junction capacitance from $V_R = 2\text{ V}$, C_{J2} , to junction capacitance with $V_R = 12\text{ V}$, C_{J12} , is 2.135, that is, the diode has an abrupt junction ($\gamma = 0.5$). Also, assume that $C_{J12} = 0.3\text{ pF}$. This curve is shown in Figure 7.

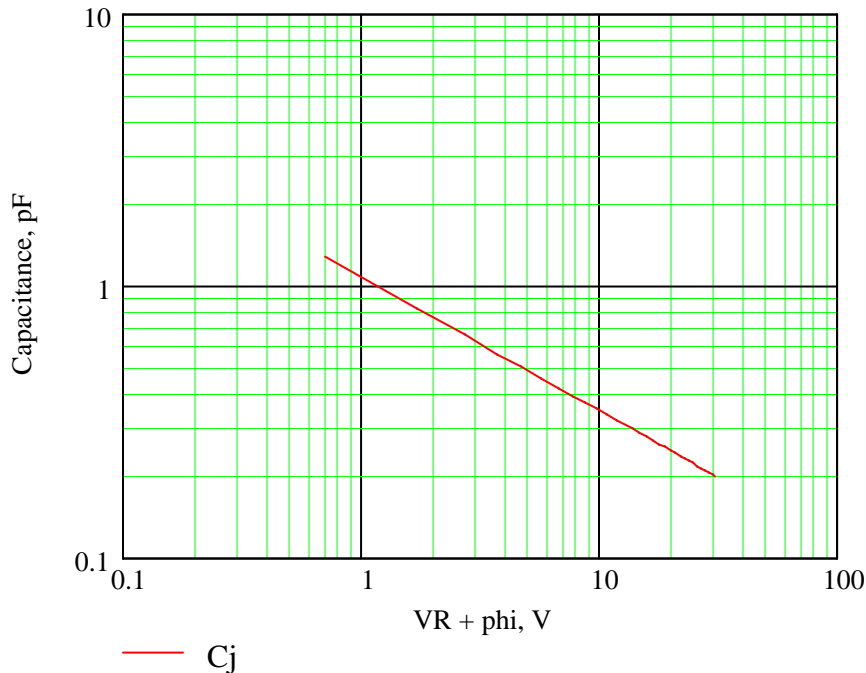

Figure 7 Junction Capacitance versus $V_R + \phi$

Now, assume that this die is placed into a package whose series inductance is 1.2 nH and its package capacitance is 0.2 pF. If total capacitance, C_T , which is defined as the capacitance measured between the packaged diode leads, is measured at a sufficiently low frequency that the reactance of L_S is not significant, then the total capacitance is the junction capacitance in parallel with the package capacitance. The C_T versus $V_R + \phi$ curve for this device is shown in Figure 8.

There is an obvious consequence of packaging the diode. The total capacitance ratio, measured from C_{T2} to C_{T12} is only 1.69, compared to a junction capacitance ratio over the same voltage range of 2.135. This results in a substantial reduction in the bandwidth that the packaged diode can tune a resonant circuit, compared to that of the naked die version.

The reduction of available capacitance ratio is related to the relative magnitudes of the parasitic package capacitance (or any other fixed capacitance in parallel with the die) and the minimum junction capacitance of the die^{iv}. This ratio of total capacitance is related to the ratio of junction capacitance by

The Nuts and Bolts of Tuning Varactors

$$\frac{C_{TV1}}{C_{TV2}} = \left[\frac{1}{1+r} \right] \left[\frac{C_{JV1}}{C_{JV2}} + r \right] \quad (7)$$

where

- C_{TV1} = Total capacitance with $V_R = V1$
- C_{TV2} = Total capacitance with $V_R = V2$
- C_{JV1} = Junction capacitance with $V_R = V1$
- C_{JV2} = Junction capacitance with $V_R = V2$
- r = Ratio of package capacitance to minimum junction capacitance $r = C_{pkg}/\text{minimum } C_J$

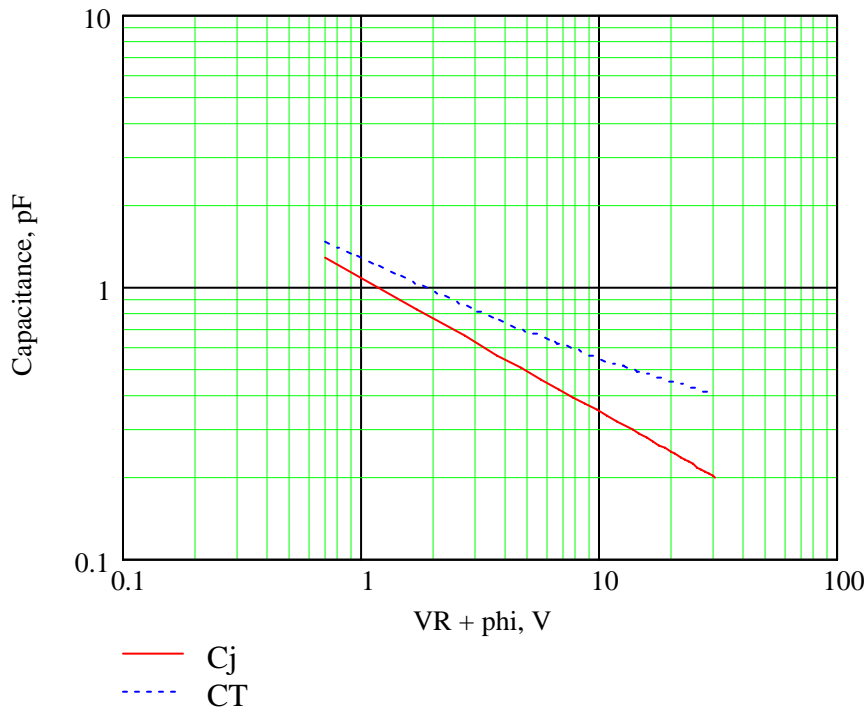

Figure 8 Junction and Total Capacitance versus $V_R + \phi$

The available total capacitance ratio normalized to junction capacitance ratio versus r is shown in Figure 9. We can see that the reduction in total capacitance ratio is most severe for very small junction capacitance and is negligible for large die capacitance.

The Nuts and Bolts of Tuning Varactors

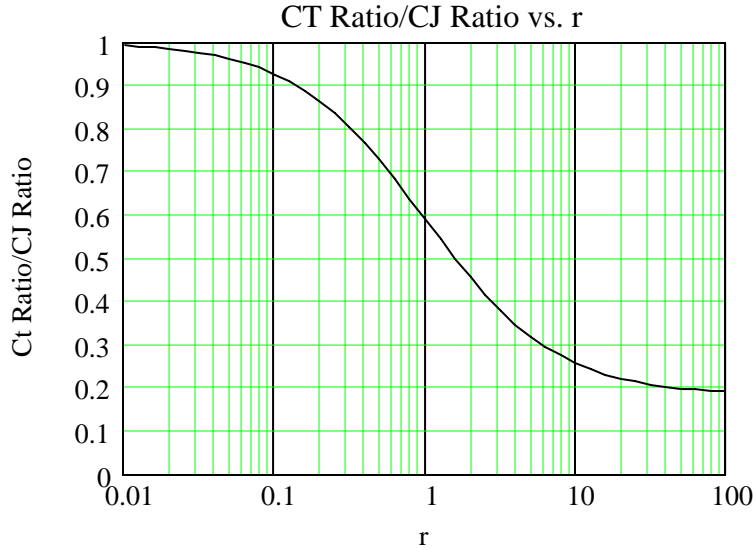

Figure 9 Total Capacitance Ratio Normalized to Junction Capacitance Ratio versus r

Self Resonance

Series or parallel resonance, which results from the die and package capacitances interacting with the package series inductance, can cause unexpected circuit performance.

Consider the packaged diode parallel equivalent circuit shown in the right-hand side of Figure 7. The impedance for this circuit is the parallel combination of the C_{pkg} with the series network of L_S , R_T and C_J , which is

$$Z_T = \frac{(R_T + jX_{L_S} - jX_{C_J})(-jX_{C_{pkg}})}{R_T + j(X_{L_S} - X_{C_J} - X_{C_{pkg}})} \quad (8)$$

$$= \frac{R_T X_{C_{pkg}}^2}{R_T^2 + (X_{L_S} - X_{C_J} - X_{C_{pkg}})^2} - j \frac{R_T^2 X_{C_{pkg}} + [(X_{L_S} - X_{C_J})X_{C_{pkg}}(X_{L_S} - X_{C_J} - X_{C_{pkg}})]}{R_T^2 + (X_{L_S} - X_{C_J} - X_{C_{pkg}})^2}$$

Assume that a varactor such as SMV1417-001, an single abrupt junction die packaged in the SOT-23 package, has been selected to tune a VCO that must operate at approximately 1.6 GHz. Also assume that the remainder of the VCO resonator is designed such that the SMV1417-001 must produce 6.6 pF to tune the VCO to 1.6 GHz. At first analysis, this is reasonable; the SMV1417 will require a bias voltage of approximately 7.73 V, which will also produce relatively low series resistance in the undepleted cathode N layer. For the SOT-23 package, $L_S \approx 1.5$ nH and $C_{pkg} \approx 0.13$ pF. Figure 10 shows the real and imaginary parts of the total diode impedance versus frequency.

At the bias voltage that was calculated to produce 6.6 pF, it is clear from Figure 10 that the SMV1417-001 is series-self-resonant at 1.6 GHz. Under this bias voltage, the VCO resonator will not be tuned to operate at 1.6 GHz as originally expected, since the diode cannot produce the capacitive reactance required to resonate with the other reactive components within the resonator circuit. The impedance of the diode in this condition is actually a small resistance, rather than the

The Nuts and Bolts of Tuning Varactors

capacitive reactance that is desired. Possible remedies for this situation include redesign of the resonator circuit to allow the varactor diode to produce a capacitance that is larger than that required to produce self resonance, selection of the same die in a package which has different parasitic reactance values, etc.

Fortunately, the first parallel self resonance occurs above 11 GHz so this mode is generally of no concern if we make the relatively safe assumption that the active device in the VCO has little or no gain at that frequency, so no spurious oscillations are likely to occur at that frequency.

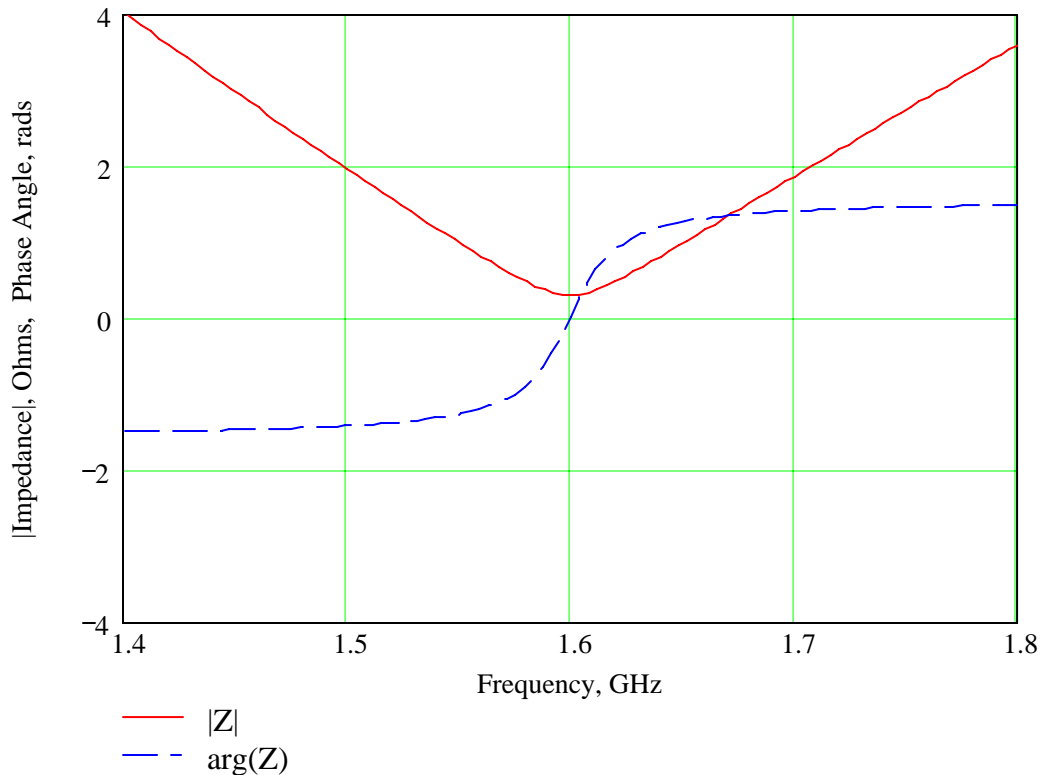

Figure 10 SMV1417-001 Impedance versus Frequency, $V_R \approx 7.7$ V

General pn Diode Model

Abrupt junction varactors are relatively well represented by the pn junction model widely in use in such CAD systems as ADS, Microwave Office, SPICE, et al, since γ for an abrupt junction diode remains constant versus applied reverse bias voltage. The standard pn diode model provided by most simulator packages can typically be used as-is, employing the default values for all components of the model with the exception of C_{J0} , V_B and γ , (which is often called "M" in simulator models) for which the values appropriate for the diode of interest are utilized. Of course, the accuracy of simulation is enhanced if the designer can supply actual values for as many diode model parameters as possible.

The hyperabrupt junction diode is more complicated to model, since in most hyperabrupt varactors γ is not constant but is a function of reverse bias voltage. The capacitance versus

The Nuts and Bolts of Tuning Varactors

voltage curve of a non-constant- γ varactor can be approximated very closely in a piecewise manner.

The piecewise approach can offer a better capacitance versus voltage fit at the expense of more initial involvement by the designer. The capacitance versus voltage curve is analyzed and modeled iteratively, on each section of the C-V curve. These sections can be described with linear equations, or with a modified form of Equation 2, which is shown as Equation 9, below.

$$C_J(V_R) = \frac{C_{J0}}{\left(1 + \frac{V_R}{V_J}\right)^M} + C_{pkg} \quad (9)$$

In this approach, values of $C_J(V_R)$, V_R , V_J and M are selected to produce curves that coincide with some portion of the actual, measured diode C-V curve. This approach is described in Skyworks Solutions Ap Notes APN1005 and APN1006 (available at www.skyworksinc.com). Figure 11 shows the measured and fitted C-V curves for SMV1265-011. The values used for the variables are:

Voltage Range, V_R (V)	C_{J0} (pF)	M (also known as γ)	V_J (V)	C_{pkg} (pF)
0–2.5	22.5	2.0	4.00	0.00
2.5–6.5	21.0	25.0	68.00	0.00
6.5–11	20.0	7.3	14.00	0.90
≥ 11	20.0	1.8	1.85	0.56

Table 1 Variable Values for Piecewise Approximation of C-V Curve for SMV1265-011

The curves that correspond to these approximations are shown in Figure 12. Note that the values in the Voltage Range column of Table 1 refer to V_R , rather than $V_R + \phi$.

It is also noteworthy that in this approach, the values utilized for C_{J0} , M , V_J and C_{pkg} do not necessarily correspond to physical features of the diode or its package, but are selected with the sole purpose of reconstructing various portions of the measured C-V curve.

The Nuts and Bolts of Tuning Varactors

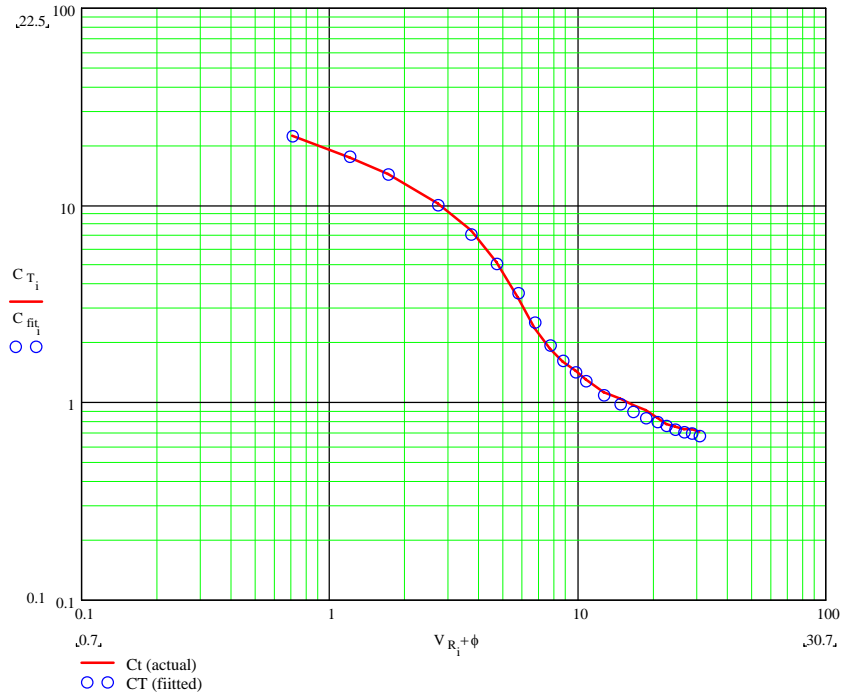

Figure 11 SMV1265-011 Actual and Fitted C_T vs. $V_R + \phi$

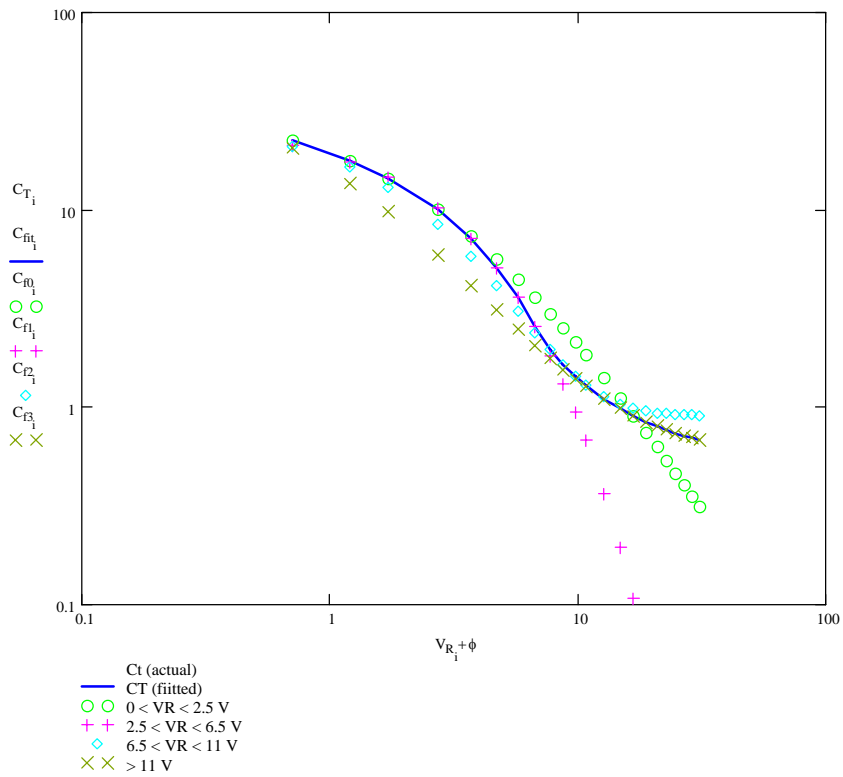

Figure 12 SMV1265-011 Piecewise C-V Curves

The Nuts and Bolts of Tuning Varactors

Conclusion

This paper described the operation of tuning varactor diodes. Properties such as junction type, series resistance, capacitance versus voltage were discussed, along with the effects of the parasitic reactances presented by diode packages. A piece-wise linear approximation method to improve the accuracy of hyperabrupt diode computer simulations was described.

ⁱ S. M. Sze, "Semiconductor Devices Physics and Technology", John Wiley & Sons, 1985, Chapter 3

ⁱⁱ J. Millman, "Microelectronics", McGraw-Hill, 1979, Chapter 2

ⁱⁱⁱ G. Stauffer, "Finding the Lumped Element Varactor Diode Model", High Frequency Electronics, November 2003

^{iv} R. Cory, "The Effects of Package Capacitance on the Capacitance vs. Voltage Characteristic of a Tuning Varactor", RF Design, 1991/1992 Directory