

Silicon Crossover Ring Quad Schottky Diode

BAT 15-099R

- Low barrier diode for double balanced mixers, phase detectors and modulators

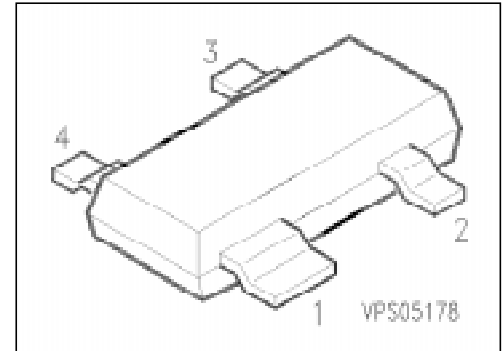

ESD: Electrostatic discharge sensitive device, observe handling precautions!

Type	Marking	Ordering Code (tape and reel)	Pin Configuration	Package ¹⁾
BAT 15-099R	S6	Q62702-A0043	<p>EHA07012</p>	SOT-143

Maximum Ratings per Diode

Parameter	Symbol	Values	Unit
Forward current	I_F	110	mA
Power dissipation, $T_s \leq 70\text{ °C}$	P_{tot}	100	mW
Storage temperature range	T_{stg}	- 55 ... + 150	°C
Operating temperature range	T_{op}	- 55 ... + 150	

Thermal Resistance per Diode

Junction – ambient ²⁾	$R_{th JA}$	≤ 1020	K/W
Junction – soldering point	$R_{th JS}$	≤ 780	

¹⁾ For detailed information see chapter Package Outlines.

²⁾ Package mounted on alumina 15 mm × 16.7 mm to 0.7 mm.

Electrical Characteristics per Diode
at $T_A = 25\text{ }^\circ\text{C}$, unless otherwise specified.

Parameter	Symbol	Values			Unit
		min.	typ.	max.	
Forward voltage $I_F = 1\text{ mA}$ $I_F = 10\text{ mA}$	V_F	–	0.23 0.32	–	V
Forward voltage matching ¹⁾ $I_F = 10\text{ mA}$	ΔV_F	–	–	20	mV
Diode capacitance $V_R = 0, f = 1\text{ MHz}$	C_T	–	0.38	–	pF
Forward resistance $I_F = 10\text{ mA} / 50\text{ mA}$	R_F	–	5.5	–	Ω

Forward current $I_F = f(V_F)$

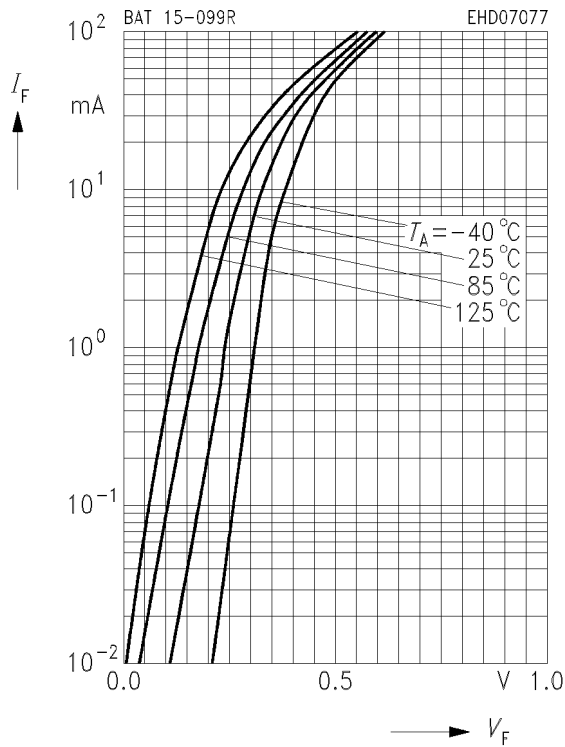

Forward current $I_F = f(T_S; T_A^*)$

*Package mounted on alumina

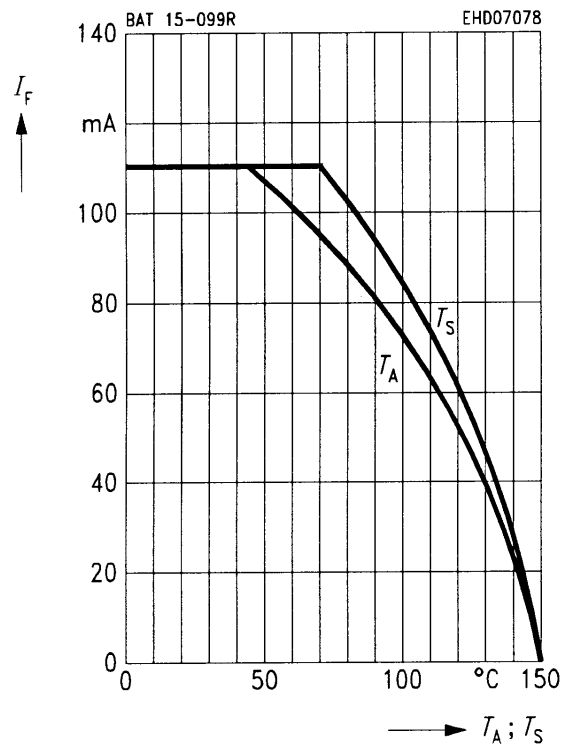

1) ΔV_F is the difference between the lowest and the highest V_F in the component.