

Terabit/Second Transmission Experiments

A. R. Chraplyvy and R. W. Tkach, *Senior Member, IEEE*

(Invited Paper)

Abstract—This paper discusses the reasons for the recent acceleration in the exponential growth rate of single-fiber transmission capacity. The various transmission experiments with capacities of 1 Tb/s and greater are reviewed.

Index Terms—Optical fiber communication.

THE PROGRESS in lightwave transmission capacity in single-mode fibers is summarized in Fig. 1. This figure not only summarizes past progress but serves as a useful tool for extrapolating future trends. There are two sets of points. The solid symbols represent laboratory results while the open symbols show progress in commercially deployed systems. The solid lines are merely guides for the eye. There are three different categories of points represented in Fig. 1. Squares represent single-channel electronic time-division-multiplexed (ETDM) results, triangles represent wavelength-division-multiplexed (WDM) results, and circles show the results of optical time-division multiplexing (OTDM) experiments (no OTDM commercial applications have been demonstrated). Several general trends should be noted. First of all, prior to 1994, the advances in both experimental results and commercial systems grew exponentially at a rate of about 1.8 dB per year with the commercial results lagging experimental results by about six years. Extrapolation of these trends predicted laboratory demonstrations of terabit/s transmission experiments in the year 2003. Second, although the results showed a general exponential growth, the ETDM and WDM experimental results exhibited slower growth in the early parts of this decade. The “droop” in the ETDM results was due to the well-known electronic bottleneck, whereas the slow growth in the WDM arena was due to economic reasons (cost of replicating transmission equipment for each wavelength channel) and to nonlinearities associated with high-bit-rate WDM in dispersion-shifted fibers (DSF). As a result of two developments, in 1994 the slope of the progress in experimental results showed a dramatic increase, to about 4.3 dB per year. A new laboratory technique was introduced, which dramatically reduced the cost of many-channel WDM experiments. In addition, dispersion management became practical with the invention of nonzero dispersion fiber with either positive or negative dispersion. Consequently, the first terabit/s transmission experiments were reported at

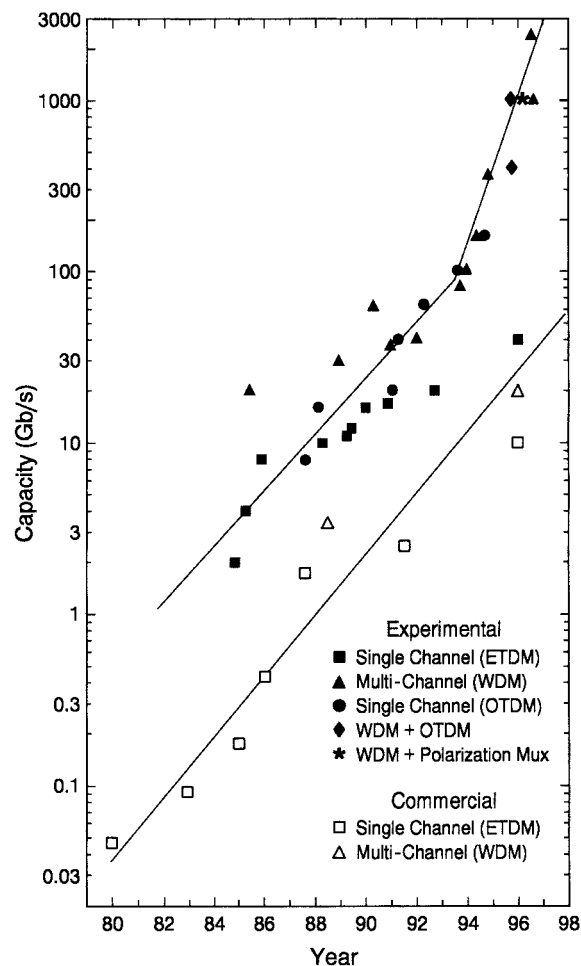

Fig. 1. Transmission capacity through single-mode fibers as a function of year.

the Optical Fiber Conference in San Jose in 1996 [1]–[3], about seven years “ahead of schedule.” This paper describes the developments that led to an explosion in capacity of experimental transmission results, leading to the first terabit/s results. The various terabit/s experiments are then described in some detail.

One of the most daunting aspects of ultrahigh-capacity transmission experiments is the vast amount of equipment required. The experiments described in this paper use tens to more than one hundred laser sources, each carrying modulation at 20 Gb/s or higher. In an actual system, each laser would require its own modulator and data source. To duplicate this equipment for research experiments would be prohibitive both in cost and effort, which is at least part of the reason that

Manuscript received February 17, 1998; revised July 30, 1998.

A. R. Chraplyvy is with Bell Laboratories, Lucent Technologies, Crawford Hill Laboratory, Holmdel, NJ 07733-0400 USA.

R. W. Tkach is with AT&T Labs-Research, Newman Springs Laboratory, Red Bank, NJ 07701-7033 USA.

Publisher Item Identifier S 0018-9197(98)08211-6.

extensive WDM transmission experiments were uncommon before the early 1990's, a notable exception being a system demonstration involving 100 distributed feedback (DFB) lasers frequency-shift keyed by direct modulation at 622 Mb/s [4]. Apart from this heroic effort, there are few examples of very high channel-count experiments. When bit rates of 10 Gb/s and above are desired, the difficulty and expense of obtaining modulated sources increase. Most transmission experiments at these rates use external modulation with LiNbO₃ modulators. The minimal wavelength dependence of these devices suggests a simple expedient for research transmission experiments: pass all the channels through a single modulator, impressing data on all the wavelengths at once. Thus, a single data source and modulator can serve for an arbitrary number of channels [5].

There is one major issue regarding the validity of this approach to simulating actual systems with independent channels. The channels emerging from the modulator all carry the identical data in perfect synchronism. This is far from a realistic scenario; ideally, there should be no correlation between the data in the various channels. Most experiments using this approach have used fiber with sufficient chromatic dispersion to provide time delay of one or more bit intervals between the channels which serves to decorrelate the data. Some experiments have used two optical modulators driven by independent data sources each serving for half the channels, either the even or odd numbered ones [6]. In this way, adjacent channels are independent. A case can also be made that for some possible impairments, such as four-photon mixing (FPM), the worst behavior is seen when the channels are all identical. A good test of the validity of the approach is to look for differences in performance with decorrelation and without. This technique reduces the problem of obtaining a large number of high-speed signals at a defined set of wavelengths to simply obtaining optical sources at those wavelengths and passing them all through a single high-speed modulator. When the number of channels approaches or even exceeds 100, this is an invaluable simplification.

A more fundamental limitation facing ultrahigh-capacity transmission experiments arises from the Scylla and Charybdis of fiber properties: chromatic dispersion and optical nonlinearity [7]. Dispersion limits the bit rates achievable in a single optical channel according to the relation:

$$B^2 DL < 104000$$

where B is the bit rate in gigabit/second, D is the fiber chromatic dispersion (ps/nm/km), and L is the fiber length in kilometers. For conventional single-mode fiber with dispersion of 17 ps/nm/km, this leads to a limitation in the length of 10-Gb/s systems of roughly 60 km. Alternatively, systems of 1000 km in conventional fiber are limited to 2.5 Gb/s. The development of DSF promised to remove this limitation, by redesigning the fiber index profile to generate a waveguide dispersion which cancels the material dispersion at the operating wavelength (typically 1550 nm). But this solution steers away from only one of the twin impairments. Fibers with near-zero chromatic dispersion unfortunately provide an ideal medium for phase-matched generation of new optical waves via FPM [8]. For example, in a typical DSF, with a core area of 55 μm^2 ,

three signals propagating over just 100 km will result in an interference-to-signal ratio for the center channel of $0.01 \times P_{\text{in}}^2$, where P_{in} is the signal input powers in milliwatts. Thus, input signals of only 1-mW peak power will suffer a 1-dB power penalty from FPM interference, so that while high-speed single-channel transmission works well in very low-dispersion fibers, increased capacity using wavelength multiplexing is essentially proscribed. One is left with the choice of either using low dispersion to allow high speed, and foregoing WDM, or using high dispersion to suppress nonlinearity and allow WDM, but be unable to transmit high-speed channels. This apparent closing of the route to high capacity prevented high-speed WDM systems from being demonstrated until the early 1990's.

There is, however, a way to steer a course between these impairments without being squeezed between them. The relevant parameter for high-speed performance is the total dispersion of a link, while nonlinearities are suppressed by the local value of dispersion in the transmission fiber. If transmission fibers can be selected such that the local dispersion always exceeds some minimum value, while the average dispersion of the entire link is kept small, high-speed WDM is enabled. This technique has been called "dispersion management" [9], [10]. The critical advance required for this was the invention of a fiber with negative chromatic dispersion. Before dispersion compensating fiber was widely available, the only fiber with negative chromatic dispersion was nonzero dispersion-shifted fiber (NZDSF) [11]. There are two types of NZDSF, one with dispersion-zero wavelength below about 1520 nm, the other with dispersion-zero wavelength above about 1580 nm. The latter exhibits negative dispersion in the operational band of erbium-doped amplifiers.

The technique of dispersion management was first demonstrated in 1993 [9] in an experiment transmitting eight channels at 10 Gb/s through a dispersion map consisting of long segments of fiber with a dispersion of -2 ps/nm/km compensated by shorter lengths of conventional unshifted single-mode fiber (USF) with dispersion of $+17$ ps/nm/km. A number of other possible dispersion maps have been explored [8]: alternating segments of positive and negative NZDSF; segments of positive NZDSF compensated with DCF; segments of USF compensated with DCF. Alternatively, dispersion compensation can be accomplished with chirped fiber gratings [12]. A critical parameter in such dispersion maps is the period of the dispersion variations. If this period is short compared to the phase-matching length, there is little suppression of mixing [8]. If, however, the period is too long, the interaction of dispersion and self-phase modulation becomes a problem. The optimal value of this parameter remains in doubt and probably varies with system parameters. But it is clear that the alternation period should be longer than about 10 km.

Together, these two innovations—modulating many channels with one modulator, and dispersion management to suppress fiber nonlinearities with high local chromatic dispersion, while keeping the total dispersion low—have enabled the inflection point in the curve of single-fiber capacity versus time (Fig. 1). The next section will describe the recent experiments demonstrating 1-Tb/s capacity and beyond.

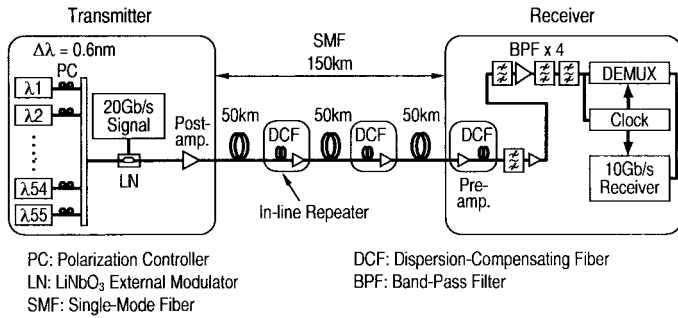

Fig. 2. Schematic diagram of the Fujitsu 1.1-Tb/s WDM experiment.

I. TERABIT/S TRANSMISSION EXPERIMENTS

This section describes the five reported terabit/s transmission experiments [1]–[3], [13]–[16]. Two experiments, one by Fujitsu [1] and the other by NEC [15], were WDM experiments. The AT&T Bell Labs experiment [2], [13] combined WDM with polarization multiplexing. Two experiments by NTT [3], [14], [16] combined optical time-division multiplexing (OTDM) with WDM.

A. Fujitsu

Fig. 2 shows the experimental diagram of the 55-channel WDM experiment [1]. Forty-six DFB lasers and nine external-cavity lasers (ECL’s) were tuned to 0.6-nm (75 GHz) spacings between 1531.7 and 1564 nm. All 55 wavelengths were modulated by one LiNbO₃ modulator producing 20-Gb/s NRZ signals with a pseudo-random bit stream (PRBS) word length of 2²³ – 1. The chirp parameter of the Mach–Zehnder modulator was set to $\alpha = -1$ to provide some pulse compression during propagation. No decorrelating fiber was used. However, the signals were injected into a USF ($\lambda_0 = 1.3 \mu\text{m}$) transmission fiber that decorrelates the data in the first 6 km. The signals were transmitted through three 50-km spans of unshifted fibers with average dispersion of 15.2 ps/nm/km and average dispersion slope of 0.064 ps/nm²/km. After each 50-km span but before amplification, the dispersion was compensated by dispersion-compensating fiber (DCF). The dispersion map of the three spans is shown in Fig. 3. The dispersion characteristics of the DCF fibers were –103 ps/nm/km dispersion with a dispersion slope of –0.18 ps/nm²/km. The effective dispersion slope of the entire transmission span was 0.039 ps/nm²/km and all channels experienced positive dispersion. About 10 dB of power pre-emphasis [17], [18] was required to achieve equal signal-to-noise ratios (SNR’s) at the receiver. The variation in receiver sensitivities of the 55 channels was about 3 dB.

B. AT&T Bell Labs

The experimental diagram is shown in Fig. 4 [13]. The outputs of 25 lasers were multiplexed using star couplers and waveguide grating routers. The wavelengths ranged from 1542 to 1561.2 nm with 100-GHz channel spacing. All lasers were ECL’s except for channel 16 which used a DFB laser. The multiplexed wavelengths were then amplified and propagated through a polarization beamsplitter (PBS) to align all the polarizations. Polarization controllers at the output of each laser (not

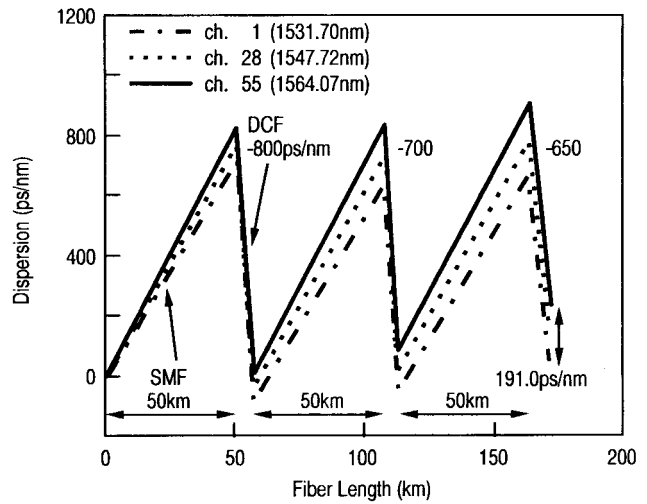

Fig. 3. Accumulated dispersion as a function of length in the 1.1-Tb/s Fujitsu experiment.

shown in the figure) allowed independent polarization control for each source. The 25 copolarized wavelengths were split by a 3-dB coupler, passed through beam expanders to allow blocking of the two polarizations independently, separately modulated by LiNbO₃ Mach–Zehnder modulators with zero chirp, and then recombined with orthogonal polarizations in a PBS. Two different RF tones were superimposed on the two modulators to facilitate polarization demultiplexing at the receiver, as discussed later. The modulators had a small-signal bandwidth of 18 GHz and built-in polarizers. The 20-Gb/s NRZ drive signals were produced by electronically multiplexing two 10-Gb/s 2¹⁵ – 1 PRBS signals using a commercial gallium arsenide multiplexer. To decorrelate the bit patterns of the two polarization channels at each wavelength, the outputs of the two modulators traversed different lengths of fiber before polarization multiplexing. To decorrelate the modulation on the different WDM channels in each polarization, the bit streams were temporally dispersed after polarization multiplexing by transmission through USF. The 50 decorrelated 20-Gb/s signals propagated through 55 km of NZDSF [10] with a zero-dispersion wavelength of 1513 nm and a dispersion slope of 0.07 ps/nm²/km. Transmission through multiple amplified spans was not attempted because there already was a noticeable SNR penalty after one span. No intentional pre-emphasis was used in this experiment because the amplifiers used in the experiment were flat-gain amplifiers. The channels were polarization demultiplexed using a polarization beamsplitter and adjusting the polarization controller to null the RF tone present in the unwanted polarization. The wavelengths were demultiplexed by a commercial grating filter with 4-dB insertion loss. The signals were detected with two commercial pin-based optical-to-electrical (O/E) converters. The output of one O/E was used for clock recovery and the output of the other was electronically demultiplexed to two 10-Gb/s bit streams in a dual-gate FET circuit. The sensitivities of the 50 channels had a variation of 4 dB.

Modest polarization-dependent loss (PDL) in the transmission path is not detrimental to system performance. Systems

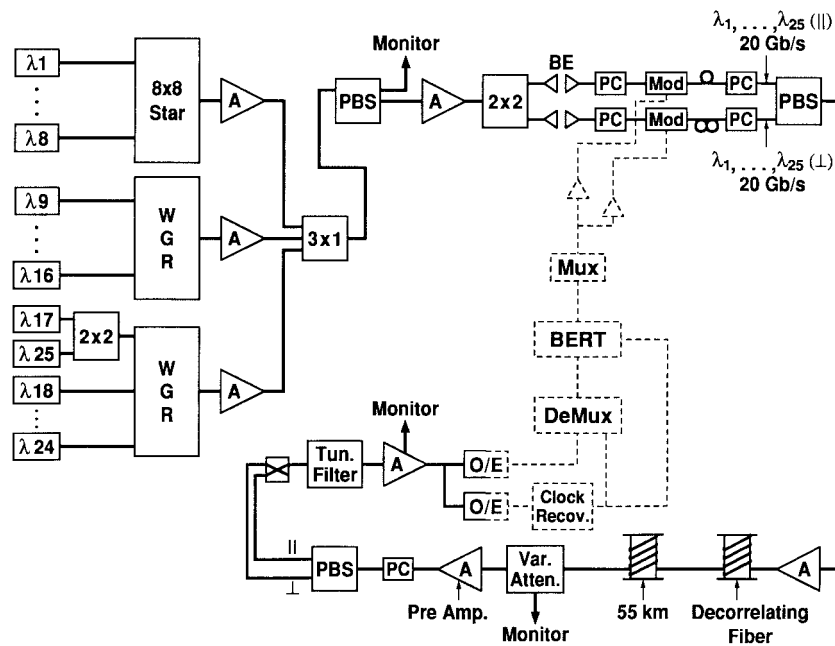

Fig. 4. Experimental diagram. Not shown are individual polarization controllers for each laser. WGR: waveguide router; PBS: polarization beamsplitter; A: optical amplifier; BE: beam expander; PC: polarization controller; Mod: modulator; O/E: optoelectronic converter; Var. Atten.: variable attenuator; Tun. Filter: tunable filter; BERT: bit-error rate detector; Mux: electronic multiplexer; DeMux: electronic demultiplexer.

with higher PDL require two PBS at the receiver. The received optical signal is split by a 3-dB coupler (not shown in Fig. 4) and the outputs from this splitter then pass through polarizers which are set to block light from the undesired polarizations. These polarizers will not be aligned for maximum transmission of the desired polarization when there is polarization-dependent loss in the transmission line. This results in some loss for the desired polarization. However, since this loss occurs after the optical preamplifier, there need not be an impact on receiver sensitivity. This receiver design can compensate for a rather large degree of polarization-dependent loss. As long as the multiplexed signals have not become copolarized, they can in principle be separated. In practice, it should be possible to accommodate polarization-dependent losses up to several decibels.

C. NTT

There were two NTT experiments based on OTDM/WDM [3], [16], the first a 10-channel 100-Gb/s-per-channel experiment, and more recently a seven-channel 200-Gb/s-per-channel experiment. The experimental diagram of the 1-Tb/s experiment is shown in Fig. 5. A low-noise supercontinuum (SC) broad-band source was developed for OTDM/WDM experiments [19]. The output of the SC generator was filtered with an arrayed-waveguide grating (AWG) DEMUX/MUX which produces channels spaced by 400 GHz. Ten of the WDM channels were modulated by a common 10-Gb/s LiNbO₃ modulator ($2^{15} - 1$ PRBS wordlength) but did not employ a decorrelating fiber. As described above, it is not clear how correlated channels impact the transmission results using DSF's. The 10-Gb/s signals were optically time-division-multiplexed to 100 Gb/s using a 10X planar lightwave circuit. After amplification to 5 dBm per channel, the OTDM/WDM

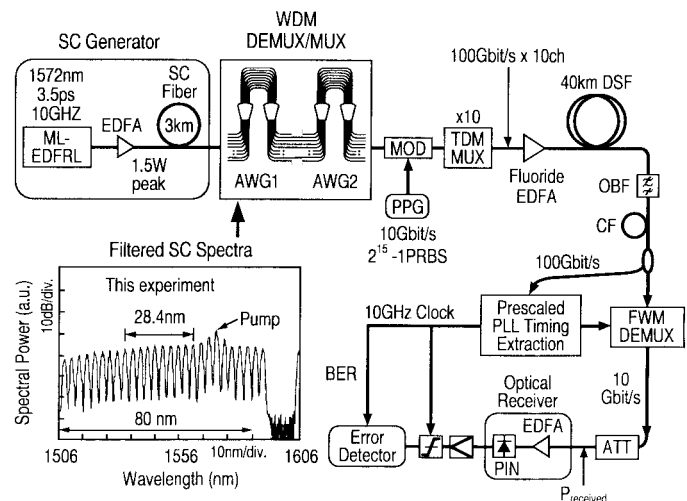

Fig. 5. Schematic diagram of the NTT 10 × 100-Gb/s OTDM-WDM experiment.

signals were transmitted through 40 km of DSF with λ_0 at 1561.3 nm. The 3.5-ps pulses injected into the transmission fiber were broadened during transmission and recompressed after transmission using varying lengths of unshifted fiber. After demultiplexing, the 100-Gb/s signals were injected into a prescaled PLL timing extraction circuit and an all-optical time-domain demultiplexer based on FPM that was timed by the extracted clock from the PLL. The receiver sensitivities departed from baseline sensitivities by up to 9 dB partly due to SNR degradations in the FPM demultiplexer.

The 1.4-Tb/s experiment used the same experimental techniques. The seven 200-Gb/s channels were spaced by 600 GHz and were transmitted through 50 km of DSF. In this experiment, the receiver sensitivities varied from baseline sensitivity

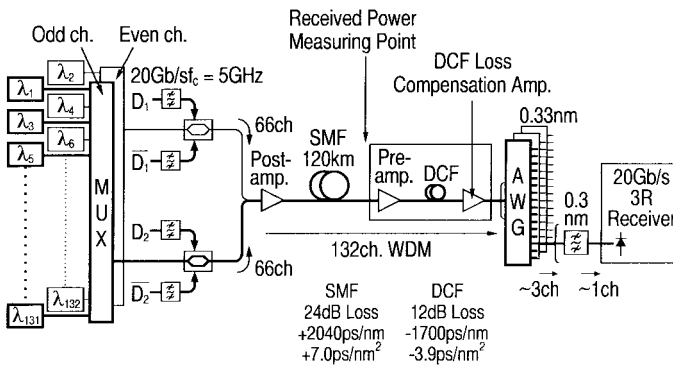

Fig. 6. Schematic diagram of the NEC 2.64-Tb/s WDM experiment.

by up to 8 dB. In this case, the penalty was attributed to pulse broadening caused by filtering in the receiver.

D. NEC

Another strictly WDM experiment achieved a total capacity of 2.64 Tb/s [15]. Fig. 6 shows the experimental diagram of 132 lasers each modulated at 20 Gb/s using optical duobinary coding. To produce the duobinary signals, 20-Gb/s binary signals were precoded and converted to three-level duobinary signals by electrically filtering the modulator drive signals with 5-GHz Bessel–Thompson low-pass filters. The original binary signals are recovered after optical detection. Such severe filtering of the drive signals permits very close channel spacings, in this case 33 GHz. The penalty for using this modulation format is that only short PRBS word lengths could be transmitted at 20 Gb/s. Recently, duobinary modulation schemes that can support $2^{31} - 1$ PRBS word lengths have been implemented [20] that do not rely on heavy filtering of the drive signals, but it is not clear whether this format allows the same channel packing density.

The 132 channels occupied the wavelength range between 1529 and 1563.9 nm. The injected power into the 120-km unshifted transmission fiber was on average 0 dBm/channel. Pre-emphasis was used to equalize the output powers of all channels. After preamplification, DCF was used to compensate the dispersion of the transmission fiber. The channels had residual dispersion between 240 and 380 ps/nm/km. After demultiplexing, the channels were detected by a 20-Gb/s 3R receiver identical to receivers used for traditional NRZ signals. Penalties relative to baseline sensitivity varied from 0 to 3 dB and were attributed to SNR degradation during the multiplexing process and differences in the pre-amplifier operating conditions.

While each of these experiments seems heroic in the sense that extraordinary measures have been taken to reach these high capacities, they do indicate trends that are being adopted in systems which are closer to deployment. All of these experiments have sought to increase spectral efficiency—a trend that is now appearing in the form of channel spacings as small as 50 GHz in commercial systems. All of these experiments used very large optical bandwidths, beyond the flat region of typical EDFA’s available at the time and incorporating the entire gain bandwidth. The experiments described here

were limited to small numbers of amplifiers due to the large gain variations across this bandwidth. Recently, gain-flattened amplifiers have appeared and been used in systems of more modest capacity, but with several amplified spans [21]. Finally, all of these experiments used modulation at 20 Gb/s or higher. In constructing such an experiment, it is essential to operate at the highest available speed simply to minimize the number of lasers required, or alternatively to maximize the capacity given equipment constraints. However, in deployed systems, the optimal choice of modulation rate from the perspective of maximizing capacity is still unclear. There is still work to be done optimizing the tradeoffs between optical multiplexing technology and laser stabilization for smaller channel spacing on the one hand, and the difficulties of high-speed electronics and precise dispersion compensation in the presence of fiber nonlinearity for very high bit rates on the other.

APPENDIX

During the publication process, several other terabit/s transmission experiments have been reported. This section will briefly summarize these experiments. Two of the experiments [22], [23] were the first to demonstrate terabit/s transmission over multi-hundred-kilometer distances and exploiting L-band amplification. The Lucent experiment [22] transmitted 100 WDM channels each operating at 10 Gb/s through 400 km of dispersion-managed NZDSF using $2^{31} - 1$ PRBS word length. The NTT experiment [23] transmitted 50 WDM channel each operating at 20 Gb/s ($2^7 - 1$ PRBS) through 600 km of dispersion-compensated unshifted fiber in a loop configuration.

Two Lucent experiments [24], [25] were demonstrated at 40-Gb/s line rate. The first (30×40 Gb/s, $2^{23} - 1$ PRBS) used 85 km of dispersion-managed nonzero-dispersion fiber. The second (35×40 Gb/s, $2^{23} - 1$ PRBS) used 85 km of dispersion-compensated unshifted fiber.

REFERENCES

- [1] H. Onaka, H. Miyata, G. Ishikawa, K. Otsuka, H. Ooi, Y. Kai, S. Kinoshita, M. Seino, H. Nishimoto, and T. Chikama, “1.1 Tb/s WDM transmission over a 150 km 1.3 μm zero-dispersion single-mode fiber,” in *Optical Fiber Conf.*, San Jose, CA, 1996, paper PD19.
- [2] A. H. Gnauck, A. R. Chraplyvy, R. W. Tkach, J. L. Zyskind, J. W. Sulhoff, A. J. Lucero, Y. Sun, R. M. Jopson, F. Forghieri, R. M. Derosier, C. Wolf, and A. R. McCormick, “One terabit/s transmission experiment,” in *Optical Fiber Conf.*, San Jose, CA, 1996, paper PD20.
- [3] T. Morioka, H. Takara, S. Kawanishi, O. Kamatani, K. Takiguchi, K. Uchiyama, M. Saruwatari, H. Takahashi, M. Yamada, T. Kanamori, and H. Ono, “100 Gbit/s × 10 channel OTDM/WDM transmission using a single supercontinuum WDM source,” in *Optical Fiber Conf.*, San Jose, CA, 1996, paper PD21.
- [4] H. Toba, K. Oda, K. Nakanishi, N. Shibata, K. Nosu, N. Takato, and M. Fukuda, “A 100-channel optical FDM transmission/distribution at 622 Mb/s over 50 km,” *J. Lightwave Technol.*, vol. 8, pp. 1396–1401 1990.
- [5] A. H. Gnauck, A. R. Chraplyvy, R. W. Tkach, and R. M. Derosier, “160 Gbit/s (8 × 20 Gbit/s WDM) 300 km transmission with 50 km amplifier spacing and span-by-span dispersion reversal,” *Electron. Lett.*, vol. 30, pp. 1241–1243, 1994.
- [6] N. S. Bergano, C. R. Davidson, B. M. Nyman, S. G. Evangelides, J. M. Darcie, J. D. Evankow, P. C. Corbett, M. A. Mills, G. A. Ferguson, J. A. Nagel, J. L. Zyskind, A. J. Lucero, and A. A. Klein, “40-Gb/s WDM transmission of eight 5-Gb/s data channels over transoceanic distances using the conventional NRZ modulation format,” in *Optical Fiber Communications Conf. (OFC ’96)*, San Diego CA, 1995, postdeadline paper PD-19.

- [7] F. Forghieri, R. W. Tkach, and A. R. Chraplyvy, "Fiber nonlinearities and their impact on transmission systems," in *Optical Fiber Telecommunications*, T. L. Koch and I. P. Kaminow, Eds. New York: Academic, 1997, vol. IIIA.
- [8] R. W. Tkach, A. R. Chraplyvy, F. Forghieri, A. H. Gnauck, and R. M. Derosier, "Four-photon mixing and high-speed WDM systems," *J. Lightwave Technol.*, vol. 13, pp. 841–849, 1995.
- [9] A. R. Chraplyvy, A. H. Gnauck, R. W. Tkach, and R. M. Derosier, " 8×10 Gb/s transmission through 280 km of dispersion-managed fiber," *IEEE Photon. Technol. Lett.*, vol. 5, pp. 1233–1235, 1993.
- [10] C. Kurtzke, "Suppression of fiber nonlinearities by appropriate dispersion management," *IEEE Photon. Technol. Lett.*, vol. 5, pp. 1250–1252, 1993.
- [11] L. Clark, A. A. Klein, and D. W. Peckham, "Impact of fiber selection and nonlinear behavior on network upgrade strategies for optically amplified long interoffice routes," in *Proc. NFOEC'94*, San Diego, CA, 1994, pp. 123–132.
- [12] M. J. Cole, H. Geiger, R. I. Laming, S. Y. Set, M. N. Zervas, W. H. Loh, and V. Gusmeroli, "Continuously chirped, broadband dispersion-compensating fiber gratings in a 10-Gbit/s, 110-km standard fiber link," in *Eur. Conf. Optical Communications (ECOC '96)*, Oslo, Norway, 1996, paper Th.B.3.5.
- [13] A. R. Chraplyvy, A. H. Gnauck, R. W. Tkach, J. L. Zyskind, J. W. Sulhoff, A. J. Lucero, Y. Sun, R. M. Jopson, F. Forghieri, R. M. Derosier, C. Wolf, A. R. McCormick, "One terabit/s transmission experiment," *IEEE Photon. Technol. Lett.*, vol. 8, pp. 1264–1266, 1996.
- [14] T. Morioka, H. Takara, S. Kawanishi, O. Kamatani, K. Takiguchi, K. Uchiyama, M. Saruwatari, H. Takahashi, M. Yamada, T. Kanamori, and H. Ono, "1 Tbit/s (100 Gbit/s \times 10 channel) OTDM/WDM transmission using a single supercontinuum WDM source," *Electron. Lett.*, vol. 32, pp. 906–907, 1996.
- [15] Y. Yano, T. Ono, T. Ito, H. Yamazaki, M. Yamaguchi, and K. Emura, "2.6 Terabit/s WDM transmission experiment using optical duobinary coding," *Eur. Conf. Optical Communication*, Oslo, Norway, 1996, paper ThB.3.1.
- [16] S. Kawanishi, H. Takara, K. Uchiyama, I. Shake, O. Kamatani, and H. Takahashi, "1.4 Tbit/s (200 Gbit/s \times 7 ch) 50 km optical transmission experiment," *Electron. Lett.*, vol. 33, p. 1716, 1997.
- [17] A. R. Chraplyvy, J. A. Nagel, and R. W. Tkach, "Equalization in amplified WDM lightwave transmission systems," *IEEE Photon. Technol. Lett.*, vol. 4, pp. 920–922, 1992.
- [18] A. R. Chraplyvy, R. W. Tkach, K. C. Reichmann, P. D. Magill, and J. A. Nagel, "End-to-end equalization experiments in amplified WDM lightwave systems," *IEEE Photon. Technol. Lett.*, vol. 5, pp. 428–429, 1993.
- [19] S. Kawanishi, "200 Gbit/s, 100 km TDM transmission using supercontinuum pulses with prescaled PLL timing extraction and all-optical demultiplexing," *Electron. Lett.*, vol. 31, pp. 816–817, 1995.
- [20] T. Franck, P. B. Hansen, T. N. Nielsen, and L. Eskildsen, "Novel duobinary transmitter," in *Proc. Eur. Conf. Optical Communications*, Edinburgh, U.K., 1997, p. 1.67.
- [21] Y. Sun, J. B. Judkins, A. K. Srivastava, L. Garret, J. L. Zyskind, J. W. Sulhoff, C. Wolf, R. M. Derosier, A. H. Gnauck, R. W. Tkach, J. Zhou, R. P. Espindola, A. M. Vengsarkar, and A. R. Chraplyvy, "Transmission of 32-WDM 10-Gb/s channels over 640 km using broadband, gain flattened erbium-doped silica fiber amplifiers," *IEEE Photon. Technol. Lett.*, vol. 9, pp. 1652–1654, 1997.
- [22] A. K. Srivastava, Y. Sun, J. W. Sulhoff, C. Wolf, M. Zirngibl, R. Monnard, A. R. Chraplyvy, A. A. Abramov, R. P. Espindola, T. A. Strasser, J. R. Pedrazzani, A. M. Vengsarkar, J. L. Zyskind, J. Zhou, D. A. Ferrand, P. F. Wysocki, J. B. Judkins, and Y. P. Li, "1 Tb/s transmission of 100 WDM 10 Gb/s channels over 400 km of TrueWave fiber," in *Optical Fiber Conf.*, San Jose, CA, 1998, paper PD-10.
- [23] S. Aisawa, T. Sakamoto, M. Fukui, J. Kani, M. Jinno, and K. Oguchi, "Ultra-wide band, long distance WDM transmission demonstration: 1 Tb/s (50 \times 20 Gb/s), 600 km transmission using 1550 and 1580 nm wavelength bands," in *Optical Fiber Conf.*, San Jose, CA, 1998, paper PD-11.
- [24] C. D. Chen, I. Kim, O. Mizuhara, T. V. Nguyen, K. Ogawa, R. E. Tench, L. D. Tzeng, and P. D. Yeates, "1.2-Tb/s WDM transmission experiment over 85 km fiber using 40 Gb/s line rate transmitter and 3R receiver," in *Optical Fiber Conf.*, San Jose, CA, 1998, paper PD-21.
- [25] C. D. Chen, I. Kim, O. Mizuhara, T. V. Nguyen, K. Ogawa, R. E. Tench, L. D. Tzeng, and P. D. Yeates, "1.4 Tb/s (35 ch \times 40 Gb/s) WDM transmission experiment over 85 km standard single-mode fiber," in *Optoelectronics and Communications Conf.*, Chiba, Japan, 1998, paper PD1-2.

A. R. Chraplyvy, photograph and biography not available at the time of publication.

R. W. Tkach (M'84–SM-98), photograph and biography not available at the time of publication.