

Kako preživeti zimo z električnim avtomobilom?

prof. dr. Matjaž Vidmar

Torek, 24.4.2018 ob 17.00 v P1



IKT LSO



Moj oče

Ivo Vidmar

1923 – 2010

dipl. ing. energetik



Pipistrel Sinus 912

5l/100km
@180km/h
bencin 95

2002-danes
>2500h

>15 let
brez okvar!

Ford model T - 1914



Cessna model 172 - 1955



Muzejska vozila so neučinkovita, potratna in nevarna!

Ulica Sergeja Mašere 21, 5000 Nova Gorica
 Tržaška cesta 25, 1000 Ljubljana

Dodaj cilj

Možnosti poti ZAPRI

Izogni se Dolžinske enote

- Avtoceste Samodejno
- Cestnine milje
- Trajekti km

Pošljite navodila v telefon

prek H4 in A1 1 h 6 min
 1 h 2 min po praznih cestah 103 km
 Ta pot vključuje cestnine.

[PODRBNOСТИ](#)

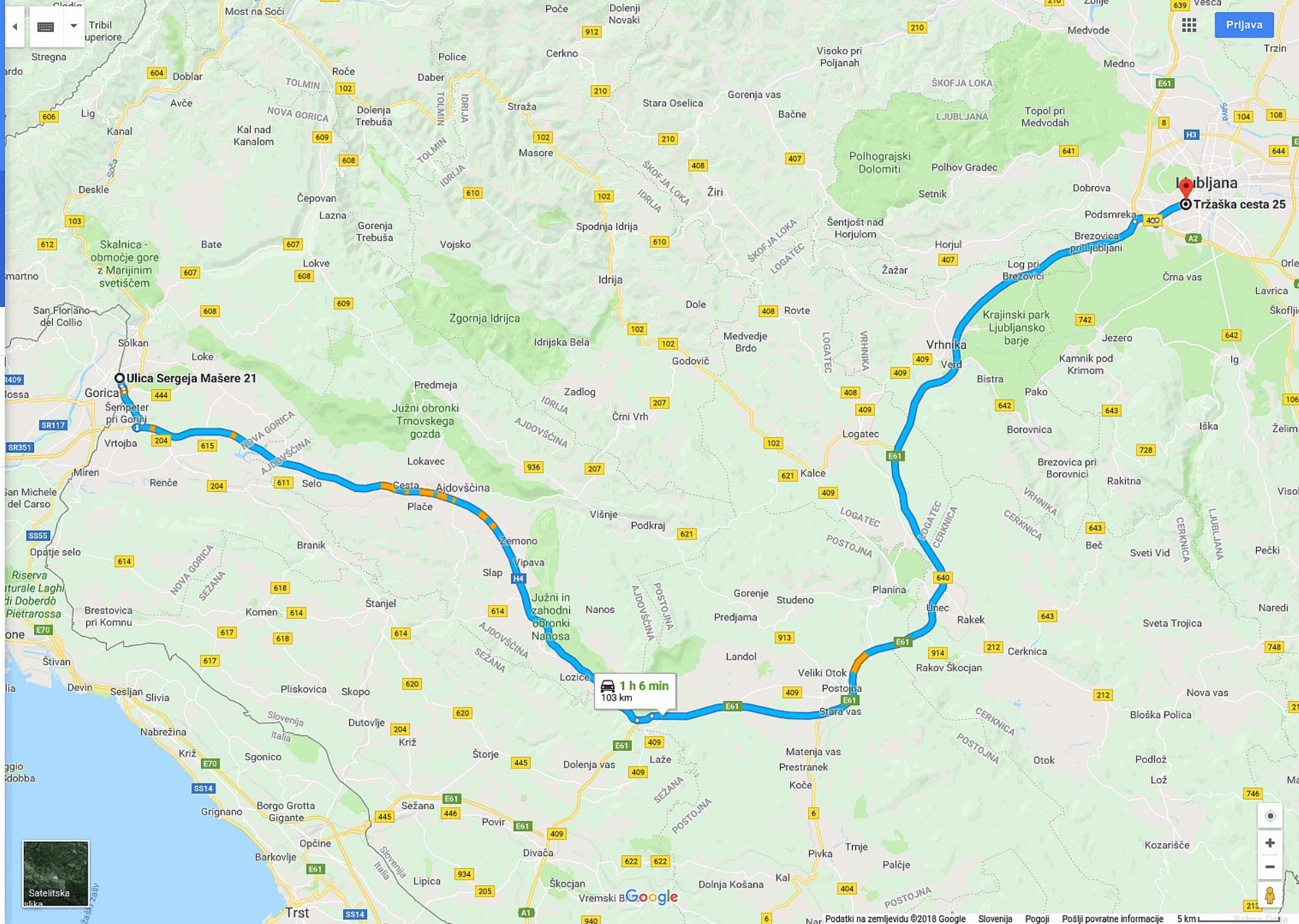

Avtocesta

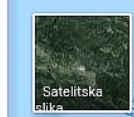

Ulica Sergeja Mašere 21, 5000 Nova Gorica

Tržaška cesta 25, 1000 Ljubljana

Dodaj cilj

Možnosti poti

Izogibaj se

- Avtoceste
- Cestnine
- Trajekti

Dolžinske enote

- Samodejno
- milje
- km

ZAPRI

Pošljite navodila v telefon

prek Kalce - Col 1 h 48 min 87,0 km

1 h 42 min po praznih cestah

[PODROBNOSTI](#)

prek Dornberk - Štanjel 2 h 11 min 115 km

2 h po praznih cestah

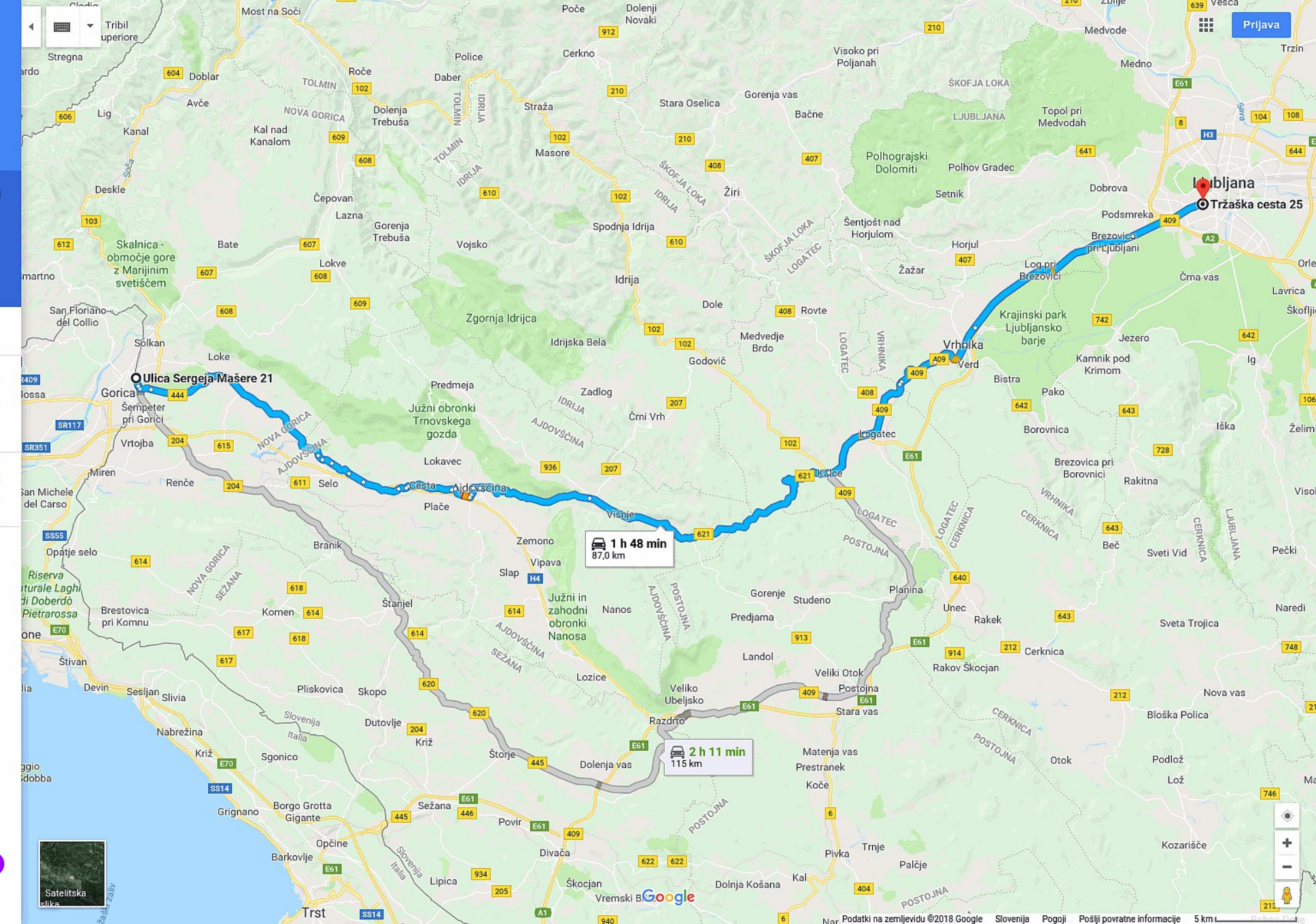

Prevrnjeni tovornjaki?

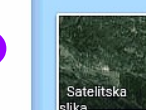

1 h 48 min 87,0 km

2 h 11 min 115 km



Opel Kadett
E (Daewoo
Racer kopija)

poraba
7l/100km
osvinčen 98

1987-2007

380000km
uničen od rje!

Nevarno vozilo:
ESP vsebuje hude napake,
vožnja po snegu ni možna kljub 4x4
ABS ne dovoli zaviranja po prvem zdrsu



Novinarji: avto leta 2001...

Audi A4
4x4 2.5l

poraba
7l/100km
diesel

2001-2005

Številne
napake
in okvare!



Kia Rio

poraba
6l/100km
bencin 95

2007-danes

315000km+

>11 let
brez okvar!

Električno vozilo čez 10 let?

Nicolas Léonard Sadi Carnot 1824

$$\eta = \frac{W}{Q_V} \leq 1 - \frac{T_{\text{HLADNO}}}{T_{\text{VROČE}}}$$

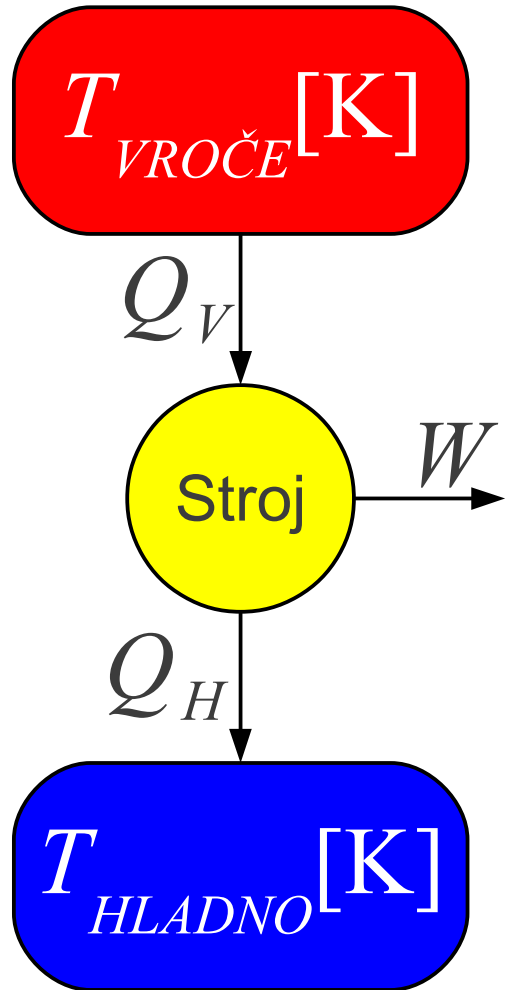

Nadzvočno letalo Concorde $\eta \equiv 5\%$

Parna lokomotiva $\eta \approx 8\%$

Potniško letalo $\eta \equiv 15\%$ (visoka hitrost!)

Bencinski motor $\eta \approx 20\%$ (optimalna moč)

Dieselski motor $\eta \approx 25\%$ (optimalna moč)

Jedrska elektrarna $\eta \approx 30\%$

Avto na vodik $\eta \approx 30\%$ ($\eta \approx 60\%$ $\text{CH}_4 \rightarrow \text{H}_2$)

X $\eta \approx 50\%$ gorivne celice)

Termoelektrarna $\eta \approx 40\%$

Baterijski avto $\eta \approx 40\%$ (termoelektrarna)

Sodobno malo letalo $\eta \equiv 50\%$ (bencin)

- Avtomobilsko industrijo zanima samo dobiček
- Brezumno fanatično varčevanje pri gradnji avtov
- Tržišče je nasičeno z vozili na fosilna goriva:
iskanje novih izdelkov in prisilen umik starih
- Električni avto je cenejši za proizvodnjo
- Avtomobilska industrija ne zasluži s trženjem goriva
- Industrija lahko zasluži s trženjem baterij
- Industrija ne zasluži s servisiranjem izdelkov
- Električni avto ima malo obrabljivih delov:
celoten servis pri vulkanizerju
- Izdelek brez možnosti servisiranja je cenejši
za proizvodnjo (primer televizorji, računalniki)

Avto na metan → nova panoga turistične industrije!

Bencinski motor
lepo teče
na metan
(ne cuka)

Ogromne
jeklenke
200bar
poseben
vplinjač!



Jacques Cousteau &
Émile Gagnan 1943
izumila športno
potapljanje! (\$\$\$)

Proizvodnja vodika

$\eta \approx 60\%$

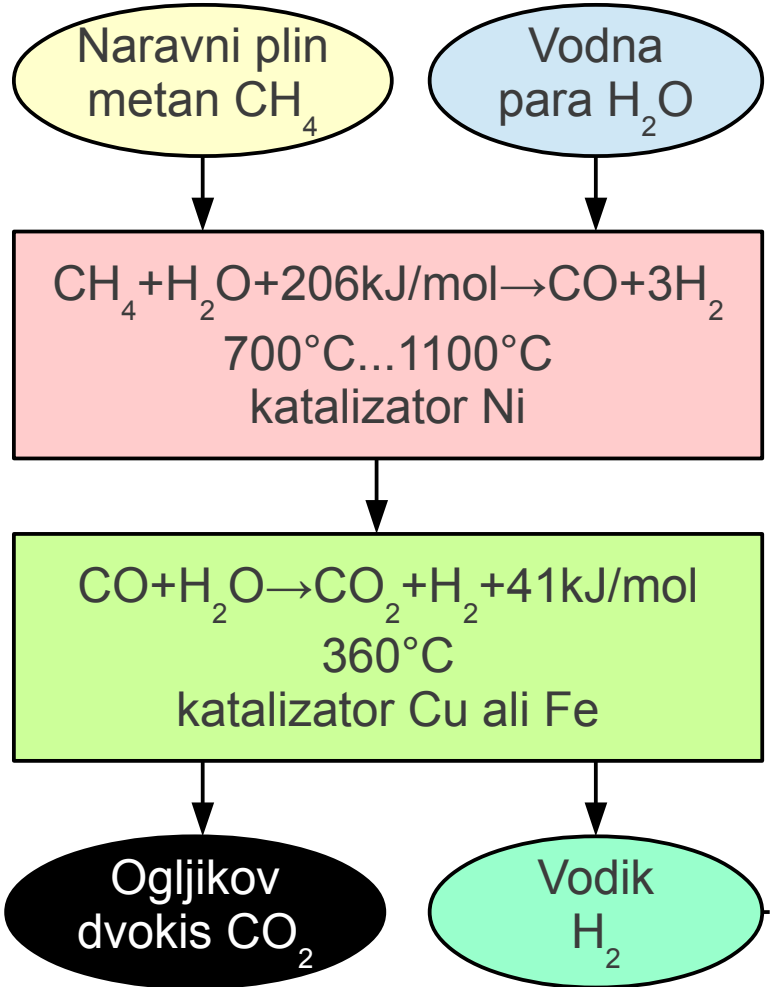

9...12kg CO₂ ← 1kg H₂

Avto na vodik $\eta \approx 50\%$

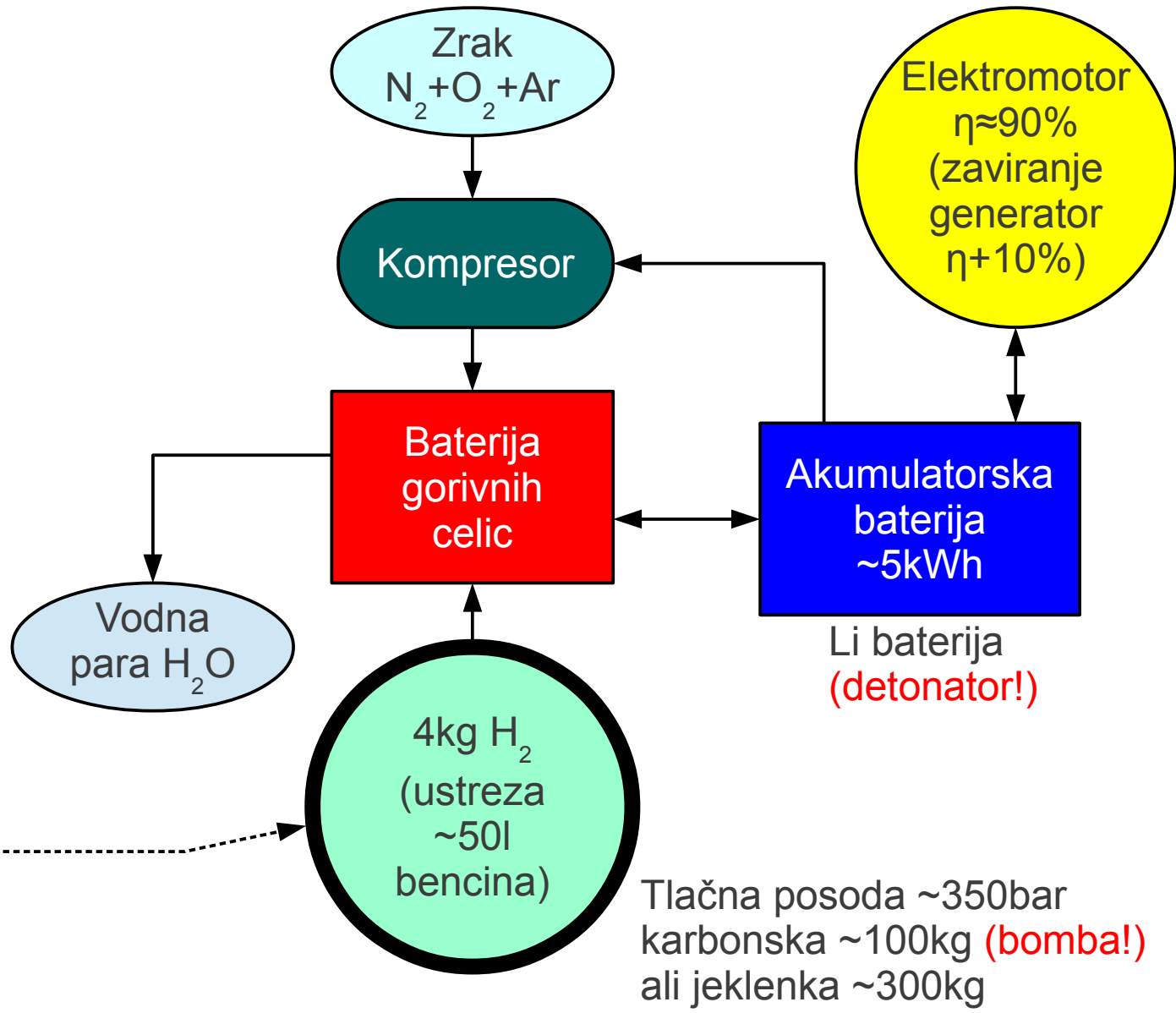

Tlačna posoda ~350bar
 karbonska ~100kg (bomba!)
 ali jeklenka ~300kg

Zahteve za avto na akumulatorske baterije:

- Hlajenje elektromotorja (preprostejše od bencinarja)
- Gretje in hlajenje baterije (novo!!!)
- Težko izvedljivo pri predelavi vozila
- Zamenjava baterije ni praktična (hladilna tekočina)
- Nevarnost požara oziroma eksplozije baterije?
- Izvedba vozila: štiri kolesa, tricikel ali drugo?
- Predelava vozila ne omogoča sprememb
- Žal malo uporabnih inovacij
- Položaj težišča vozila?
- Številne ponesrečene in nevarne izvedbe vozil!
- Izvedba pogona vozila?

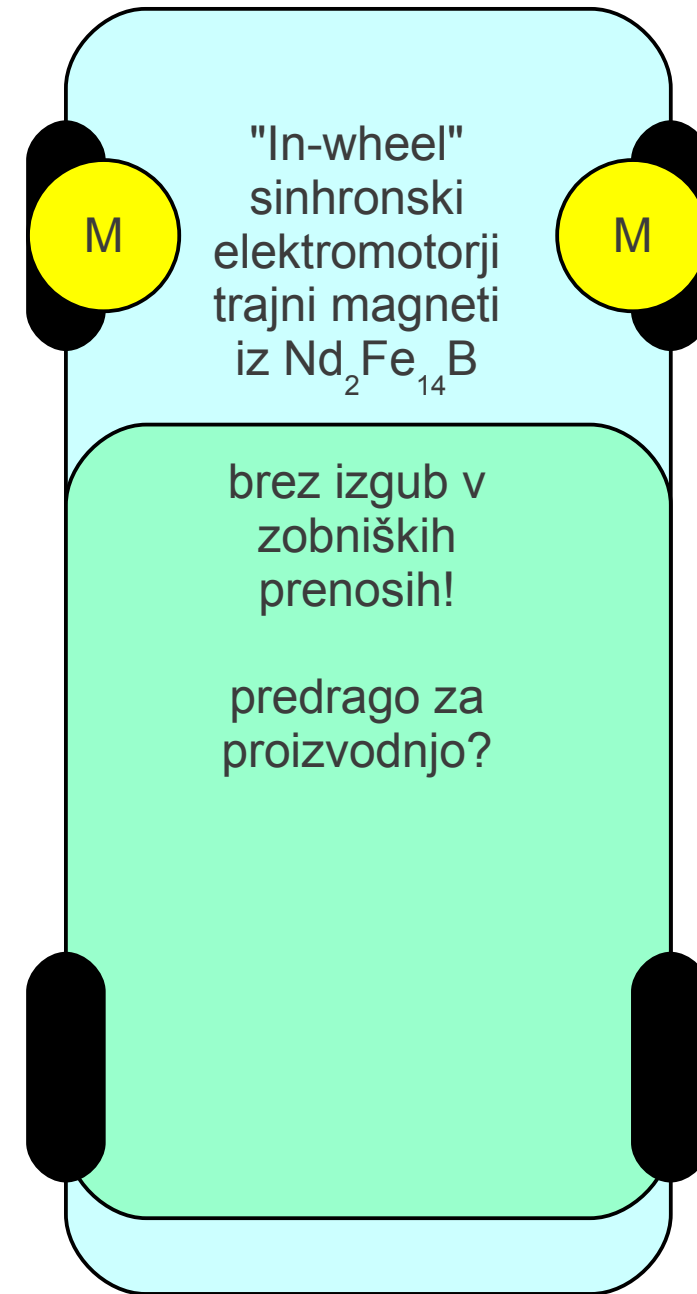
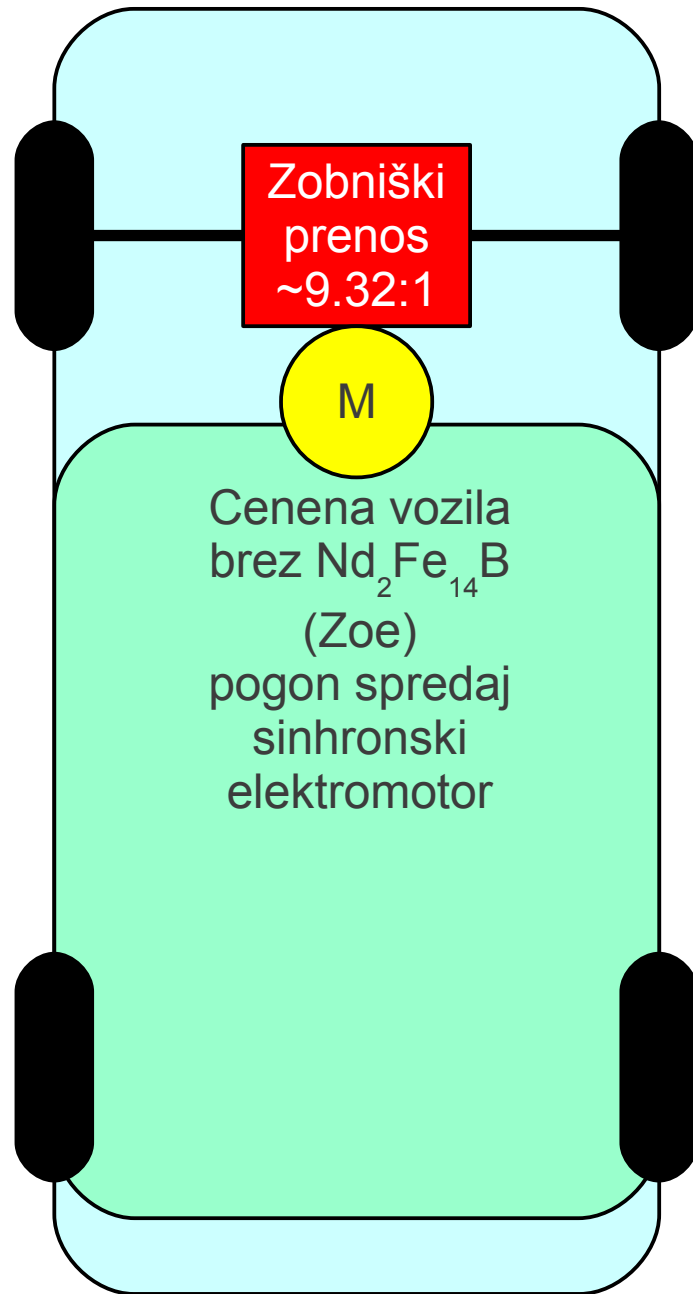
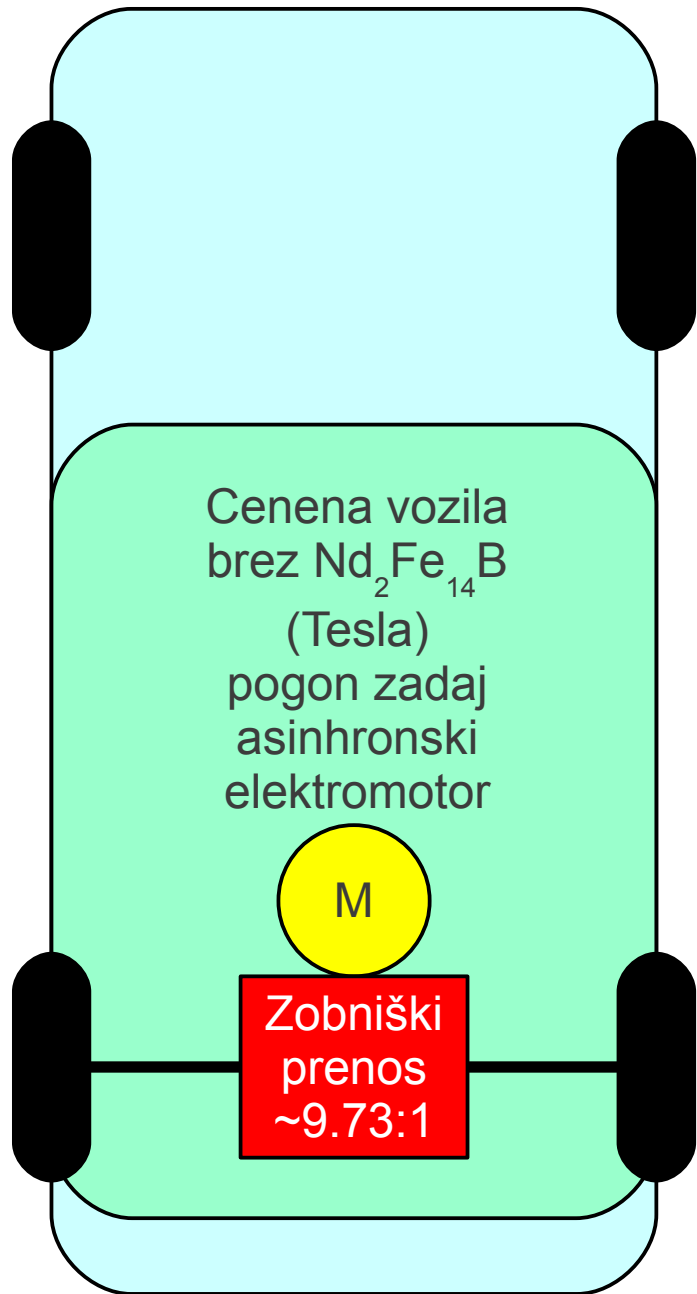

Težišče vozila z baterijo 40kWh \equiv 300kg
(ustreza \sim 15l bencina)

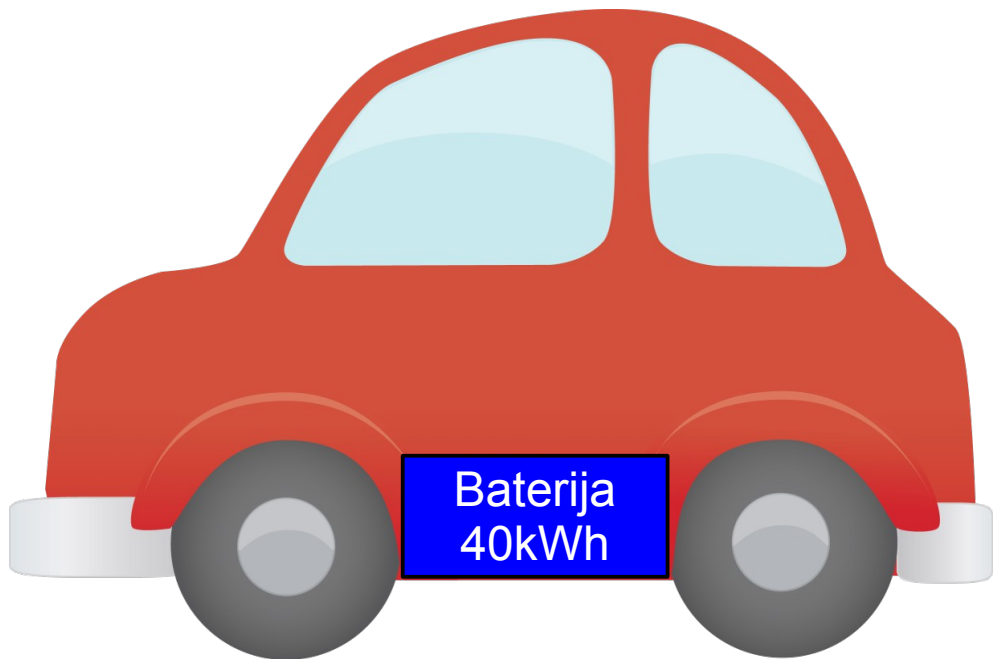

Nizko težišče v sredini \equiv
upravljivo in varno vozilo
(primeri: Tesla, Zoe)

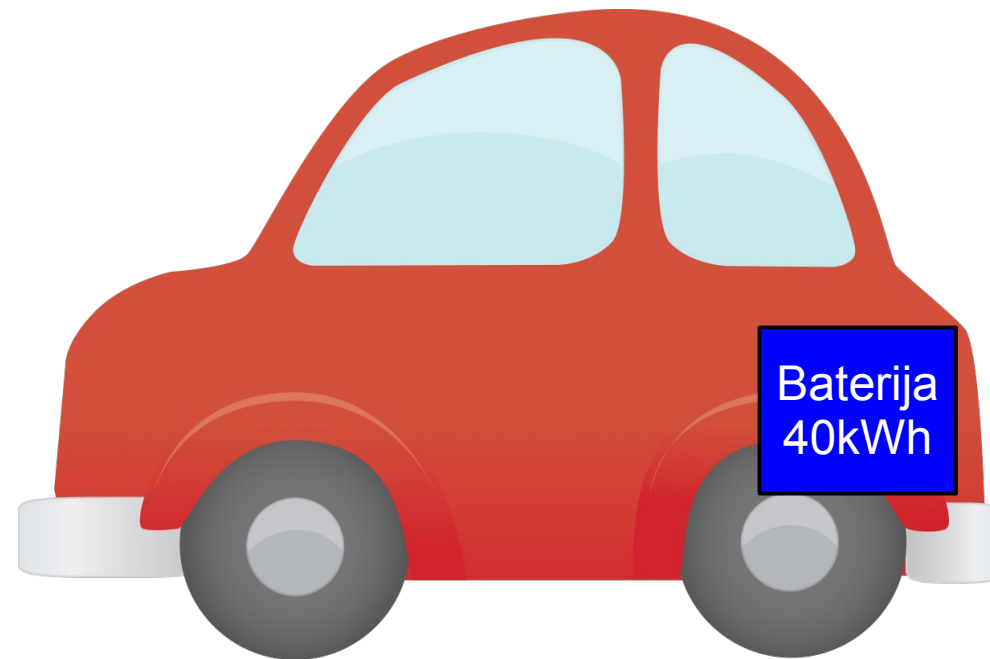

Visoko težišče zadaj \equiv
nevarno in slabo upravljivo
(predelana vozila, E-golf)

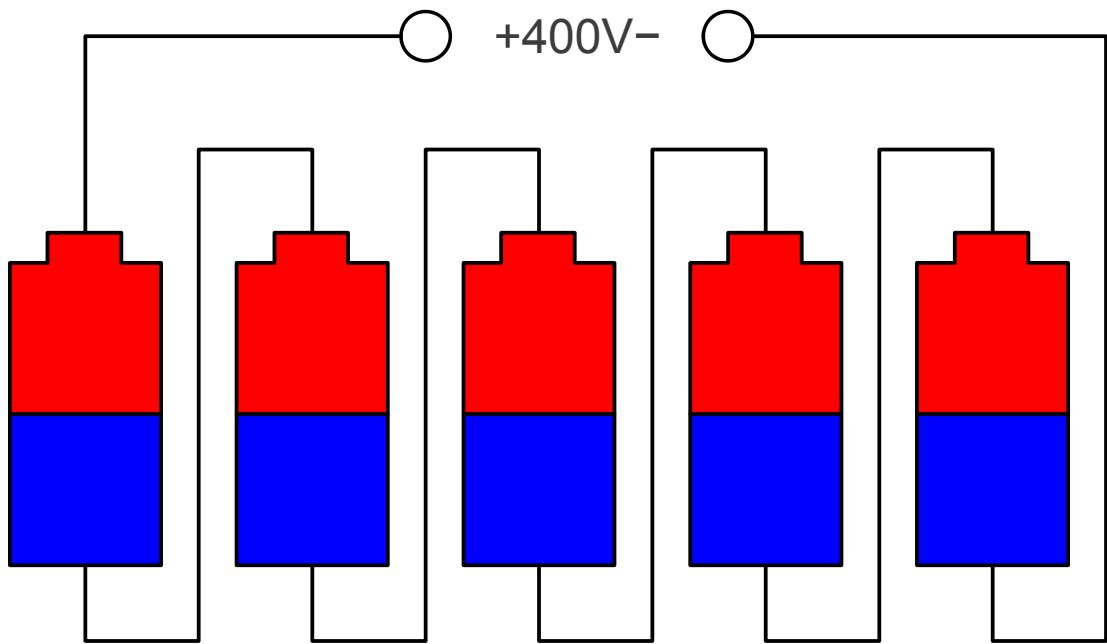

cca 100 popolnoma enakih celic

Idealna baterija
električnega vozila

Resnična baterija
električnega vozila

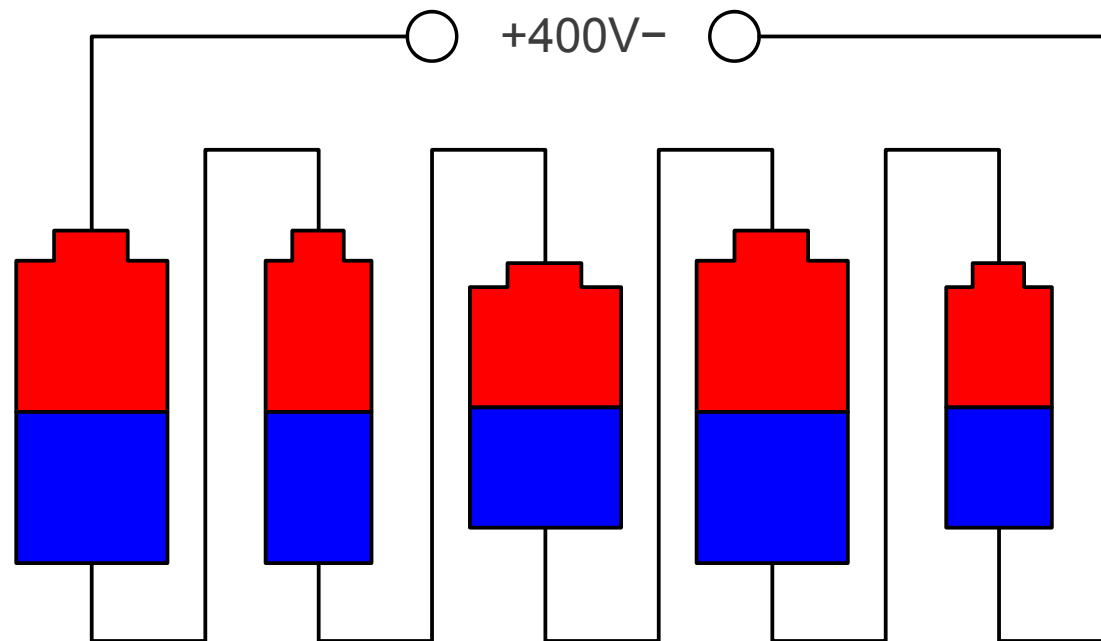

cca 100 med sabo različnih celic

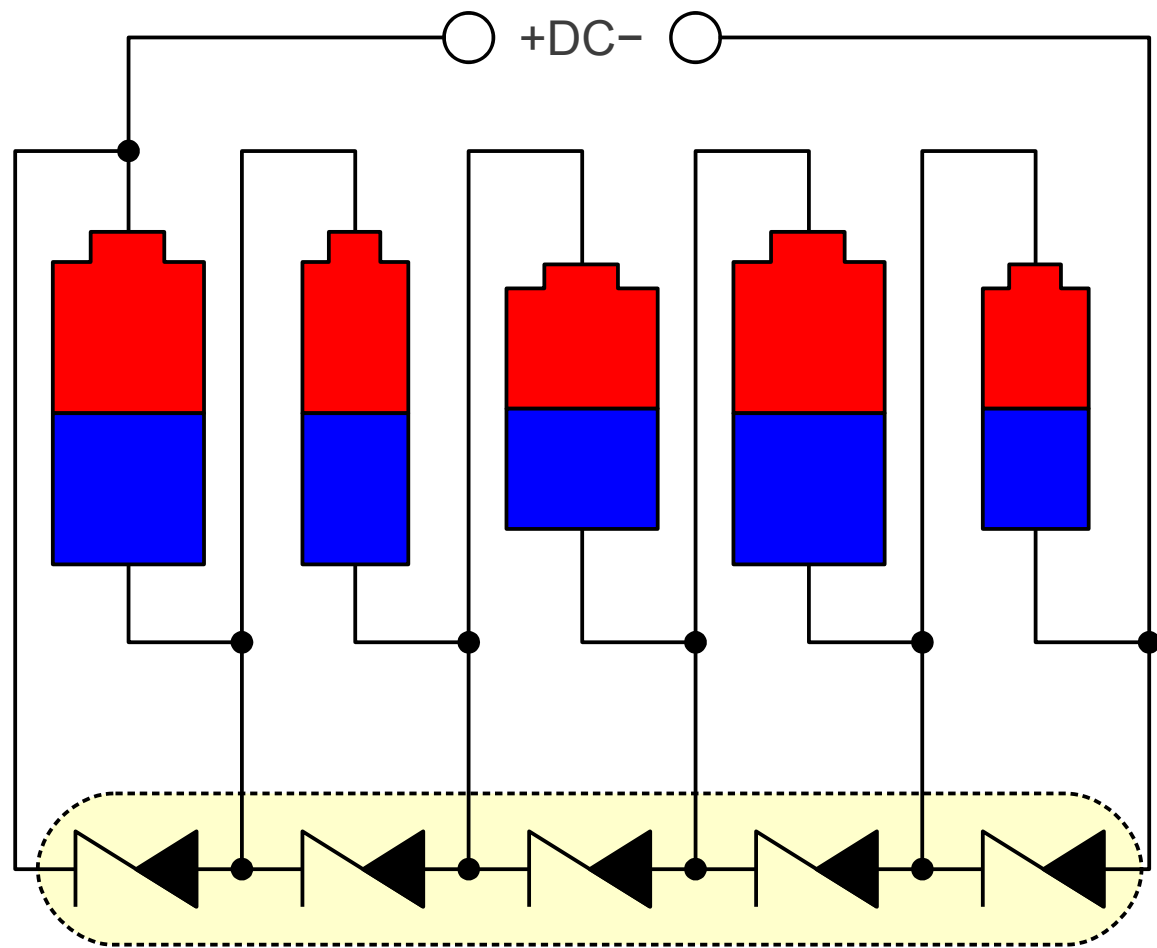

Preprost uravnoveževalec deluje samo pri polnjenju baterije do 100%

Celovit uravnoveževalec deluje med polnjenjem in praznjenjem

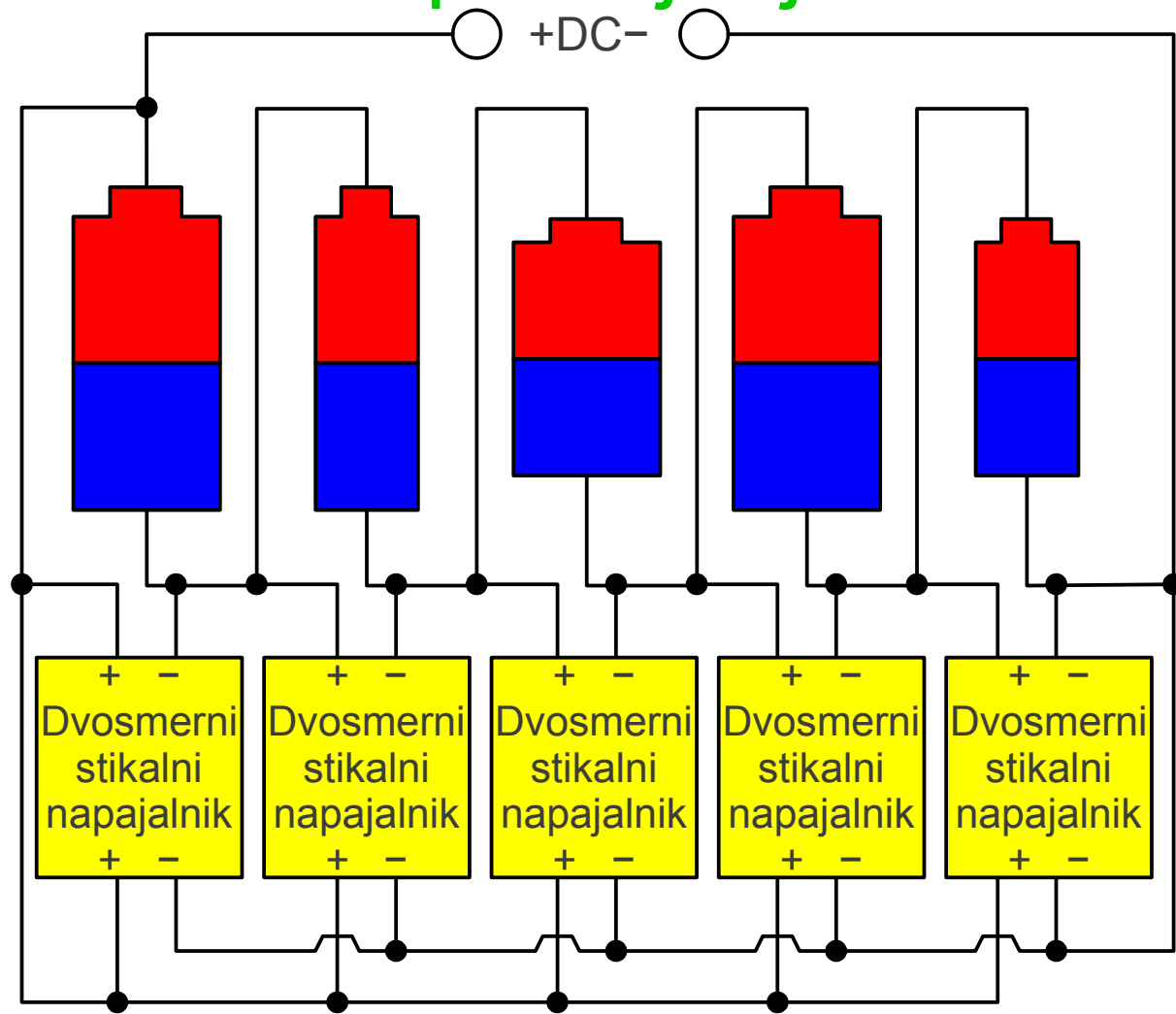

Več javnih polnilnic kot električnih avtov?



Neenoten dostop
Slabo vzdrževane
Nepraktična uporaba
Neprimerne za
obstoječe baterije

Vehicle-To-Grid?

Cena pretočene energije \approx
 \approx 20% cene
nove baterije!

Organizirana
izraba starih
baterij
30%...70%
zmožljivosti

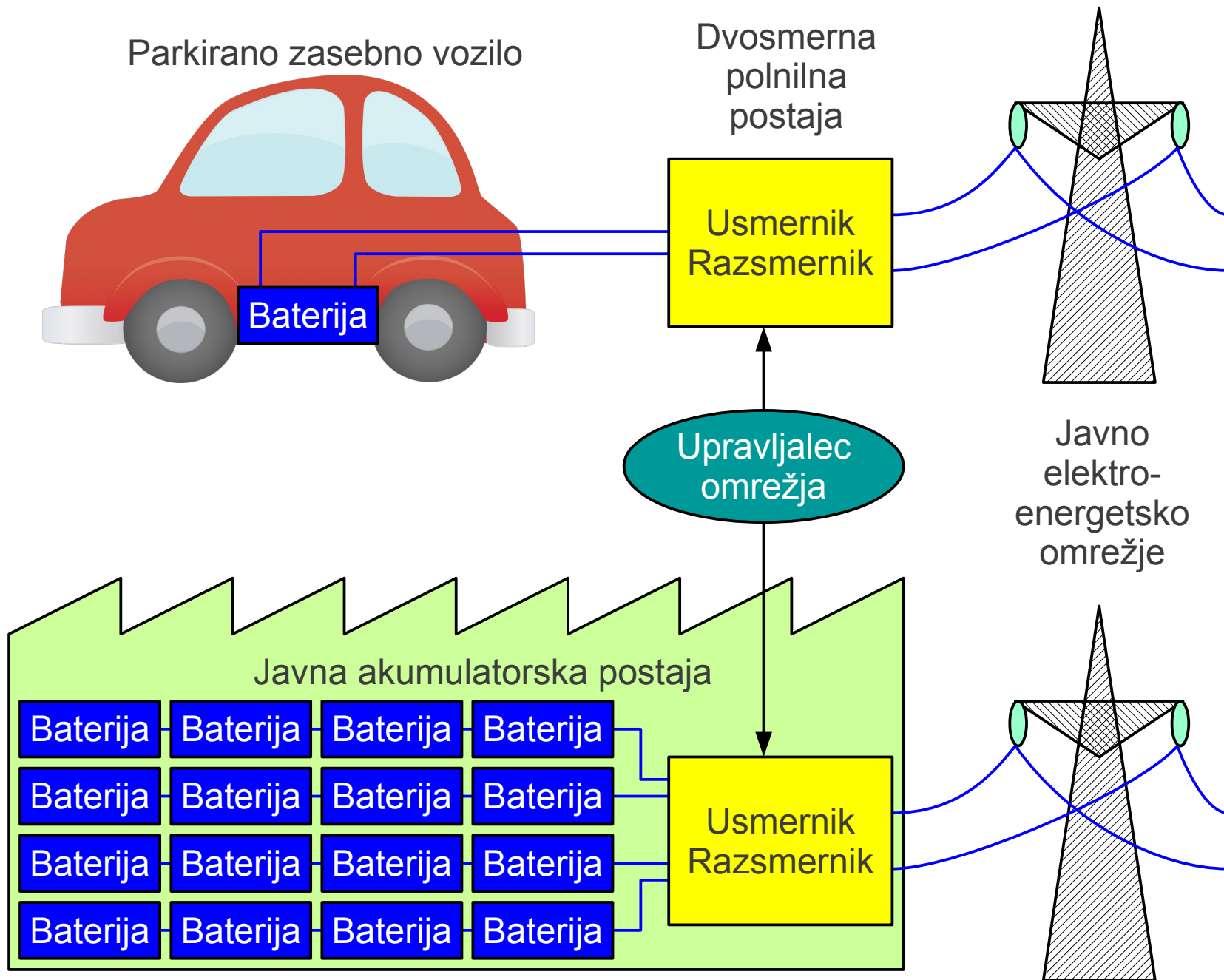

Ljubljana FE - enofazna vtičnica 16A
+ kabel Renault ZE (omejen 8A) ~24h



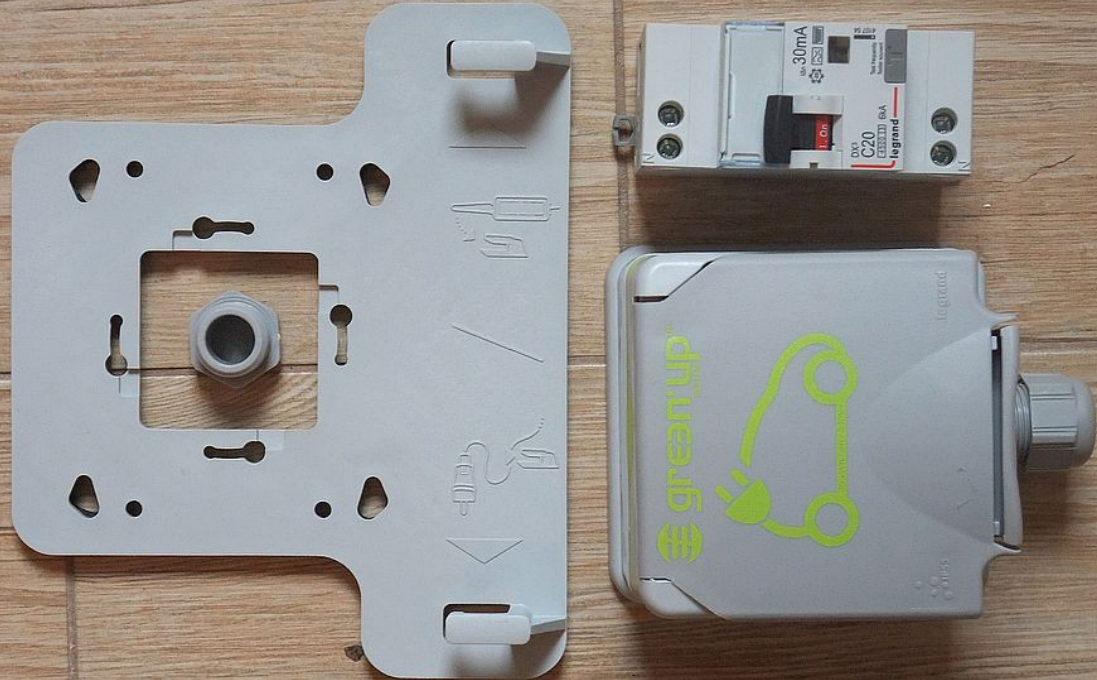

Enofazna šuko vtičnica
Legrand "GreenUp"
posrebreni kontakti 14A
vsebuje RFID tag, ki
deluje samo s kablom
Renault ZE (12A) ~16h



vikend
Ajdovščina



A white electric car is parked at a charging station. The car is connected to a charging cable that is plugged into a charging port on the front of the car. The charging station is a grey, rectangular unit mounted on a concrete pillar. A green light is visible on the charging station, indicating that the car is charging. The car is parked on a paved area with yellow markings. In the background, there is a grassy field and some buildings.

Ljubljana FRI - trifazna
polnilna postaja 3x32A ~2h

Maribor FER1 - trifazna vtičnica 3x16A ~4h





Nova Gorica (doma)
trifazni podaljšek 3x16A
+ kabel Juice Booster 2 ~4h

Ljubljana FE - enofazna vtičnica 16A
+ shekan Juice Booster 2 (16A) ~12h



Ljubljana FE - nova trifazna
polnilna postaja 3x32A ~2h



Izmenična okvara

FID 30mA~

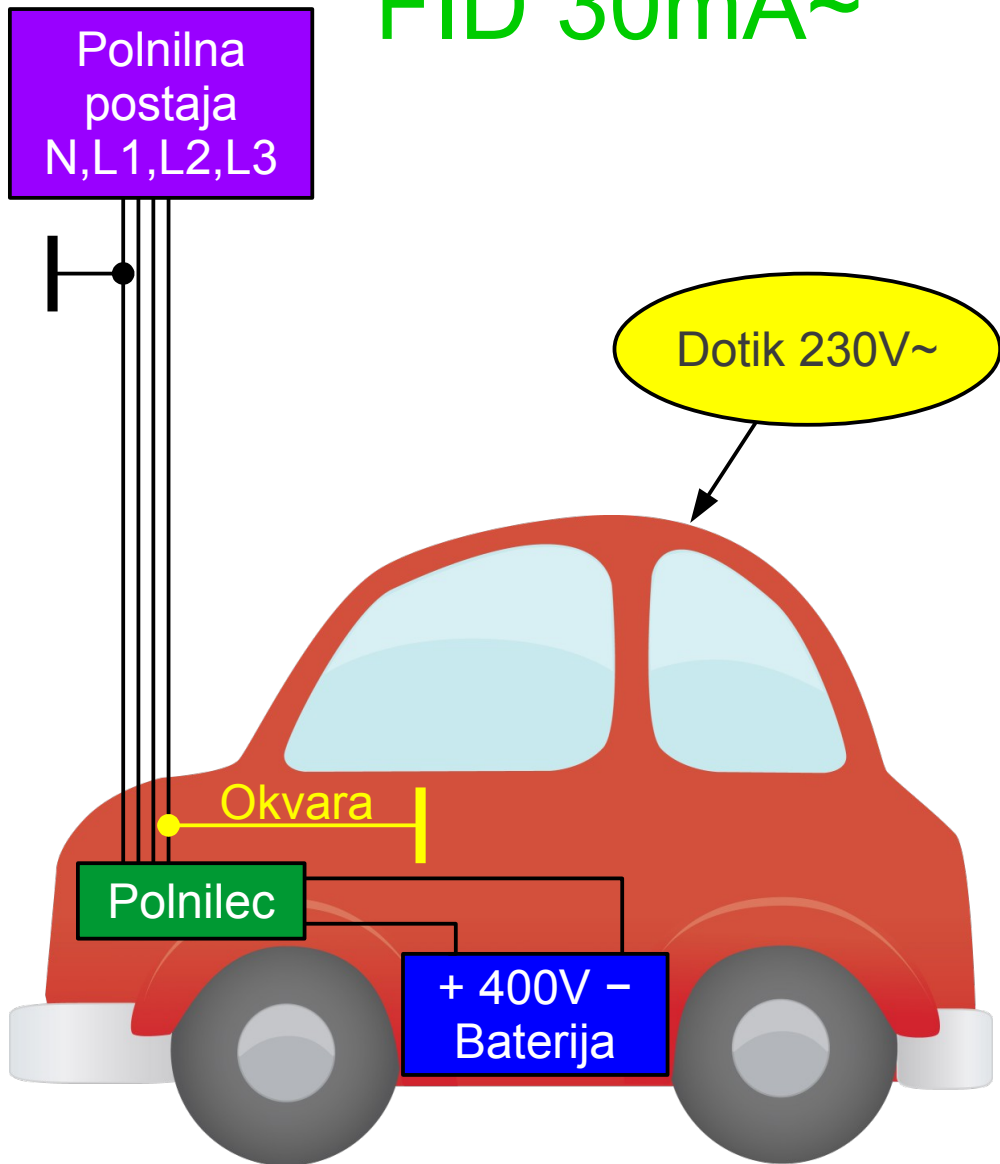

Enosmerna okvara

FID 6mA=
~300eur!

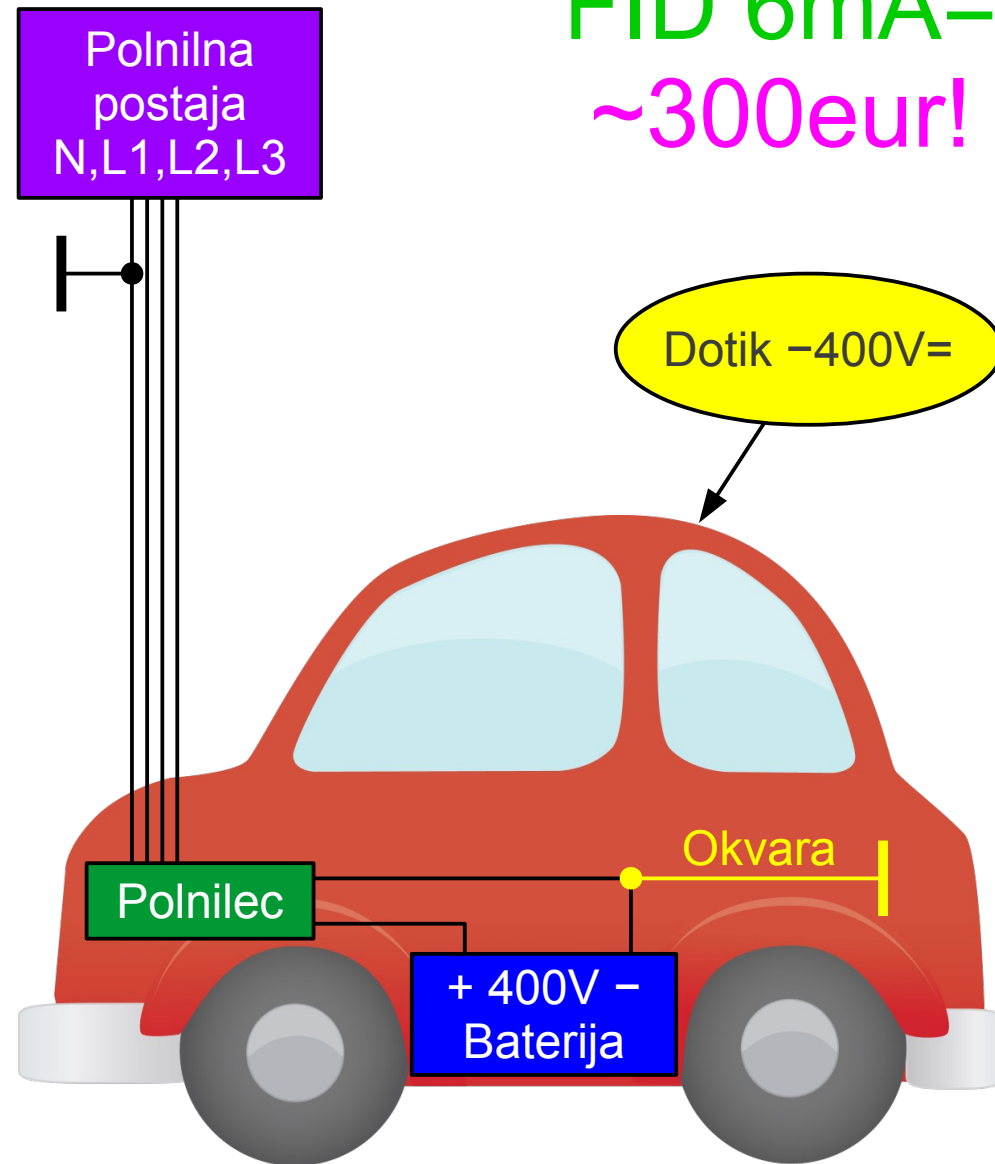



Stari
3x16A
"šuko"
nevaren!

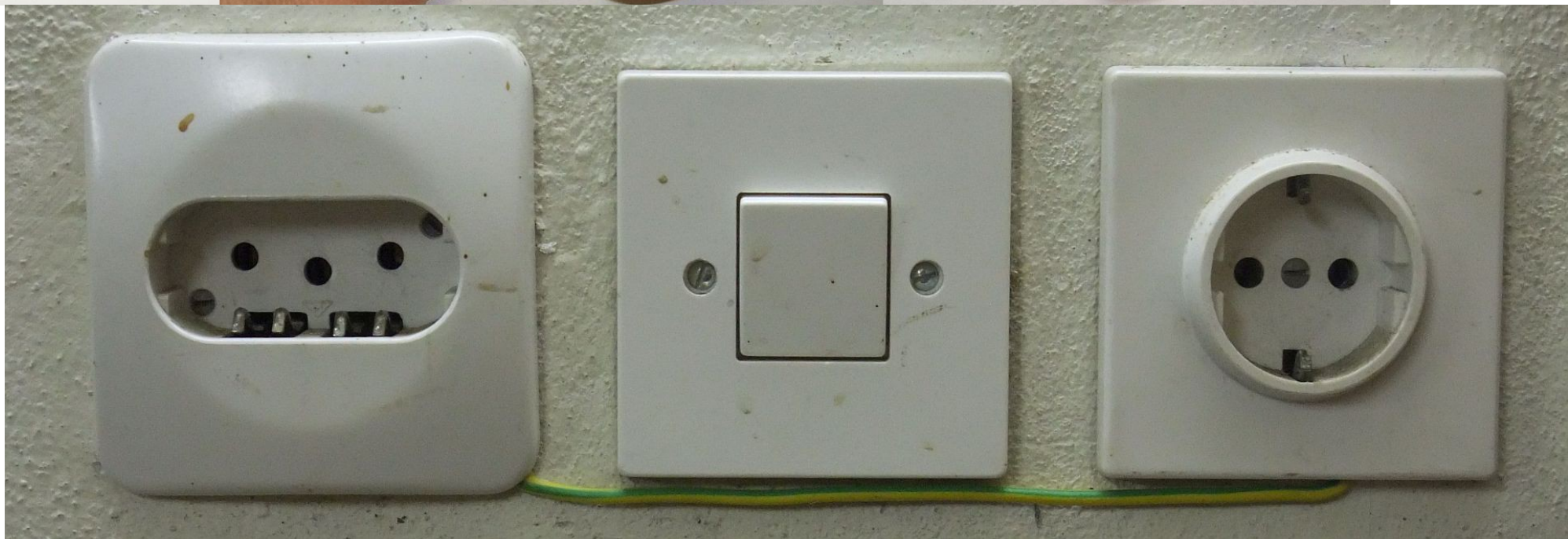

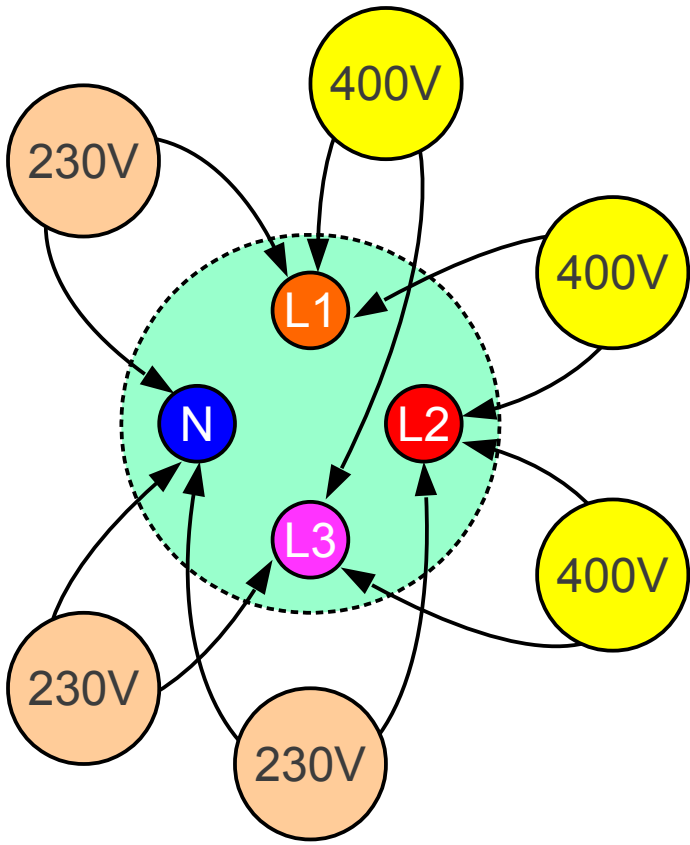

**Avtomobilaska
vezava**

Kmetijska vezava

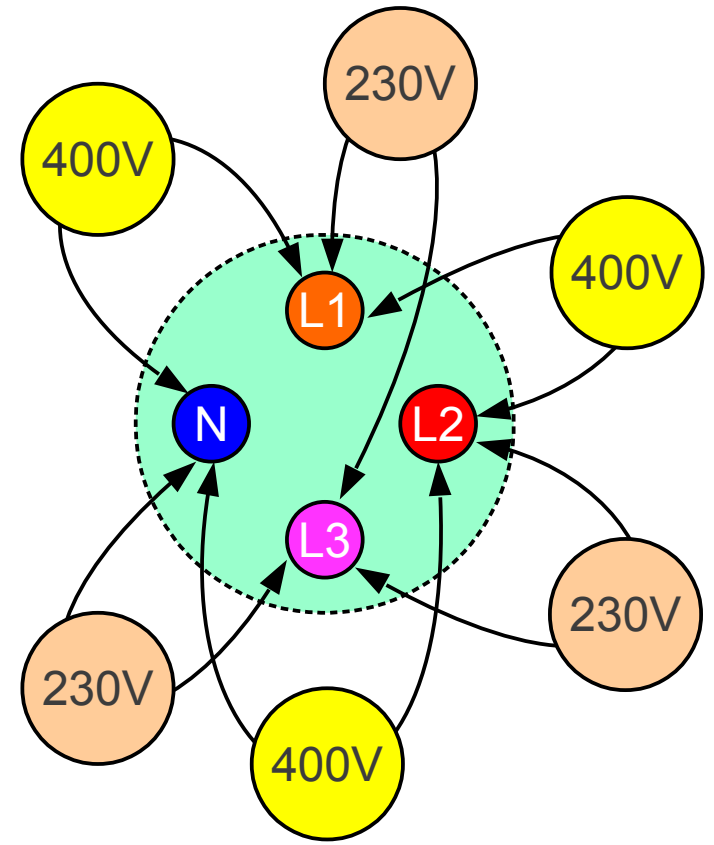
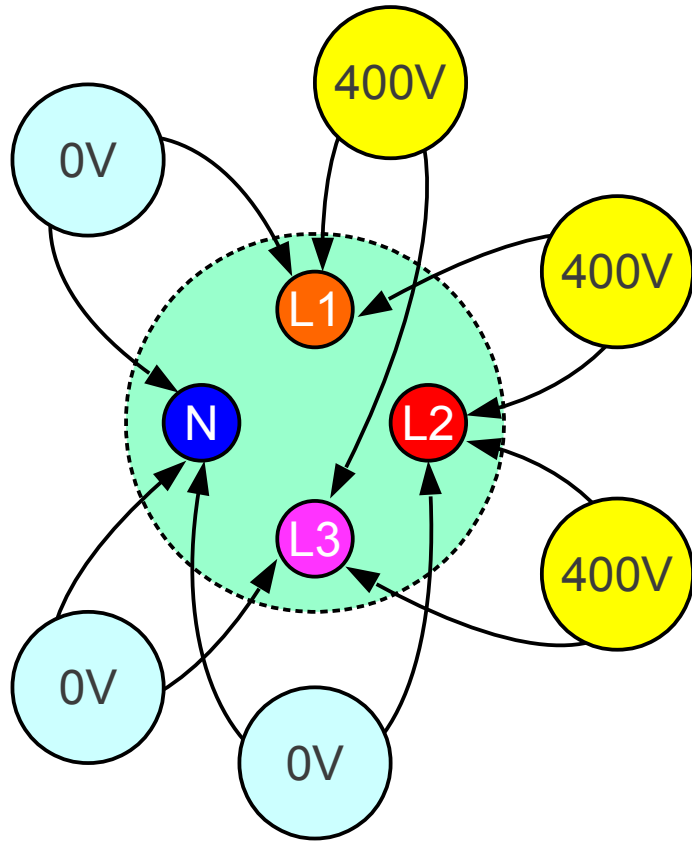

**Električarska
vezava**

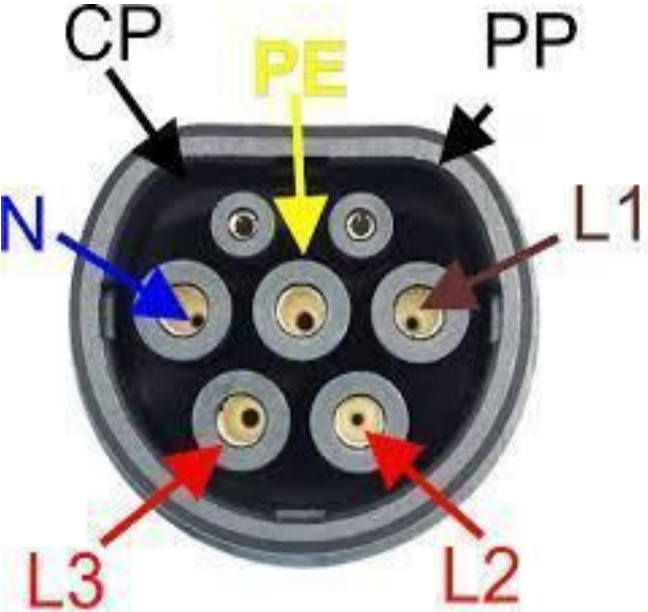

Type 2 Female Plug Pinout

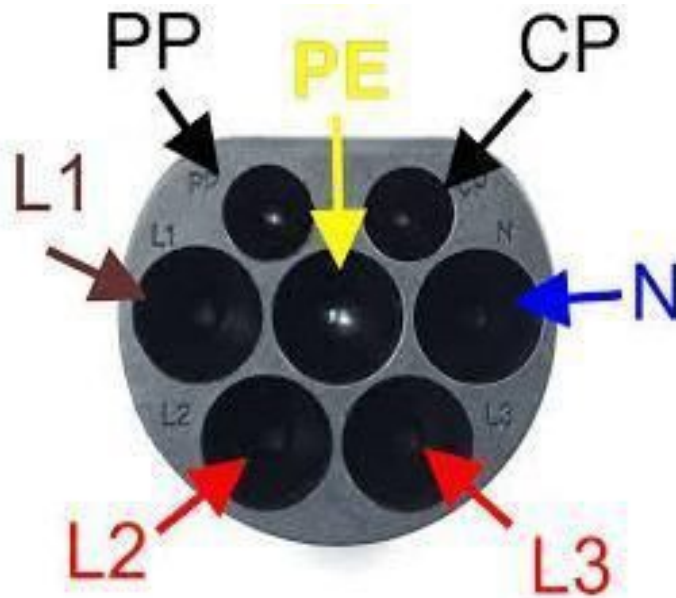

Type 2 Male Plug Pinout

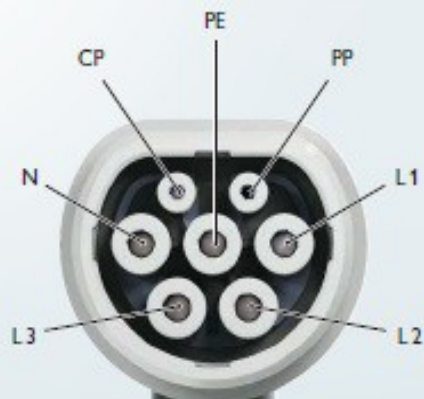

AC vehicle connector Type 2

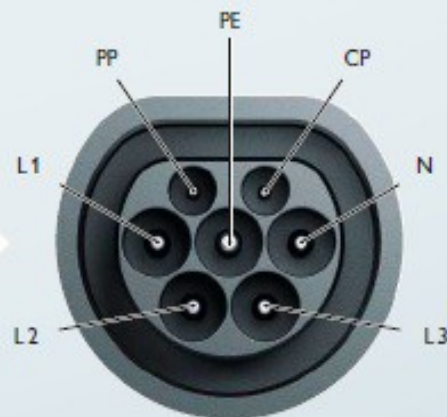

AC vehicle inlet Type 2

	<p>AC ein - bis dreiphasig</p>	<p>max. 500V AC 3 x 63A oder 1 x 80A</p>
	<p>AC ein - bis dreiphasig DC-Low</p>	<p>max. 500V AC/DC 3 x 63A AC oder 1 x 70A AC oder 1 x 80A DC</p>
	<p>DC-Mid</p>	<p>max. 500V DC 1 x 140 A</p>
	<p>DC-High</p>	<p>≥ 500V DC 1 x 200A</p>

EN 61851

FID zaščita (RCD) 30mA~ & 6mA=

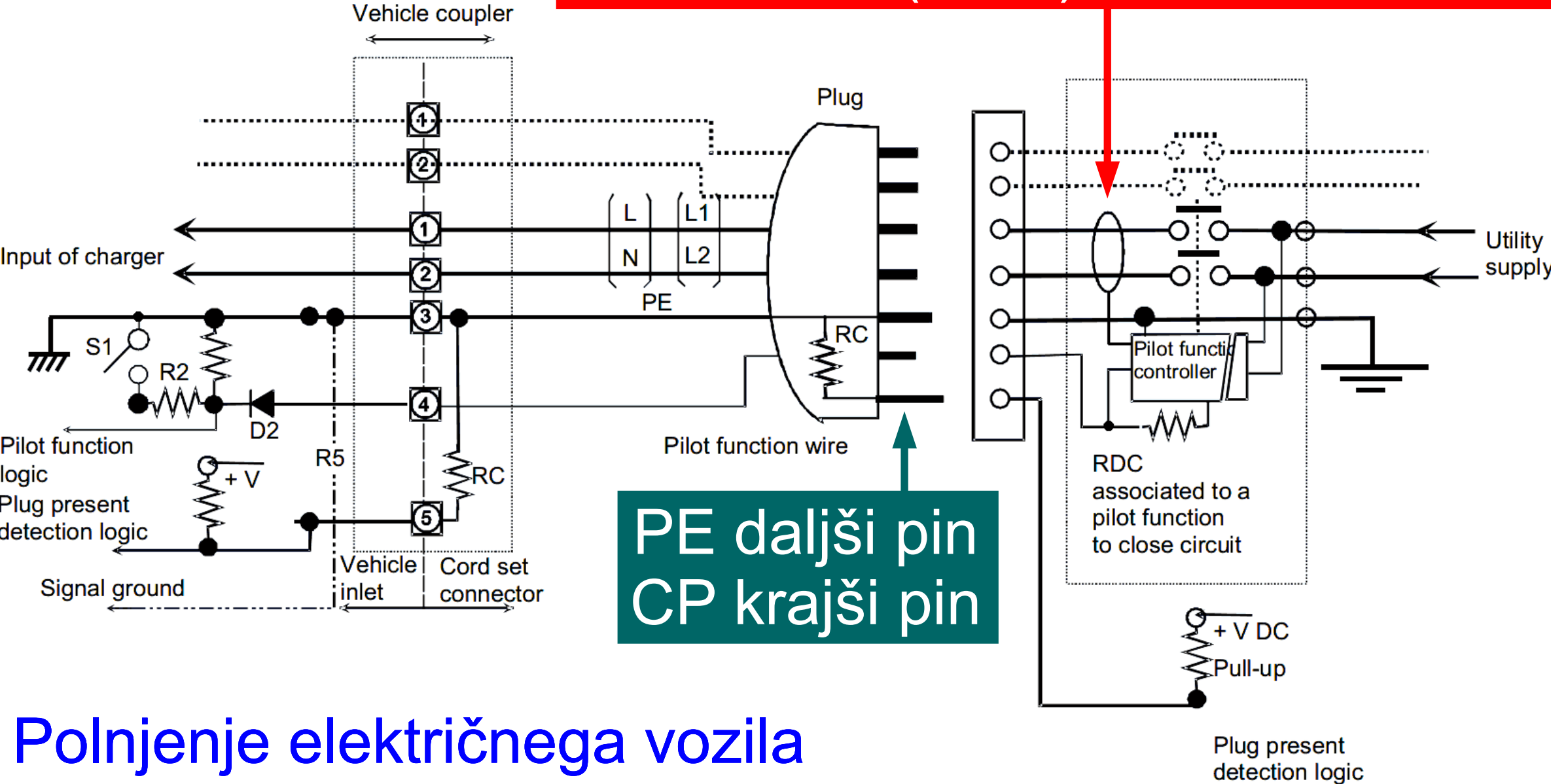

PE daljši pin
CP krajši pin

Polnjenje električnega vozila

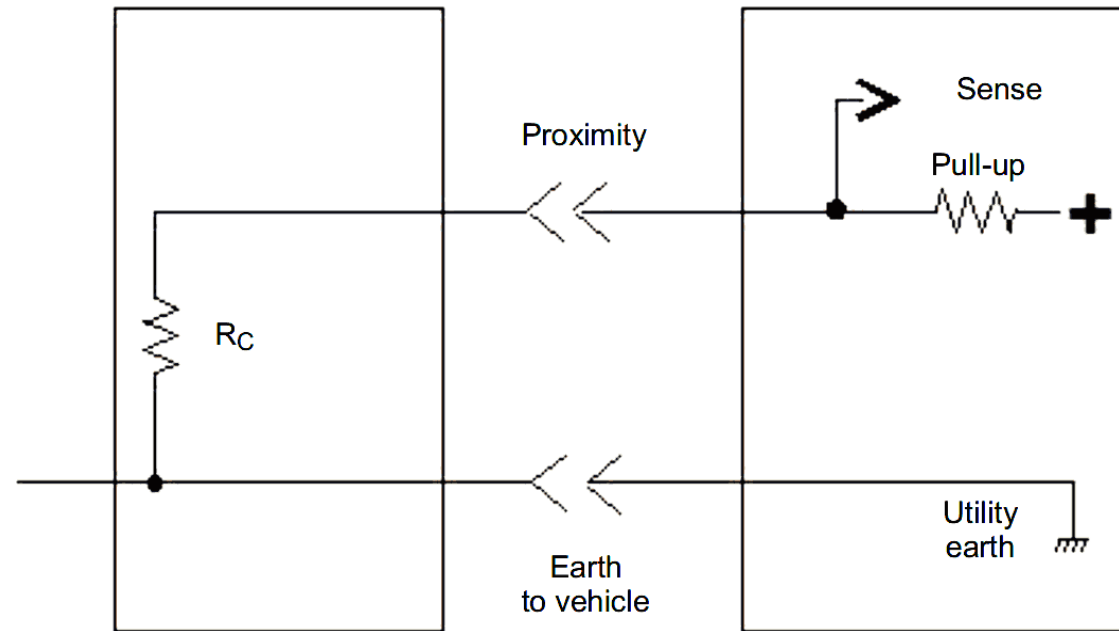

Vezava signala Proximity Pilot (PP)

Current capability of the cable assembly	Equivalent resistance of R _c Tolerance $\pm 3\%$ ^c
13 A	1,5 k Ω 0,5 W ^{a, b}
20 A	680 Ω 0,5 W ^{a, b}
32 A	220 Ω 0,5 W ^{a, b}
63 A (3 phase) / 70 A (1 phase)	100 Ω 0,5 W ^{a, b}

^a The power dissipation of the resistor caused by the detection circuit shall not exceed the value given above. The value of the pull-up resistor shall be chosen accordingly.

^b Resistors used should preferably fail open circuit failure mode. Metal film resistors commonly show acceptable properties for this application.

^c Tolerances to be maintained over the full useful life and under environmental conditions as specified by the manufacturer.

EN 61851 (povzeto po SAE J1772)

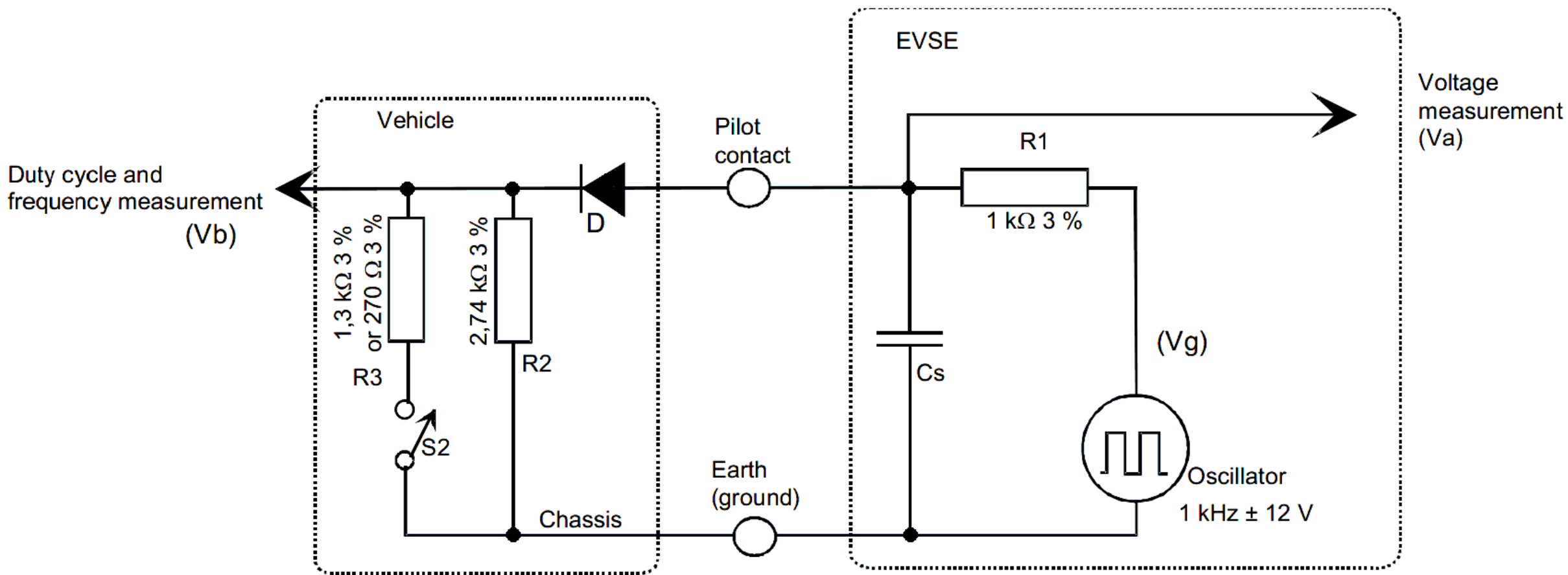

Vezava signala Control Pilot (CP)

Vehicle state	Vehicle connected	S2	Charging possible	Va ^a	
A	no	open	no	12 V ^d	Vb = 0 V
B	yes	open	no	9 V ^b	R2 detected
C	yes	closed	Vehicle ready	6 V ^c	R3 = 1,3 kΩ ± 3 % Charging area ventilation not required
D				3 V ^c	R3 = 270 Ω ± 3 % Charging area ventilation required
E	yes	open	no	0 V	Vb = 0: EVSE, utility problem or utility power not available, pilot short to earth ...
F	yes	open	no	-12 V	EVSE not available

^a All voltages are measured after stabilization period, tolerance ±1 V.

^b The EVSE generator may apply a steady state DC voltage or a ±12 V square wave during this period. The duty cycle indicates the available current as in Table A.5.

^c The voltage measured is function of the value of R3 in Figure A.1 (indicated as Re in Figure A.2).

^d 12 V static voltage.

Protokol polnjenja Control Pilot (CP)

EN 61851

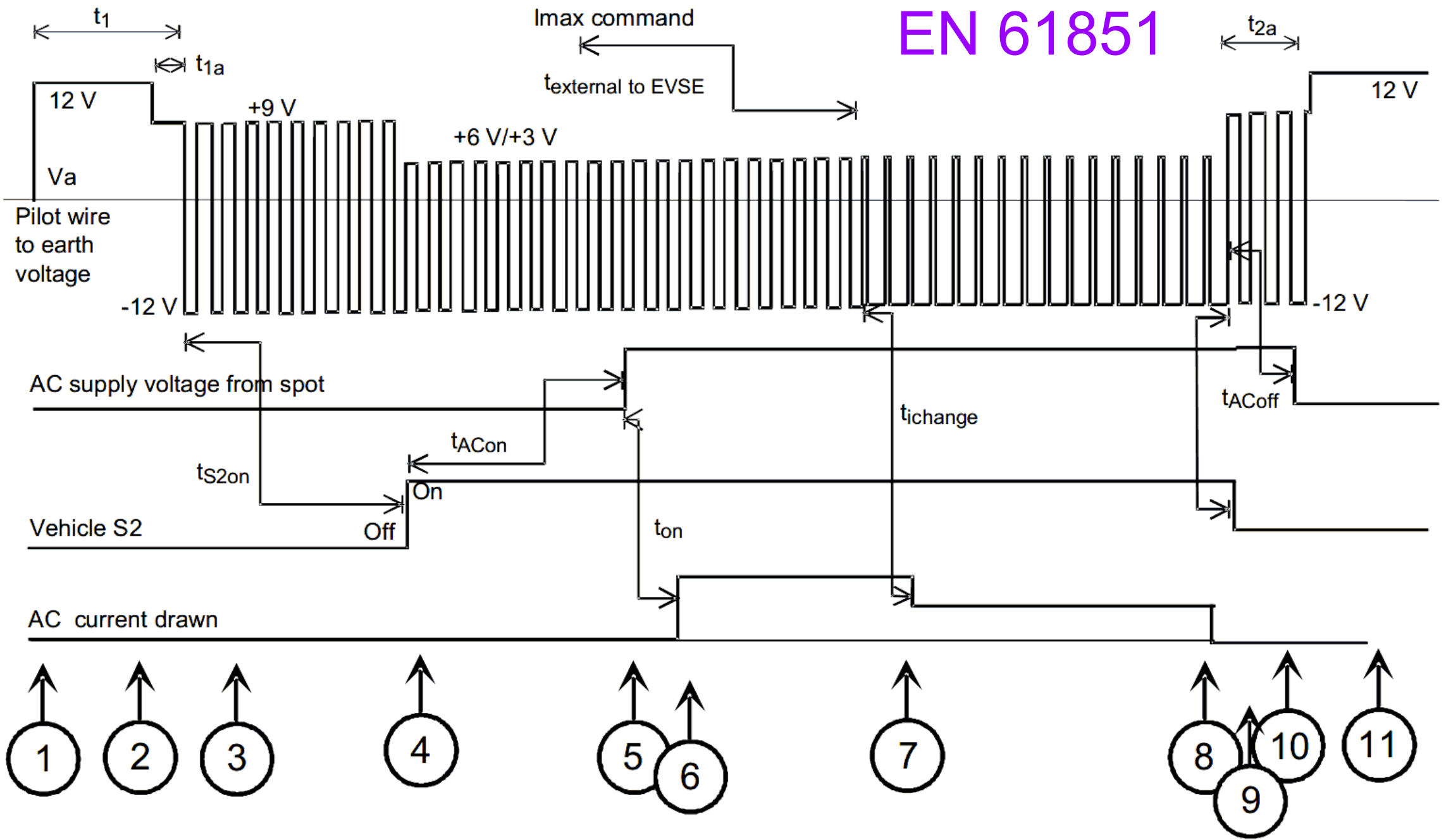

Nominal duty cycle interpretation by vehicle	Maximum current to be drawn by vehicle EN 61851
Duty cycle < 3 %	Charging not allowed
<p data-bbox="57 293 524 337">3 % ≤ duty cycle ≤ 7 %</p> <p data-bbox="105 444 809 568">Se ne uporablja</p>	<p data-bbox="980 293 2330 474">Indicates that digital communication will be used to control an off-board DC charger or communicate available line current for an on-board charger. Digital communication may also be used with other duty cycles.</p> <p data-bbox="980 515 2085 557">Charging is not allowed without digital communication.</p> <p data-bbox="980 598 2277 680">5 % duty cycle shall be used if the pilot function wire is used for digital communication</p>
7 % < duty cycle < 8 %	Charging not allowed
8 % ≤ duty cycle < 10 %	6 A
10 % ≤ duty cycle ≤ 85 %	Available current = (% duty cycle) × 0,6 A
85 % < duty cycle ≤ 96 %	Available current = (% duty cycle - 64) × 2,5 A
96 % < duty cycle ≤ 97 %	80 A
Duty cycle > 97 %	charging not allowed
<p data-bbox="57 1240 2302 1322">If the PWM signal is between 8 % and 97 %, the maximum current may not exceed the values indicated by the PWM even if the digital signal indicates a higher current.</p>	

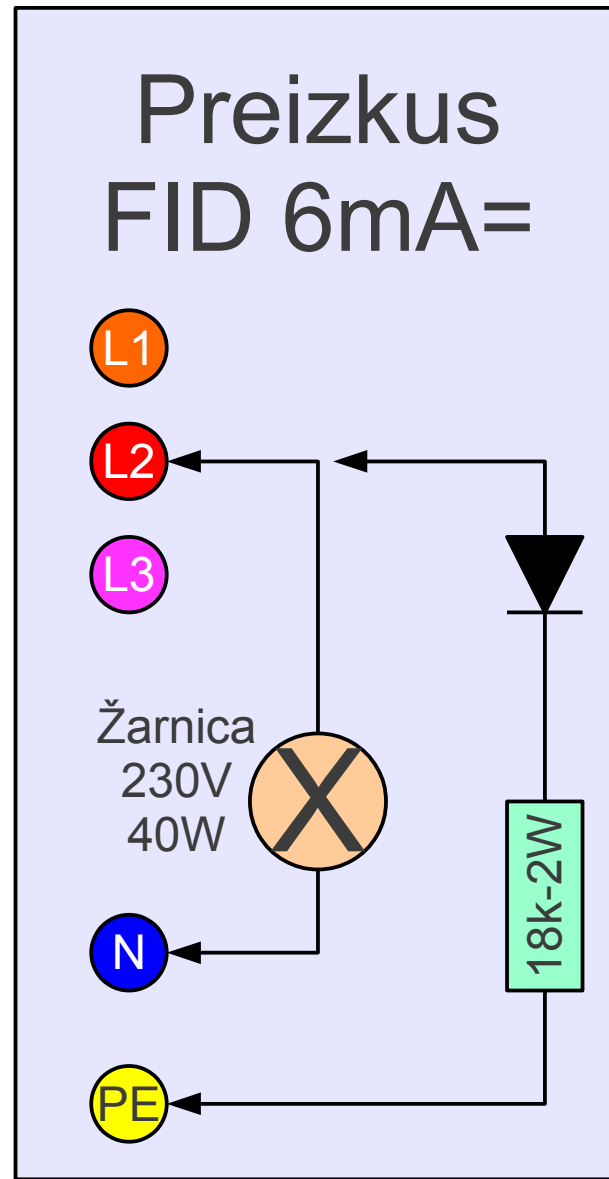
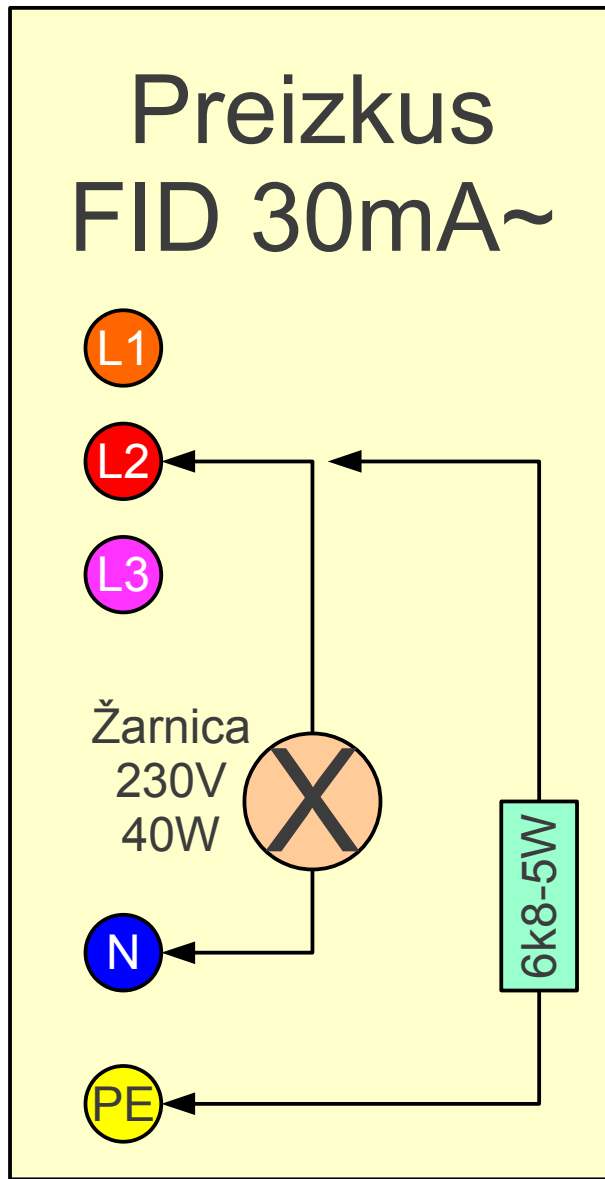
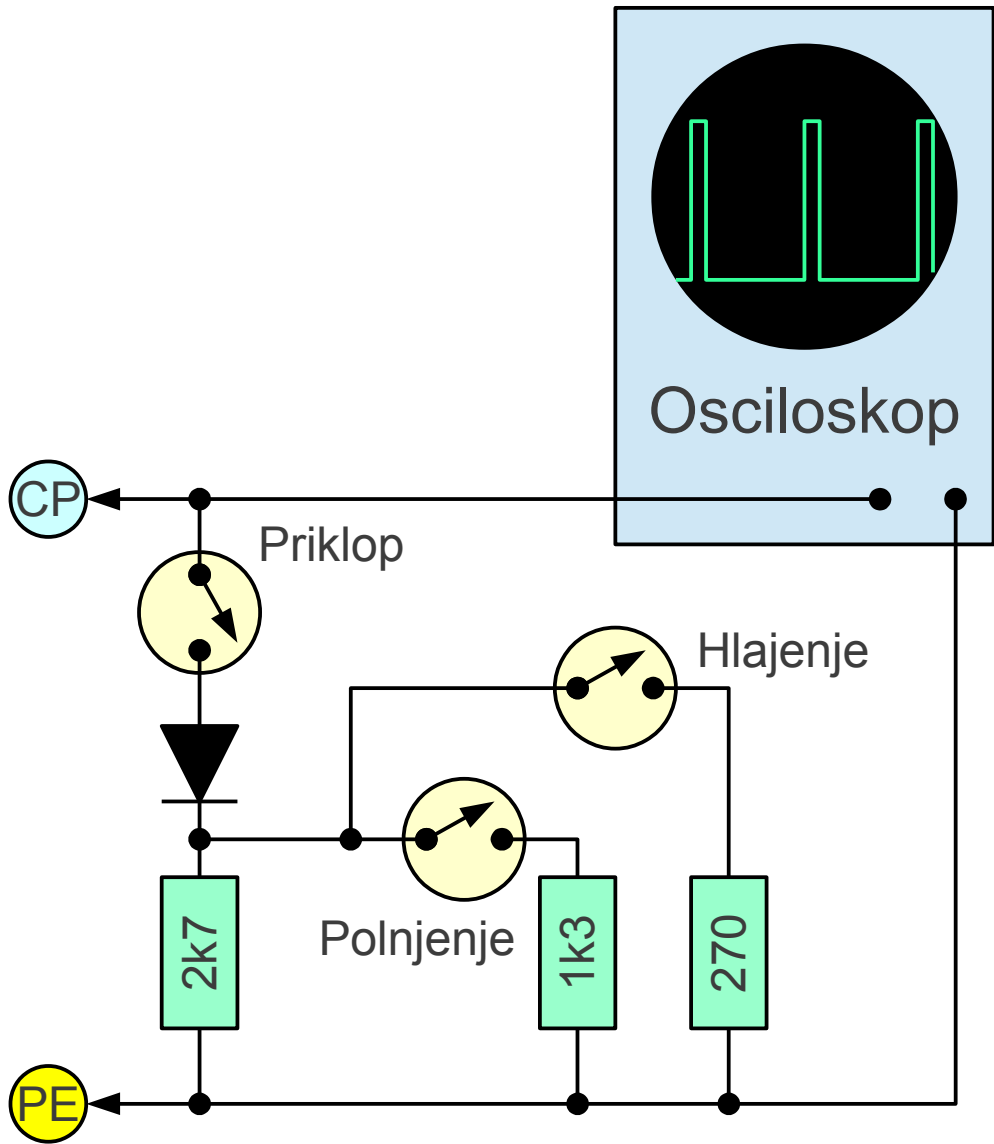

Preizkusna vezja za polnilni kabel ali polnilno postajo

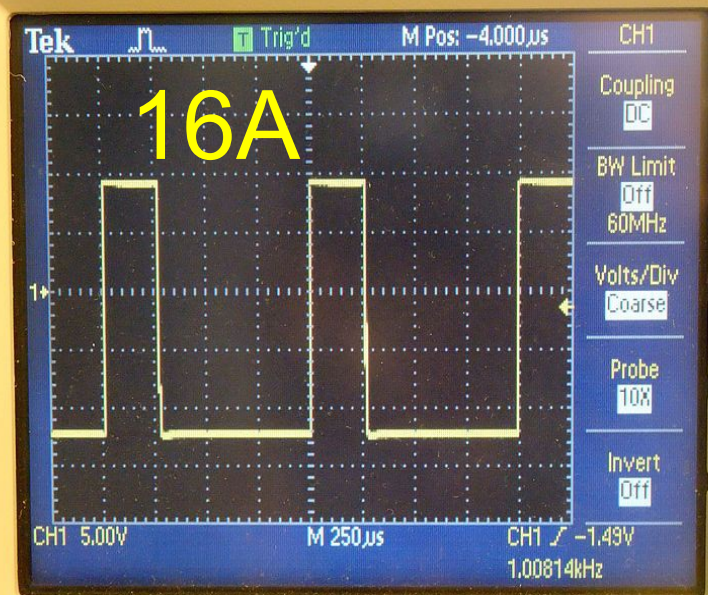
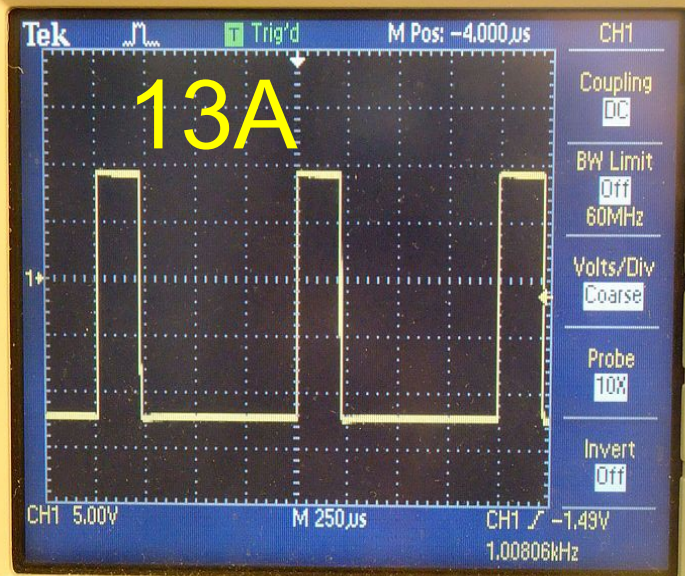
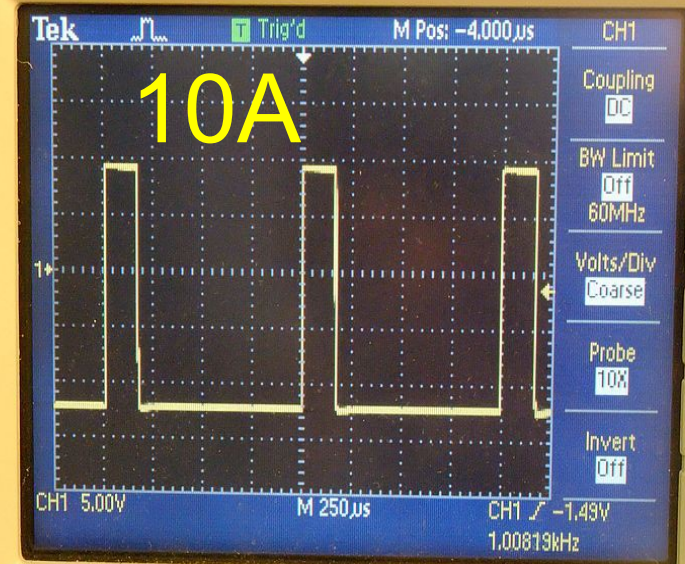
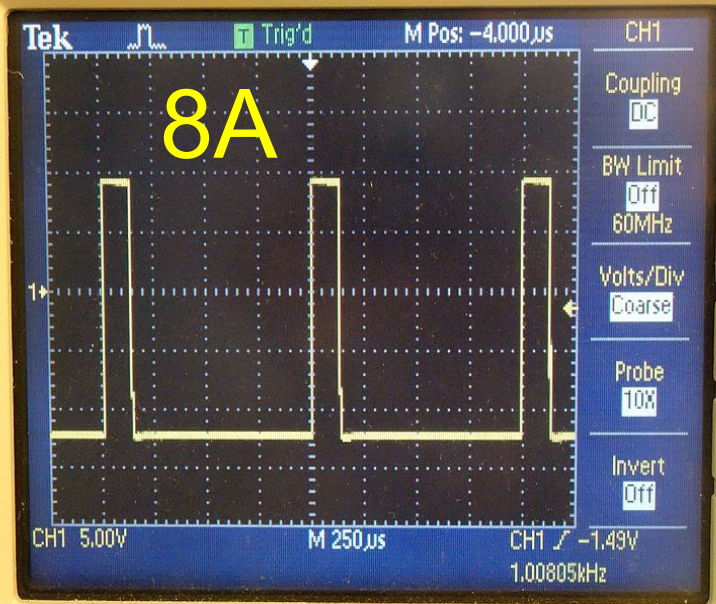
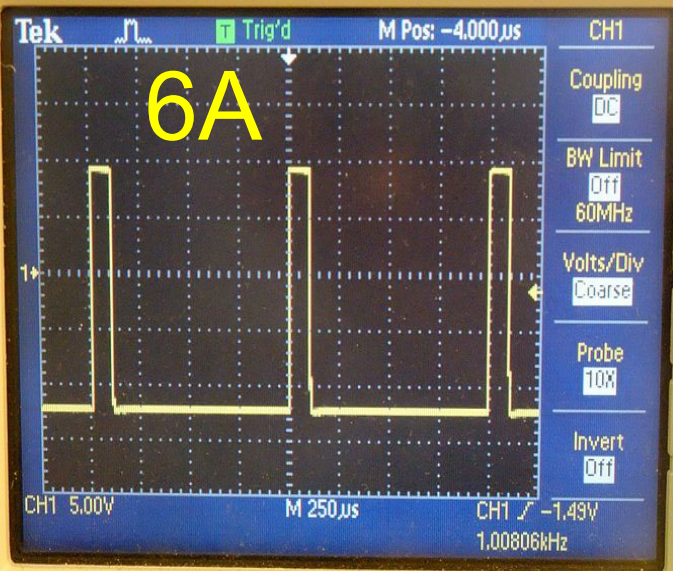

Preizkus kabla
Renault ZE
enofazno 10A/14A

Oklešččen
protokol
EN 61851

Nima FID (RCD) 6mA=

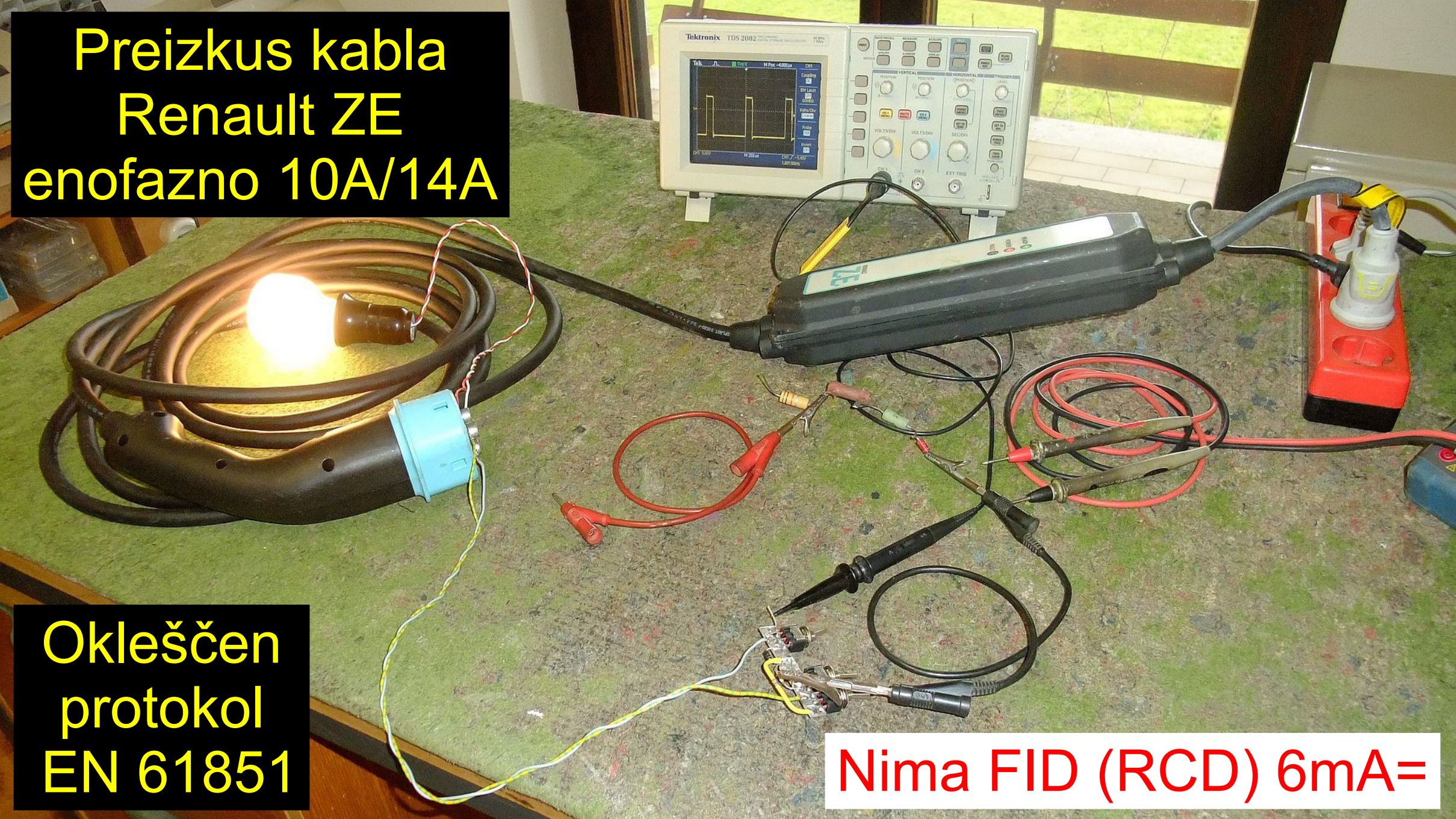

Preizkus kabla Juice Booster 2



Nastavljiv tok
6A...32A 1..3faze



Popolnoma
izpolnjuje
EN 61851





Nova polnilnica FE – 3x32A

Okleščen protokol EN 61851

Nima FID (RCD) 6mA=

Nima tipke za RESET FID

Ne zaklepa vtikača Mennekes

Nastavitev toka ni možna

Zračni upor $F_{upor} = \alpha \frac{p v^2}{T}$

$p \equiv$ zračni tlak

$v \equiv$ hitrost vozila

$T \equiv$ absolutna temperatura

Delo $W = (F_{upor} + F_{trenje}) \cdot s$

$s \equiv$ prevožena pot [km]

Hitrost	Povprečna poraba
50km/h	8kWh/100km
75km/h	14kWh/100km
100km/h	23kWh/100km
125km/h	34kWh/100km

Domet baterijskega vozila pozimi:
 (1) povečan zračni upor -10%
 (2) višja notranja upornost baterije -15%
 (3) dodatno greetje kabine -10%

Baterija 40kWh	Zima	Poletje
Povprečni domet	200km	300km
Hitrost vožnje Nova Gorica - Maribor	80km/h	105km/h

Renault Zoe
~10⁵ kosov
samo EU

2012

baterija
22kWh

2015 nov
elektromotor

2016 nova
baterija
41kWh

Izvorno načrtovan kot baterijsko vozilo



Samovozeče vozilo čez 10 let?

Napaka: zmrznil zaslon tamagočija
Protiukrep: dolgo tišči tipke, NE uporabljaj navigacije



Napaka: avto ne starta ali baterija se noče polniti
Protiukrep: odpri in zapri voznikova vrata

Napaka: neuravnotežena baterija

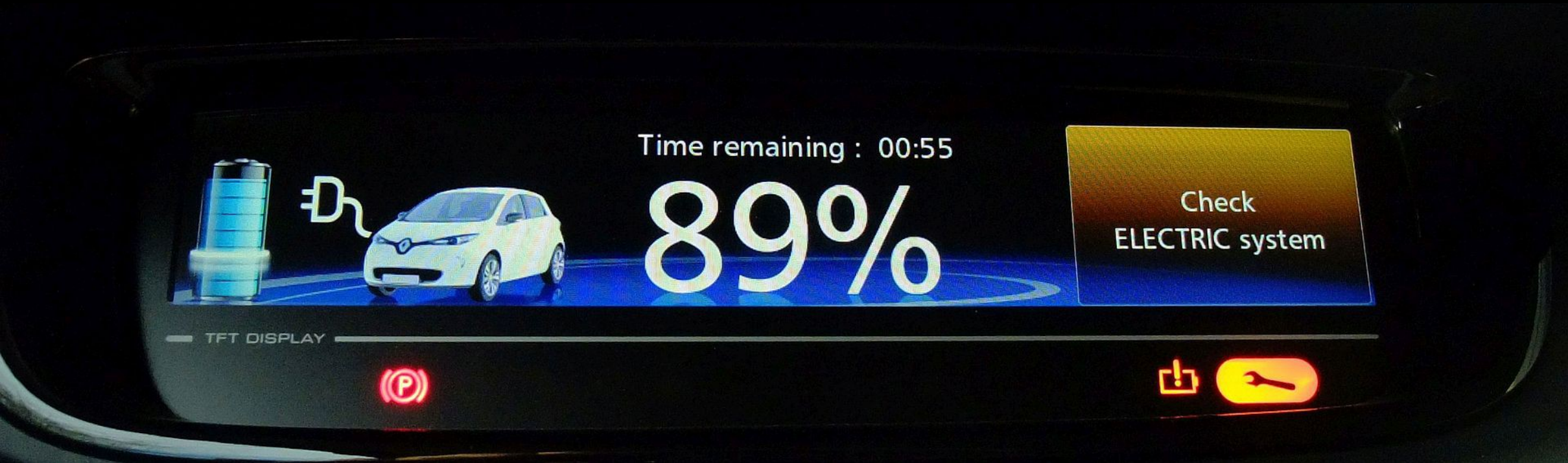

Vzrok: grdo ravnanje z baterijo (nepopolno polnjenje)

Protiukrep: počasno polnjenje baterije do 100%



Natančno
krmiljen
pogon
spredaj
+
nizko težišče
na sredini
=
Renault Zoe
NE potrebuje
zimskih gum
niti verig!

Večina
baterijskih
vozil nima
prtljažnika.

V prtljažnik
Renault Zoe
gresta
brez težav
dve ZIMSKI
potapljaški
opremi!



Stroški Kia Rio
10let (2007–2017):

Nabavna cena vozila
~11keur

Gorivo 31500km
~25keur

Ostalo (zavarovanje,
redni servisi, vinjete)
~10keur

Skupaj ~46keur
11let brez okvar!

Nabavni stroški Renault Zoe:

Stroški vzdrževanja?

Nabavna cena vozila brez baterije ~24keur

Subvencija za novo električno vozilo -7.5keur

Polnilni kabel Juice Booster 2 ~1keur

Skupaj ~17.5keur

Primerjava potovanja Nova Gorica – Ljubljana (110km)

Sredstvo	Neposredni stroški	Čas potovanja
Avtobus	Vozovnica 10.70eur	2h32'
Vlak	Vozovnica 9.56eur	3h14'
Kia Rio	Gorivo ~12eur	1h15'
Renault Zoe	Najem baterije ~5eur + + elektrika VT~2eur/MT~1eur	1h15'

- Baterijski avto izgleda zmagovita tehnologija
- Razvoj baterijskih vozil je šele na začetku!
- Potrebujemo polnilnice doma in na delovnem mestu
- Javne polnilnice so nesmiselne in zelo drage!
- Razumno polnjenje vozil: prilagojen tok in izbira ure polnjenja ne ruši elektroenergetskega omrežja, pač pa povečuje življenjsko dobo in zmogljivost baterij (>10%)
- Celoten servis baterijskega vozila pri vulkanizerju
- Zahtevno popravilo karamboliranega vozila?
- Stroški baterijskega avta 1:2 proti bencinarju
- Prihranek energije je teoretsko 1:2, ob upoštevanju psihologije (počasne pridem dlje!) celo 1:3 ali 1:4

Sklepna misel:

Na bencinski črpalki vsakokrat
plačam eno bombo za
Bližnji Vzhod in
povrhu dobim še begunca!