

**Installation and Operation Manual**



**PROFITRACKER CL**

Installation and Operation Manual

# PROFITRACKER CL

Installation and Operation Manual

Issue **3.3** of 20.4.2012



-EQUIPMENT-GESELLSCHAFT für INTERN.  
ELEKTRONIK SYSTEME GmbH

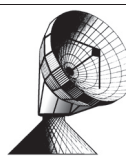

Flut-Str. 34-36  
D-63071 OFFENBACH/MAIN  
TEL. (+49) 69/858327  
FAX. (+49) 69/857863  
E-Mail: [Sat@EGIS.eu](mailto:Sat@EGIS.eu)  
<http://www.EGIS.eu>

*25 minutes from Airport Frankfurt • 25 minutes from Frankfurt City*

# Installation and Operation Manual

## PROFITRACKER CL

### Table of Contents

Contents	Page
Explanations for the issue at hand	1
Table of contents	2
Function description	3
System overview of the outside unit	4
Abutment load (mast payload)	5
System overview of the Controller	6
Safety regulations	7
Type label/rating plate	8
Technical data and specifications	9
Dimension sketch of outside unit	10
Mast - Rotator connection with mounting details	11
Assembly, Installation, Start-up and Maintenance	12
Mechanical assembly	13
Electrical installation	14
Details of the Controller	16
Electrical Fuses of the controller	17
Electrical fuses of the rotator	18
Start-up, Adjustment and Verification	19
Description of test runs	Annex I
Description of Referenz-/ORG- switch	Annex II
Communication interface and comand list	Annex III
Advanced Program-functions list	Annex VI
Basic manual for details	Annex VII
'Parameter List' of positioner	Annex IX
Manufacture declaration	Annex XI



**-EQUIPMENT-GESELLSCHAFT für INTERN.  
ELEKTRONIK SYSTEME GmbH**

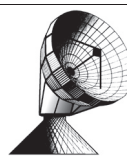

Flut-Str. 34-36  
D-63071 OFFENBACH/MAIN  
TEL. (+49) 69/858327  
FAX. (+49) 69/857863  
E-Mail: [Sat@EGIS.eu](mailto:Sat@EGIS.eu)  
<http://www.EGIS.eu>

*25 minutes from Airport Frankfurt • 25 minutes from Frankfurt City*

# Installation and Operation Manual

## PROFITRACKER CL

### Functional Description

The PROFITRACKER CL serves biaxial positioning of antennas.

Both axes (azimuth and elevation) possess their own control- & monitoring logic inclusive of incremental-sensor. By this sensor, the progressive movement of the axis is signalled to the control in form of electrical pulses.

In order to be able to allocate these ‚relative‘ movements to an ‚absolute‘ angle position, one must emanate from a fixed and known starting point. Both the axes are equipped with such an ‚organisation/origin detector‘ in form of a microswitch.

In the Azimuth-axis, the detector/switch is situated at the eastern end of the drive, in the elevation at the lower travel end - just below the horizon.

During the start-up, both the axes turn towards the particular ‚Org-point‘ and from there to the target angle. The angle progress is continuously counted and calculated.

Given that the ‚Org-switch point‘ could possibly be defective due to constructional incorrectness, the target position is accordingly inaccurate. Therefore the system requires a one-time calibration of the approached position.

In the so-called ‚Teach-Mode‘, a manual correction is driven towards the target using the keys ‚higher/lower‘ and/or ‚right/left‘ the correction-angles obtained in this process are stored by the controller and will be considered for all future objective positioning.

Like the DC-motors, the feedback-pulses and ORG-switches are 24 V operated. Feedback-pulses are recorded permanently. Even at times the motors are not running. It is therefore necessary that the external unit (the rotor) is permanently energised by the controller.



-EQUIPMENT-GESELLSCHAFT für INTERN.  
ELEKTRONIK SYSTEME GmbH

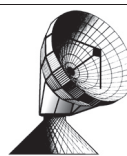

Flut-Str. 34-36  
D-63071 OFFENBACH/MAIN  
TEL. (+49) 69/858327  
FAX. (+49) 69/857863  
E-Mail: Sat@EGIS.eu  
<http://www.EGIS.eu>

*25 minutes from Airport Frankfurt • 25 minutes from Frankfurt City*

## System overview outside unit

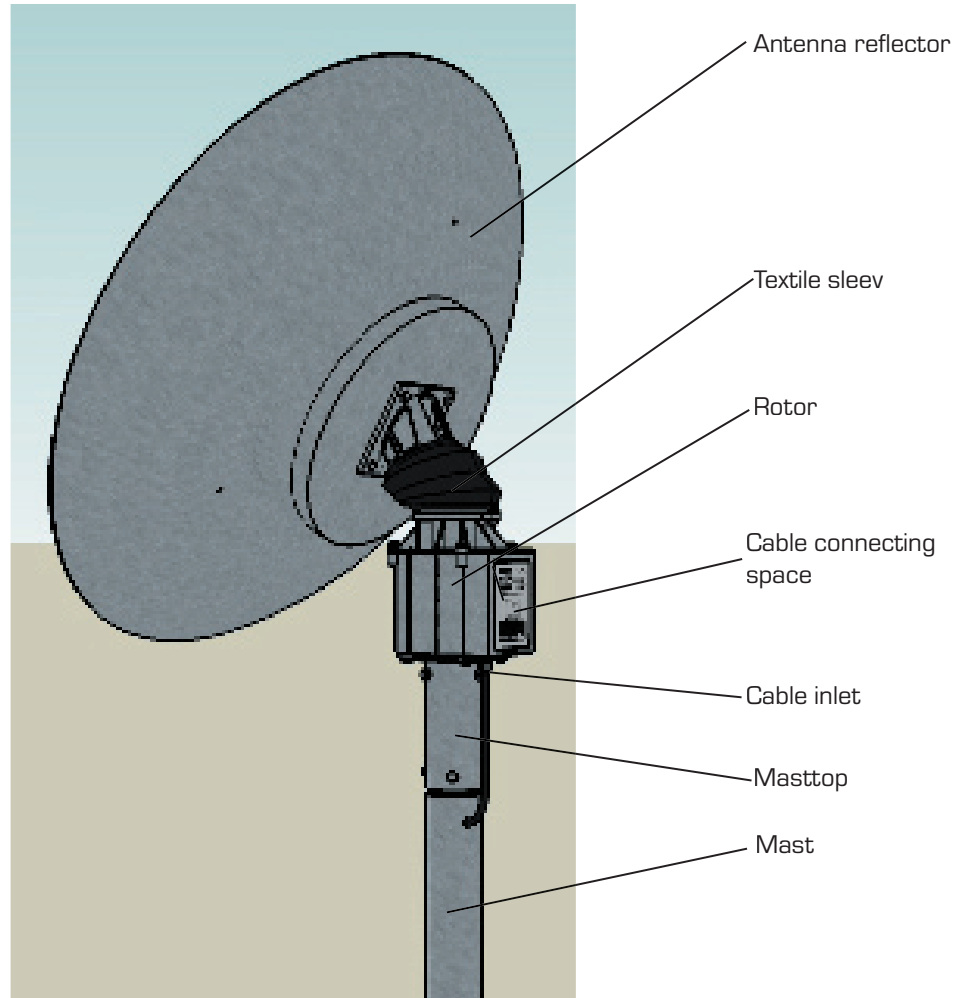

-EQUIPMENT-GESELLSCHAFT für INTERN.  
ELEKTRONIK SYSTEME GmbH

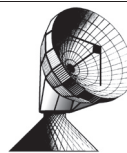

Flut-Str. 34-36  
D-63071 OFFENBACH/MAIN  
TEL. (+49) 69/858327  
FAX. (+49) 69/857863  
E-Mail: [Sat@EGIS.eu](mailto:Sat@EGIS.eu)  
<http://www.EGIS.eu>

*25 minutes from Airport Frankfurt • 25 minutes from Frankfurt City*

# PROFITRACKER CL

## Abutment load (mast payload)

**Static load:** max. **2000 N** (resulting out of Tara, cable weight and snow/rain (water) load) (Vector **A**)

**Dynamic load:** max. acceptable effective **vertical** forces at the rotor about **4500 N** (Vector **B**)

The max. acceptable effective **horizontal** forces at the rotor about **5000 N** (Vector **C**).  
(This forces may act in all horizontal directions).

**Attention:** At smaller planes appropriate minor loads are resulting!

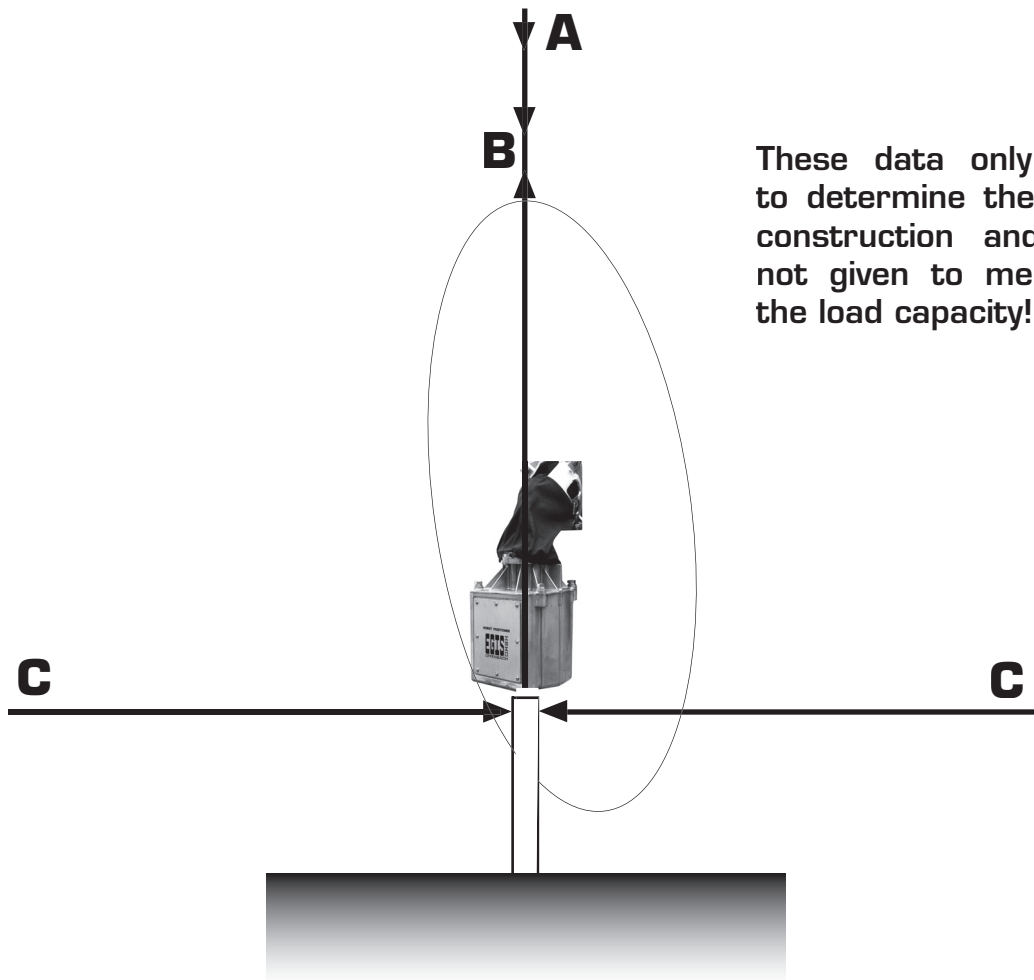

1099/008



-EQUIPMENT-GESELLSCHAFT für INTERN.  
ELEKTRONIK SYSTEME GmbH

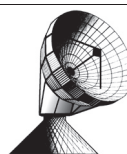

Flut-Str. 34-36  
D-63071 OFFENBACH/MAIN  
TEL. (+49) 69/858327  
FAX. (+49) 69/857863  
E-Mail: Sat@EGIS.eu  
<http://www.EGIS.eu>

25 minutes from Airport Frankfurt • 25 minutes from Frankfurt City

# Installation and Operation Manual

## PROFITRACKER CL

### Rotor/Controller system diagram

#### Steuergerät / Controller

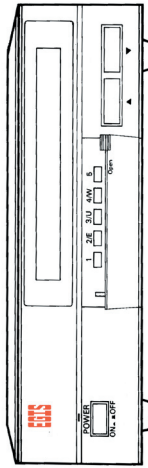

Außer der Netz-Versorgung (230V AC) des Steuergerätes werden nur galvanisch getrennte Klein-Spannungen mit 24 V DC genutzt!  
 Except for the mains supply (230V AC) for the controlling device, there are only used galvanically separated low voltages with 24 V DC!

Distanz zwischen Steuerung und Rotor: bis 100m  
 distance controller to rotator: up to 100m

Windsensor  
 Anemometer

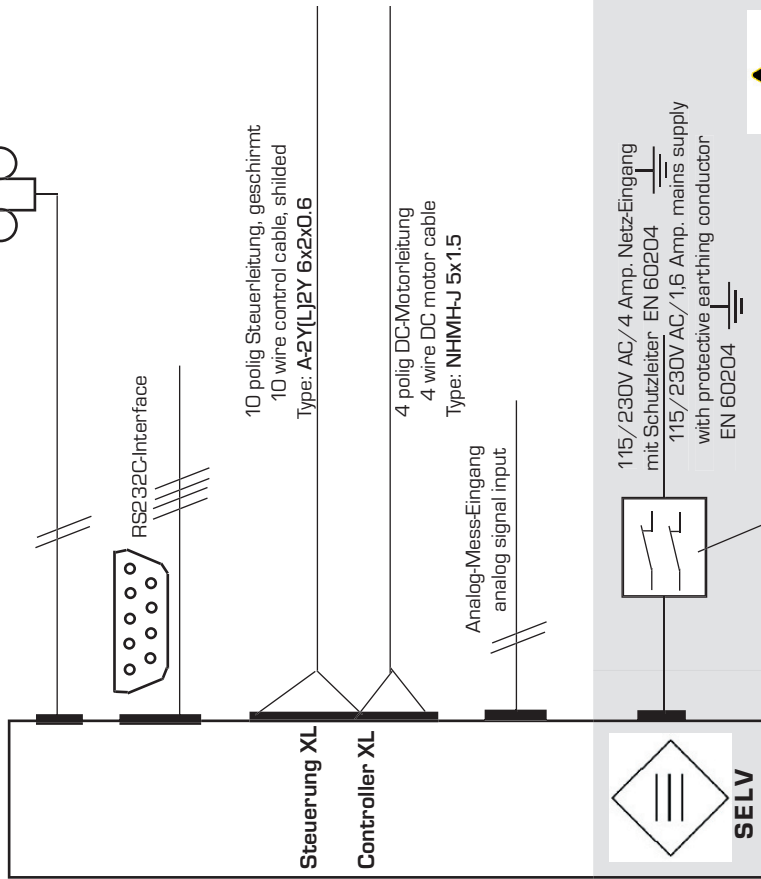
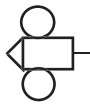

#### Controller - Rotor connections:

- 1 = EL puls A
  - 2 = unused
  - 3 = EL puls B
  - 4 = unused
  - 5 = AZ puls A
  - 6 = unused
  - 7 = AZ puls B
  - 8 = Messe/ground
  - 9 = EL org switch
  - 10= AZ org switch
  - 11= unused
  - 12= Org switch common
  - 13= + 24V DC
  - 14= - 24V DC
  - 15= EL-DC-Motor
  - 16= EL-DC-Motor
  - 17= AZ-DC-Motor
  - 18= AZ-DC-Motor
- Kontakte/contacts  
 2, 4, 6, 8, 11 & 14 are common ground

#### Rotor / Rotator

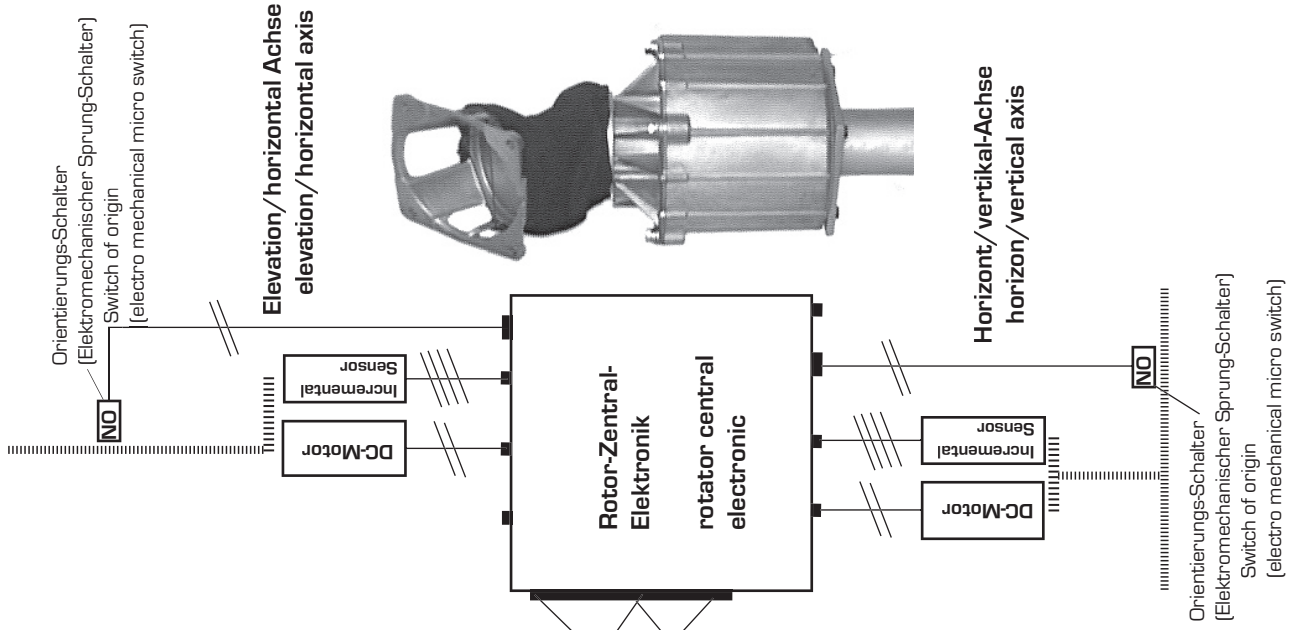

# Installation and Operation Manual

## PROFITRACKER CL

### Intended Purpose:

The system is only intended for the deflexion of sunrays. Any other kind of operating mode or usage is not admitted.

### Safety Regulations for Assembly, Installation, Maintenance and Operation

The application of the installation, operation and maintenance manual as well as the test specifications are prerequisites for the operation.

A threat analysis has to be established for the works on the system.

All kinds of assembly, installation and maintenance works may be carried out by trained/ on the job instructed personnel only.

During the assembly, installation and maintenance, the personnel at site has to wear personal protective equipment. For this kind of machinery and this project it includes: protective gloves, hard hat, safety goggles and safety shoes.

For all kind of assembly, installation and maintenance activities, which exceed a working height of 2 m, approved aerial working platforms have to be used. There are no devices provided to secure height-utility work machines.

All cranes, chain suspensions and other suspensions being used during the assembly, installation and maintenance must have a safe working load of at least 0,3t.

During the assembly, installation and maintenance lubrications may occur; therefore it is necessary, with regard to the used substances, to wear the respective type of protective clothing. The material data sheets must be adhered to.

Adequate lighting must be provided for assembly, installation and maintenance works.

During all assembly, installation and maintenance works on the mechanical rotor-head of the machinery, the entire system must be without current and the all pole mains switch has to be secured against any start-up by mistake.

No assembly, installation and maintenance works must be executed in normal/ standard operation mode.

Those adjustment and maintenance works on the mechanical rotor-head of the machinery, which require an electrical run mode ready for motion are only admitted with two on the job instructed persons: One person must permanently stay at the controlling device and must at all moments be ready to immediately stop the system. The two persons have to agree beforehand on how they will communicate with each other.

The machinery must not be used to move loads.

The machinery must not be used for transport of persons.

All parts of the machinery are laid out for a wind speed of 33 m/sec. maximum. Therefore all structural elements, assembly units and conditions on the part of the building site must be able to bear this load and to resist it respectively.

The mechanical interface between the rotor head of the machinery and the masts on the part of the building site has to be laid out accordingly [see page 11].

The masts have to be grounded.

The electrical interfaces between the control and the rotor-head of the machinery and the local A.C. network have to be laid out according to the wiring diagram of the system [see page 6 & 15].

In conformity with the technical data sheet, a general inspection by the manufacturer with regard to stability and mechanic as well as electric safety is required.

Only genuine parts from the manufacturer are admitted.



EQUIPMENT-GESELLSCHAFT für INTERN.  
ELEKTRONIK SYSTEME GmbH

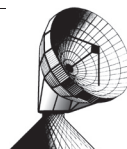

Flut-Str. 34-36  
D-63071 OFFENBACH/MAIN  
TEL. (+49) 69/858327  
FAX. (+49) 69/857863  
E-Mail: [Sat@EGIS.eu](mailto:Sat@EGIS.eu)  
<http://www.EGIS.eu>

25 minutes from Airport Frankfurt • 25 minutes from Frankfurt City



# Installation and Operation Manual

## PROFITRACKER CL

### Type label:

Position of the type label on the machinery: at the backside of rotator.

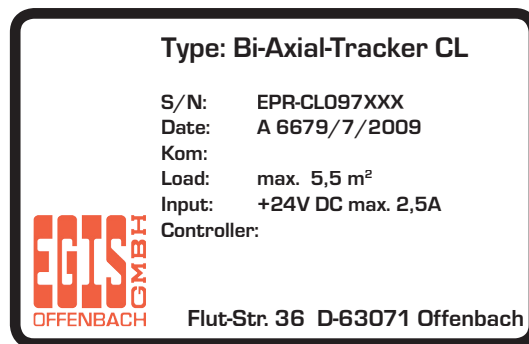

-EQUIPMENT-GESELLSCHAFT für INTERN.  
ELEKTRONIK SYSTEME GmbH

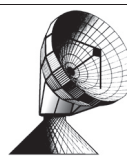

Flut-Str. 34-36  
D-63071 OFFENBACH/MAIN  
TEL. (+49) 69/858327  
FAX. (+49) 69/857863  
E-Mail: [Sat@EGIS.eu](mailto:Sat@EGIS.eu)  
<http://www.EGIS.eu>

*25 minutes from Airport Frankfurt • 25 minutes from Frankfurt City*

# Installation and Operation Manual

## PROFITRACKER CL

### Technical data and specifications

Manufacturer: EGIS-Equipment GmbH  
FLUTSTR. 34-38  
D-63071 OFFENBACH/MAIN  
Tel. (+49) 69/858327  
Fax (+49) 69/857863

Site of erection:

Designation: Bi Axial Solar Positioning System 'PROFITRACKER CL'

Serial number:

Year of manufacture: 2004

Manual-Issue: 3.1

Dead weight: 30 kg

Reflexion-area: max. 5 m<sup>2</sup>

Max. Wind load: 30 m/sec.

Electr. Power supply: AC 230 V / 1,6 Amp/ with protective earth conductor

Internal operating-voltage: DC 24 V

Standards for maintenance:

1. Visual inspection for loose screws and loose structural parts, at the latest three months after setting into operation; functional check of the wind sensor.
2. Afterwards, a visual inspection for loose screws, loose structural parts and fissuring, as well as a functional check of the wind sensor have to be carried out at intervals of 6 months.
3. After 5 years, a general inspection by the manufacturer is necessary, with regard to the stability and mechanical as well as electrical safety of the system.



-EQUIPMENT-GESELLSCHAFT für INTERN.  
ELEKTRONIK SYSTEME GmbH

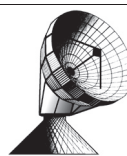

Flut-Str. 34-36  
D-63071 OFFENBACH/MAIN  
TEL. (+49) 69/858327  
FAX. (+49) 69/857863  
E-Mail: [Sat@EGIS.eu](mailto:Sat@EGIS.eu)  
<http://www.EGIS.eu>

*25 minutes from Airport Frankfurt • 25 minutes from Frankfurt City*

# Installation and Operation Manual

## PROFITRACKER CL

### Rotor details overview

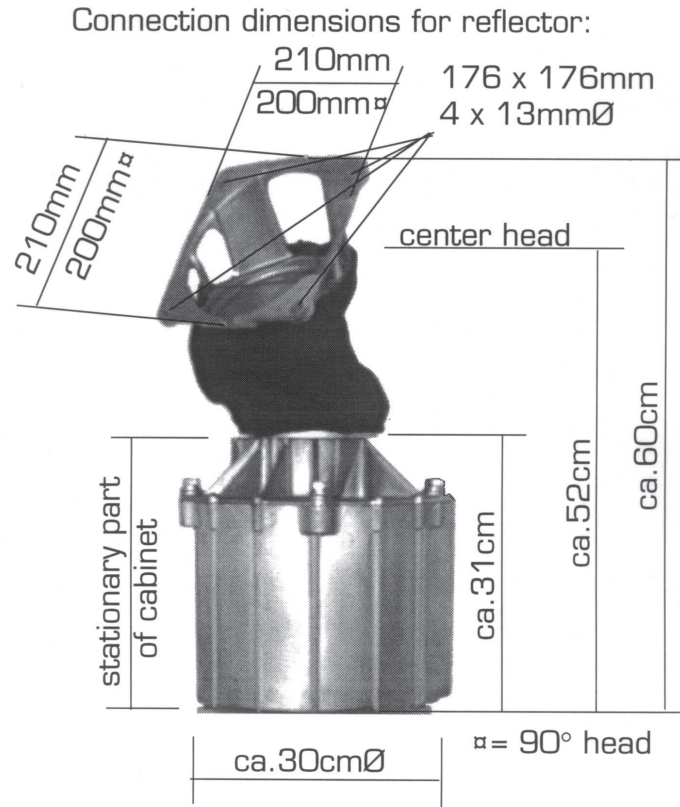

### Connection dimensions for mast table

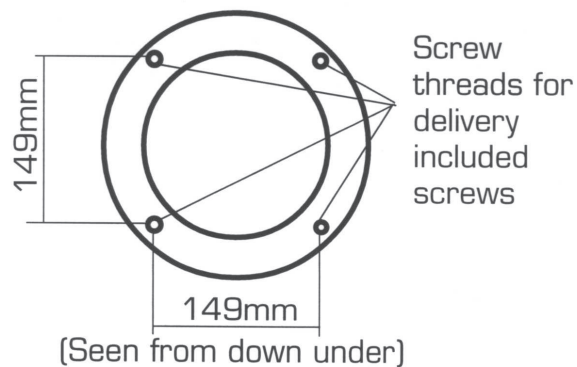

EQUIPMENT-GESELLSCHAFT für INTERN.  
ELEKTRONIK SYSTEME GmbH

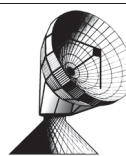

Flut-Str. 34-36  
D-63071 OFFENBACH/MAIN  
TEL. (+49) 69/858327  
FAX. (+49) 69/857863  
E-Mail: Sat@EGIS.eu  
<http://www.EGIS.eu>

25 minutes from Airport Frankfurt • 25 minutes from Frankfurt City

# Installation and Operation Manual

## PROFITRACKER CL

### Mast - Rotator Connection

Shown here the rotator without canvas collar: This canvas collar under all circumstances must protect the head mechanics and may never be removed! Read the manual!

In order to utilize the full elevation range of the drive mechanism, care must be taken when installing the drive mechanism (Switch basket) on the supporting surface, that parts of the mechanism protrude from the bottom of the housing into the mast (approx. 80 mm or 3-1/4"). If these parts of the drive mechanism hit a hard surface during operation, they may be destroyed! The corresponding opening must have a diameter of 80 mm (3-1/4").

Another frequent mounting error is damaging the rotor limit switches by the mast top. This happens, when a too reduced mast is inserted too deep into the rotor which causes destruction of the mast due to the rotor's own weight. Therefore do not take a mast smaller than the opening in the top of the masttop!

Tubular masts which are open at both ends, are primarily used for installing the rotor head. Unfortunately, these tubes cause a so-called "chimney effect", which means that humid air is sucked in from the outside at the lower open end of the tube, rises upward towards the rotor due to thermal effect and precipitates on its surfaces as moisture. This can cause electrical problems.

We therefore recommend to:

- Seal the tubular mast permanently with a durable plug or cover e.g. by welding, plugging with foam, etc. Please observe that the thermal effect becomes particularly evident, when the tubular mast terminates underneath the roof!

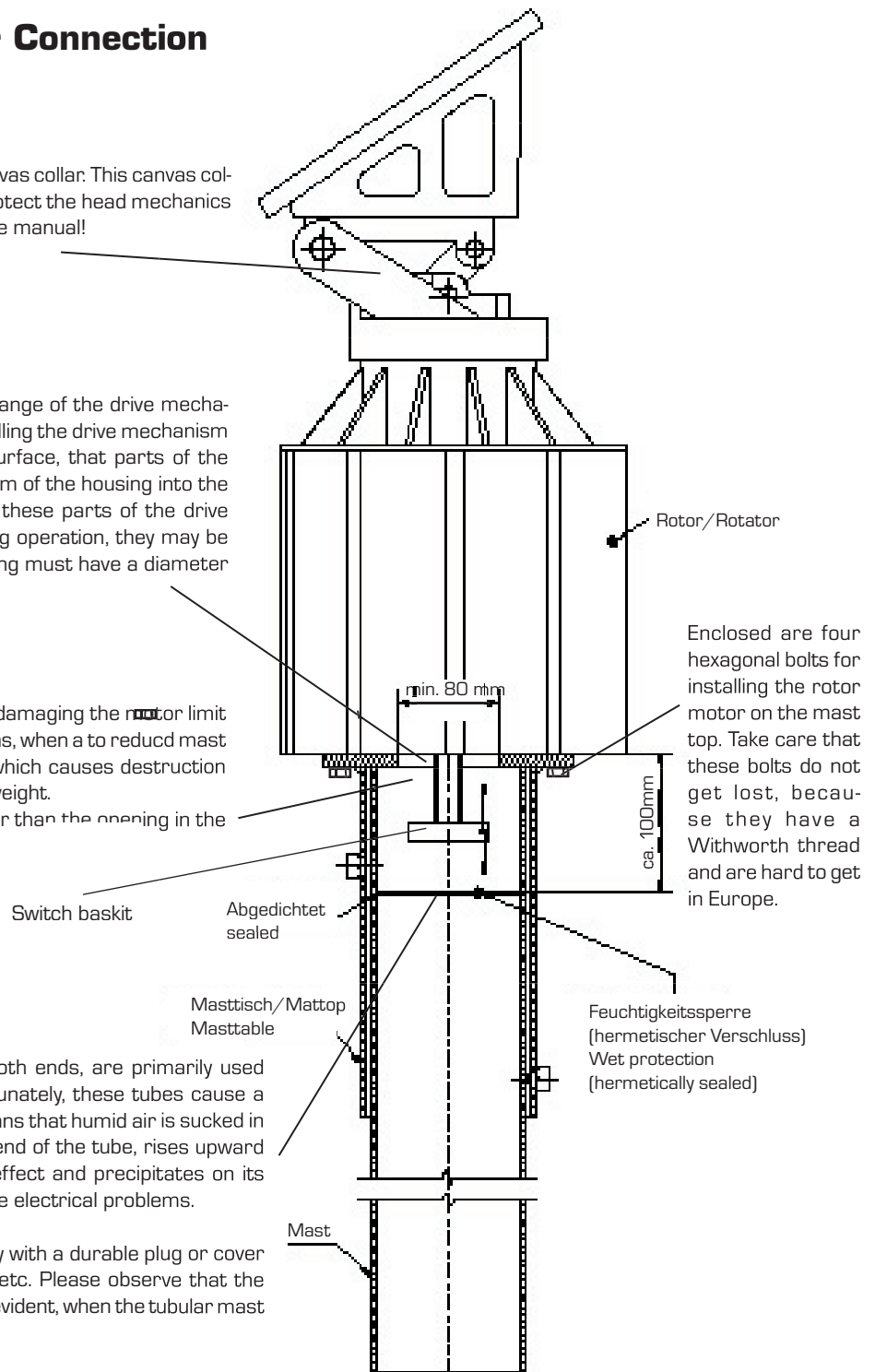

EQUIPMENT-GESELLSCHAFT für INTERN.  
ELEKTRONIK SYSTEME GmbH

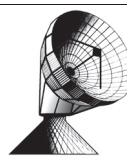

Flut-Str. 34-36  
D-63071 OFFENBACH/MAIN  
TEL. (+49) 69/858327  
FAX. (+49) 69/857863  
E-Mail: Sat@EGIS.eu  
<http://www.EGIS.eu>

25 minutes from Airport Frankfurt • 25 minutes from Frankfurt City

# Installation and Operation Manual

## **PROFITRACKER CL**

### Assembly, Installation, Start-up and Maintenance

#### Mechanical Assembly

- Mechanical Assembly page 13

#### Electrical Wiring

- Electrical wiring page 14

#### Start-up, Adjustment and Verification

- Start-up, Adjustment and Verification page 19

#### Maintenance

- Test Run Annex I  
- Reference / ORG-Switch Annex II



**-EQUIPMENT-GESELLSCHAFT für INTERN.  
ELEKTRONIK SYSTEME GmbH**

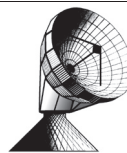

Flut-Str. 34-36  
D-63071 OFFENBACH/MAIN  
TEL. (+49) 69/858327  
FAX. (+49) 69/857863  
E-Mail: [Sat@EGIS.eu](mailto:Sat@EGIS.eu)  
<http://www.EGIS.eu>

*25 minutes from Airport Frankfurt • 25 minutes from Frankfurt City*

# Installation and Operation Manual

## PROFITRACKER CL

### Mechanical Mounting

#### Rotator & antenna carrier:

• Tubular masts which are open at both ends, are primarily used for installing the rotor head. Unfortunately, these tubes cause a so-called "chimney effect" which means that humid air is sucked in from the outside at the lower open end of the tube, rises upward towards the rotor due to thermal effect and precipitates on its surfaces as moisture. This can cause electrical problems.

We therefore recommend to:

• Seal the tubular mast permanently with a durable plug or cover e.g. by welding, plugging with rockwool, foam, etc. Please observe that the thermal effect becomes particularly evident, when the tubular mast terminates underneath the roof!

- The Rotator should be installed in following way:
- Mounting/Inserting of the Masttop/Masttable for the Rotator
- Alignment/Levelling of the Masttop/Masttable (see drawings A)

• When aligning the Masttop/Masttable make sure that one lateral edge of the assembly plate runs as exactly as possible in north-southern direction. Simultaneously use a exact spirit level (drawings A & B) for the plate of the Masttop/Masttable. We recommend to use an electronical spirit level.

• The reference or measuring area is the plane, upwards-showing surface of the masttop/masttable

• Having exactly aligned/levelled the device, tighten all fixing/adjusting screws (drawing A-1 & B-1) without again inadjusting the carrier!

**The exacter this work has been done, the exacter the Tracker will work!**

• Mounting/Suspension and Alignment of the Rotor (drawing C). Align the rotor corresponding to the direction mark "North" on the housing (drawing D-1). (These screws are delivered and marked with ,Y'). (Watch out: These screws have an American inch thread!)

• Fixing of the panel carrier:

Fasten the carrier plate/panel carrier to the rotor head without canting it and using the provided 4 pc. M12-hexagon-bolts (fig. G).

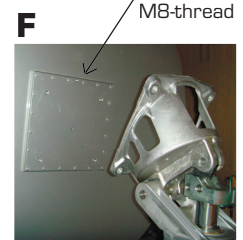
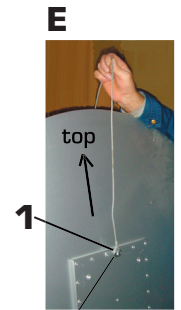
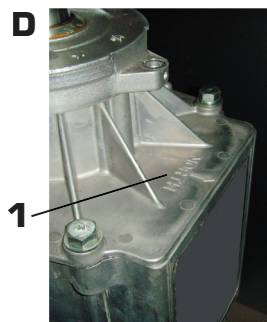

EQUIPMENT-GESELLSCHAFT für INTERN.  
ELEKTRONIK SYSTEME GmbH

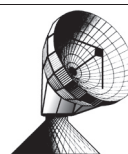

Flut-Str. 34-36  
D-63071 OFFENBACH/MAIN  
TEL. (+49) 69/858327  
FAX. (+49) 69/857863  
E-Mail: Sat@EGIS.eu  
<http://www.EGIS.eu>

25 minutes from Airport Frankfurt • 25 minutes from Frankfurt City

## Installation and Operation Manual

# PROFITRACKER CL

### Electric Wiring:

Between rotor and controlling device there are two different electrical connections:

- For the two DC-motors 4 wires with larger cross-section and
- For the return-sensors 10 wires with small section.

These two cables must be led separately. The joints to the return-sensors must have a cover (see also appendix „**Ro-  
tor/Controller-Verdrahtung/wiring**“).



**-EQUIPMENT-GESELLSCHAFT für INTERN.  
ELEKTRONIK SYSTEME GmbH**

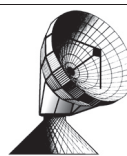

Flut-Str. 34-36  
D-63071 OFFENBACH/MAIN  
TEL. (+49) 69/858327  
FAX. (+49) 69/857863  
E-Mail: [Sat@EGIS.eu](mailto:Sat@EGIS.eu)  
<http://www.EGIS.eu>

*25 minutes from Airport Frankfurt • 25 minutes from Frankfurt City*

# Installation and Operation Manual

## PROFITRACKER CL

### Rotor/Controller wiring

**Kabel-Empfehlung:**

für den **Innen-Bereich:** J-Y(ST)Y 6x2x0.6 (Steuerkabel)  
 oder  
 TKD LIYCY 12x0.5 N4CE (Litze)  
 NYM-J 5x1.5 (Motor-Leistungskabel)

**Cable recommendation:**

for **inhouse** use: J-Y(ST)Y6x2x0.6 (control)  
 or  
 TKD LIYCY 12x0.5 N4CE (lace)  
 NYM-J 5x1.5 (motor power)

für den **Außen-Bereich:** A-2Y(L)2Y 6x2x0.6 (Steuerk.)  
 NHMH-J 5x1.5 (Mot.-Leistungskabel)

for **outside** use: A-2Y(L)2Y6x2x0.6 (control)  
 NHMH-J 5x1.5 (motor power)

Geräte-Ausführungen die zum schalten der Motore mechanische Relais benutzt, benötigt **keine** Abschirmung.

Versions using mechanical relais to switch the motors, do **not** need shielded cables.

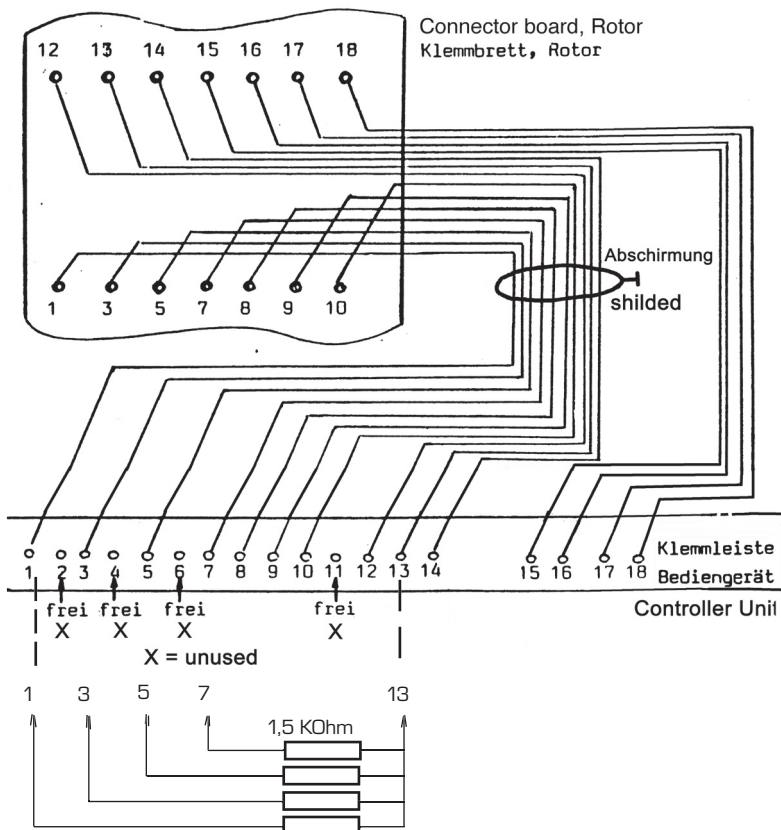

Die Kabel-Abschirmung mit der Gehäuse-Masse verbinden - **nicht** mit der elektronischen Geräte-Masse (**COM**)!

Connect the cable shield with the case ground only - **not** with the electronic ground (**COM**)!

Bei Störungen und Störmeldungen die eventuell aus langen Kabelführungen und/oder größeren, von Außen kommenden auf das Kabel wirkenden Störbelastungen, kann - durch eine höhere Bestromung der Rückführ-Leitungen und -Signale - eventuell eine Verbesserung erreicht werden. Dazu sind die vier Rückführ-Leitungen mit zusätzlichen elektrischen Lasten zu versehen. Je Leitung ist ein Widerstand mit ca. 1,5 KOhm bei 0,5 Watt Belastbarkeit nach nebenstehender Skizze einzusetzen. Innen-Widerstand im Steuergerät: ca. 2 KOhm

If interference and erratic messages are occurring, which are generated by extended cables and/or from outside generated electrical noise taking effect on the cable, improvements may be made potentially by using higher operating currents for the feedback-lines and signals. This can be realized by using additional electrical loads on the four feedback-lines. Therefore are serving load-resistors with a value of round about 1,5 kOhm respectively and a power capability of 0,5 watt (see circuit diagram aside).

Eine weitere Maßnahme ist die Heraufsetzung des **TIMEOUT** der Rückführ-Impulse. Mit **PRG 38** kann die Zeit verlängert werden, in der Impulse zurück kommen müssen und somit ist das „Fenster weiter geöffnet“. Es werden damit ggf. auch verlagerte Impulse erfaßt.

One further measure is setting higher the restoring pulses's **TIMEOUT**. Using **PRG 38** the time can be prolonged, in which the pulses have to come back, resulting in a „wider opening of the window“. By this any shifted pulses can be captured, if necessary.

0604/004



**-EQUIPMENT-GESELLSCHAFT für INTERN. ELEKTRONIK SYSTEME GmbH**

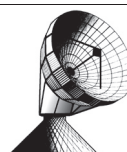

Flut-Str. 34-36  
 D-63071 OFFENBACH/MAIN  
 TEL. (+49) 69/858327  
 FAX. (+49) 69/857863  
 E-Mail: Sat@EGIS.eu  
 http://www.EGIS.eu

25 minutes from Airport Frankfurt • 25 minutes from Frankfurt City



# Installation und Operation Manual

# PROFITRACKER CL

## Controller (desktop version)

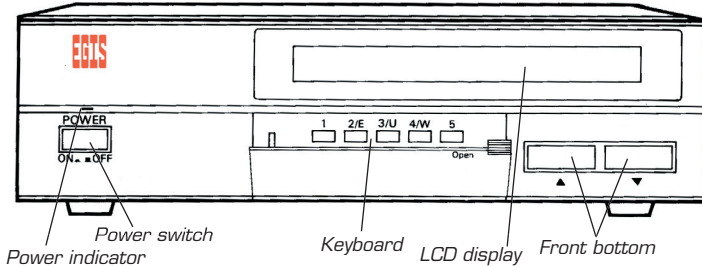

Power switch, Power indicator, Keyboard, LCD display, Front bottom

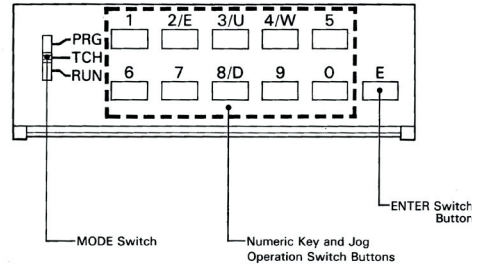

MODE Switch, Numeric Key and Jog Operation Switch Buttons, ENTER Switch Button

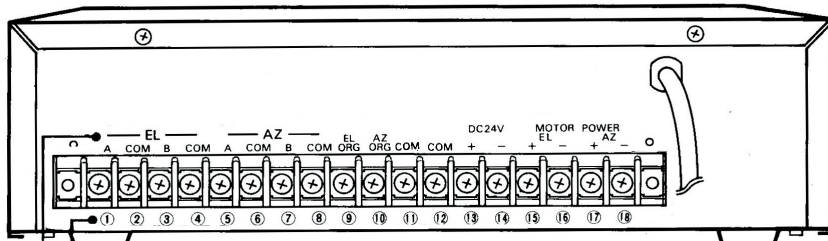

**Note**

When using an external cable consisting of 14 wires, COM ②, ④, ⑥, and ⑪ are not to be connected.

- |             |        |   |  |
|-------------|--------|---|--|
| EL          | A      | ① | ..... A-phase pulse input terminal for elevation position detection.                         |
|             | COM    | ② | ..... A-phase pulse input return terminal for elevation position detection.                  |
|             | B      | ③ | ..... B-phase pulse input terminal for elevation position detection.                         |
|             | COM    | ④ | ..... B-phase pulse input return terminal for elevation position detection.                  |
| AZ          | A      | ⑤ | ..... A-phase pulse input terminal for azimuth position detection.                           |
|             | COM    | ⑥ | ..... A-phase pulse input return terminal for azimuth position detection.                    |
|             | B      | ⑦ | ..... B-phase pulse input terminal for azimuth position detection.                           |
|             | COM    | ⑧ | ..... B-phase pulse input return terminal for azimuth position detection.                    |
|             | EL ORG | ⑨ | ..... Elevation home position switch input terminal.   |
|             | AZ ORG | ⑩ | ..... Azimuth home position switch input terminal.   |
|             | COM    | ⑪ | ..... Elevation home position switch and Azimuth home position switch input return terminal. |
|             | COM    | ⑫ | ..... Elevation home position switch and Azimuth home position switch input return terminal. |
| DC24V       | +      | ⑬ | ..... DC power output terminal for and encoder phases A and B                                |
|             | -      | ⑭ | ..... DC power output terminal for and encoder phases A and B                                |
| MOTOR POWER | EL     | ⑮ | ..... Elevation motor drive power output terminal (24 VDC output).                           |
|             | -      | ⑯ | ..... Elevation motor drive power output terminal (24 VDC output).                           |
|             | AZ     | ⑰ | ..... Azimuth motor drive power output terminal (24 VDC output).                             |
|             | -      | ⑱ | ..... Azimuth motor drive power output terminal (24 VDC output).                             |



**-EQUIPMENT-GESELLSCHAFT für INTERN. ELEKTRONIK SYSTEME GmbH**

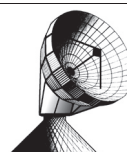

Flut-Str. 34-36  
D-63071 OFFENBACH/MAIN  
TEL. (+49) 69/858327  
FAX. (+49) 69/857863  
E-Mail: Sat@EGIS.eu  
<http://www.EGIS.eu>

*25 minutes from Airport Frankfurt • 25 minutes from Frankfurt City*

# Installation and Operation Manual

## PROFITRACKER CL

*Pos. der elektrischen Schmelz-Sicherungen*

*Pos. of electrical fuses:*

frontside

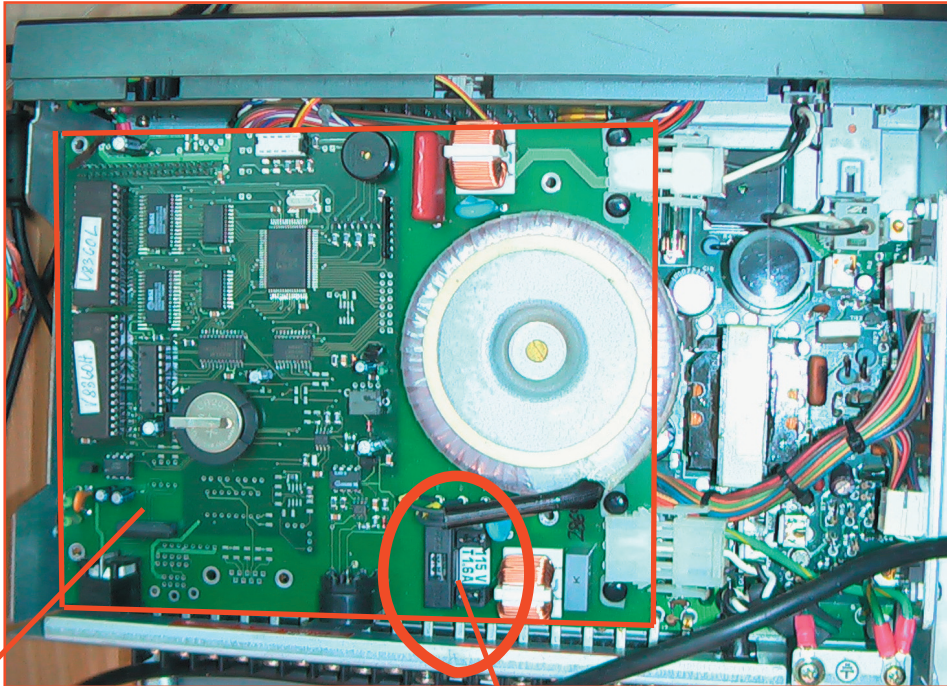

Upper board

Lower board

Fuse for line power protection.  
I = 1,6 AMP. (115V)  
I = 0,8 AMP. (230V)

frontside

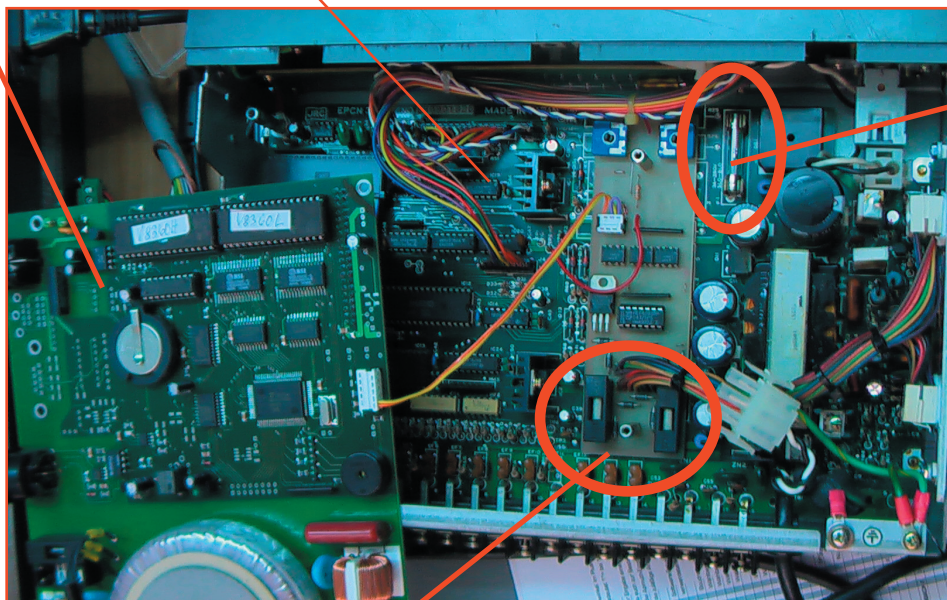

Fuse for logic & motors  
I = 3 AMP.

Fuse for motors powersupply.  
I = 2.5 AMP. Value of fuse can be vary  
according use model and motors.



**-EQUIPMENT-GESELLSCHAFT für INTERN.  
ELEKTRONIK SYSTEME GmbH**

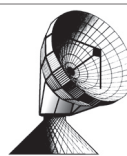

Flut-Str. 34-36  
D-63071 OFFENBACH/MAIN  
TEL. (+49) 69/858327  
FAX. (+49) 69/857863  
E-Mail: Sat@EGIS.eu  
<http://www.EGIS.eu>

*25 minutes from Airport Frankfurt • 25 minutes from Frankfurt City*

# Installation and Operation Manual

## PROFITRACKER CL

### Klemmen- & Sicherungen-Board im Rotor

### Connectors & Fuses-Board internally of Rotator

Fuses

Connectors

frontside

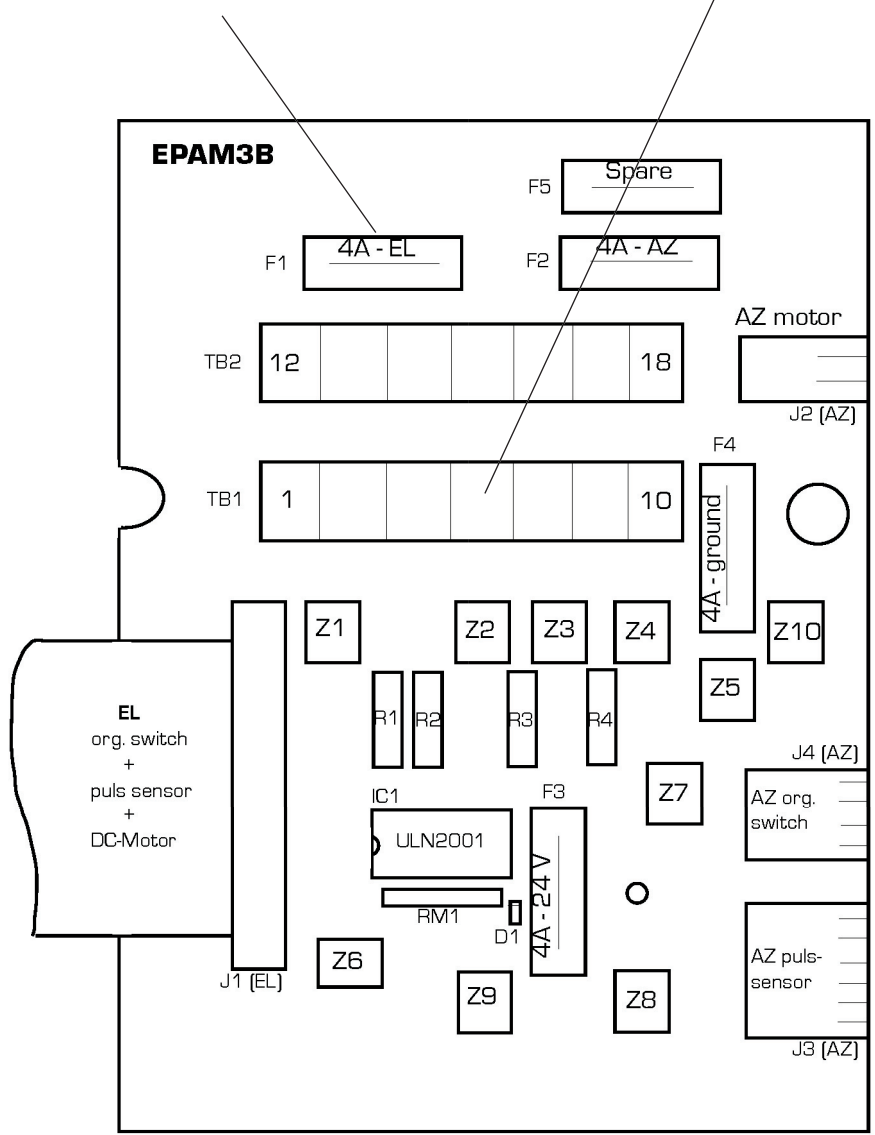

**-EQUIPMENT-GESELLSCHAFT für INTERN. ELEKTRONIK SYSTEME GmbH**

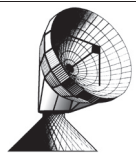

Flut-Str. 34-36  
 D-63071 OFFENBACH/MAIN  
 TEL. (+49) 69/858327  
 FAX. (+49) 69/857863  
 E-Mail: Sat@EGIS.eu  
 http://www.EGIS.eu

25 minutes from Airport Frankfurt • 25 minutes from Frankfurt City

# Installation and Operation Manual

## PROFITRACKER CL

### Adjustment, verification and setting to operation:

Please note: When a solar-tracker-system is newly set to operation, after a change of firmware in the controlling device, after repair works carried out on the rotor or on the controller and also after a 'RamCheck' with **PRG 17**, the controlling device must again be provided with all 'operational and working parameters' of the rotor. This includes e.g. the rotor's range of movement, the location of the system, the start-up-process- and braking parameters and others (see 'parameter table' of the used rotor).

You will find here all basic information regarding the handling of the controlling device:

- Switch on the controlling device pressing the front key **ON/OFF** and **directly afterwards** press the **programme-key (PRG)** (upper key). **PRG** is displayed and the cursor starts flashing on the right.
- Enter '**17 RAM CHECK**' is displayed. Enter the password „**1199**“ with 'E'nter and wait, until '**00064 KB / 00256 KB VERIFID**' or '**00512 KB VERIFID**' appear on the display. Finish with 'E'nter. All old data of the memory are deleted now and from the EPROM, the operation-programme has been freshly loaded into the memory.
- Dial **PRG 01** (switch to **PRG- (program mode)** and enter '**01**'), then enter (**LOCATION**) and the coordinates (**LAT**itude & **LON**gitude) of the location (decimally! this means **not** using ‚minutes‘ & ‚seconds‘). Finish with 'E'nter.
- Dial **PRG 22. 'ROTOR TYPE'**. Here the controller must be equipped with the movement range of the rotor (see 'Parameter Table' of the rotor). Address with the right/left- arrow keys and select with the Up/Down- arrow keys. Finish with 'E'nter.
- Dial **PRG 21 (LIMIT)**. Limit the slewing range eventually.
- Dial **PRG 52**. Check/set up time (UT!) and date. Finish with 'E'nter. (UT= **Universal Time**).
- Now switch over to »**R**«UN (lower position). Use the front keys to dial up a satellite, which is located preferably south from the system. (During the first start-up, an '**ORG**'-Run is carried out automatically). Also the **Sat-receiver** or the **radio** has to be set on a programme, which sends on this satellite, das auf. If the mechanical assembly of the rotor has been done very exactly, a good picture will be seen now. But the antenna will probably just "look" –more or less– aside the satellite. Therefore please
- Press the key »**5**« in the »**T**«CH mode. The antenna will then start its search by scanning concentrically around the calculated starting point. As soon as you can see the corresponding TV-programme on your TV-set, stop again using key »**5**«. Should you find out that the found satellite is the wrong one, you just press key »**5**« to start the search- run again and stop it anew with »**5**« on reception.
- In case the **AGC**-connection to the Sat-receiver is already established and adequately levelled out, now an auto-focussing run can be performed by pressing the key »**0**«. (If you have not proceeded as far as that in the process, please continue here :)
- Set the mode switch on »**T**«CH and optimise the reception by using the keys **2** (EAST), **3** (UP), **4** (WEST), **8** (DOWN).
- Then press the key »**7**« and afterwards »**E**«nter to correct the values for all satellites.
- Switch over to »**R**«UN and dial up any desired other satellite (if necessary, do the fine-tuning in the »**T**«CH-mode individually via »Autofocus« [press "**0**"] or manually using the keys **2** (EAST), **3** (UP), **4** (WEST), **8** (DOWN) and save with »**E**«nter (not with "**7**" and "E"nter).
- In **PRG 02 (ORG POINT)** you are now able to read out all captured **angle-correction-values** for both of the axes. These values should be taken down for later use.
- If all settings and fine-tuning-measures are carried out to the optimum, you should now be able to unerringly select any desired satellite (in "RUN"-mode)! This selection can be effectuated sequentially as well as numerically by using the two arrow keys on the keypad.
- To select a satellite-position numerically, press the 'E'nter-key and afterwards enter the number of the desired satellite (always in **three digits**).



**-EQUIPMENT-GESELLSCHAFT für INTERN.  
ELEKTRONIK SYSTEME GmbH**

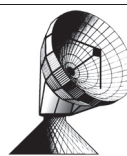

Flut-Str. 34-36  
D-63071 OFFENBACH/MAIN  
TEL. (+49) 69/858327  
FAX. (+49) 69/857863  
E-Mail: [Sat@EGIS.eu](mailto:Sat@EGIS.eu)  
<http://www.EGIS.eu>

*25 minutes from Airport Frankfurt • 25 minutes from Frankfurt City*

# Installation and Operation Manual

## PROFITRACKER CL

### Test Run

In all work steps of the assembly and also in daily operation, it might turn out necessary to check/ to test the external functioning of the 'Two-axial positioning-system'. Due to the fact that such a test run, as the case may be, could already be required immediately after starting the assembly, that is, at a point where the operator still is not too familiar with the system, we draw up this separate instruction for a test run. This step-by-step instruction will disclose the essential requirements.

Before you start to move the head of the rotor, make sure that no person (!) as well as no objects are to be found in the rotor's range of movement!

- Join the cables between the two-axial rotor (fig. C) and the controlling device (fig. B). This can be carried out by using an provided, ready-to-plug test-cables (fig. B), but you can also use the already laid definite cable.

- Provide the controlling device with AC-mains power (or in case you have the DC-version with the device-specific direct current voltage [12 or 24V]).

- Switch on the controlling device pressing the front key (fig. A) and directly afterwards press the programme key (marked with 'PRG').

- The cursor in the display starts flashing and signalsises that an entry is required. To get into the **test-mode**, you have to enter '99' on the ten-digit-keyboard.

For each movement axis (Azimuth & Elevation) a three figure digital indicator (of the return-pulse counter) and a switch-symbol (of the original switch [ORG]) become visible in the display (fig. E).

As soon as one of the frontal direction keys (fig. F) is actuated (up, down, left, right) the belonging (AZ or EL) three figure pulse-indicator must change.

For a test [Azimuth] use the right arrow key to drive the rotor-head somewhat direction west, and then, using the left key, to the east. The digital indicator, which belongs to this axis, should add the return pulses when driving direction west and when driving east subtract them. Shortly before the total end of the travel (in the east) has been reached, the opened switch-symbol, which belongs to this axis and which is left of the three figure number must close itself. Now stop immediately. In order to release the switch you drive a bit west, if necessary.

During elevation you have first to drive up a bit (upper arrow key) and then down again (lower key), until the symbol of the elevation-switch shows that you have reached the switch of origin (fig. E). Here also the symbol-switch should shut itself shortly before travel-end and open again when driving upwards.

During elevation the return pulses should be added when moving upwards and subtracted when moving down.

Information: When the absolute mechanical limit is approached during this process, the motor will be stopped immediately and an error message will be displayed.

If the required results have been achieved, the preceding procedures can be continued.

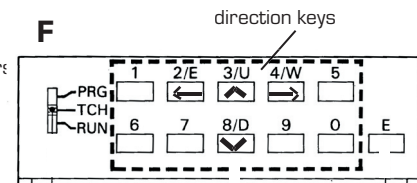
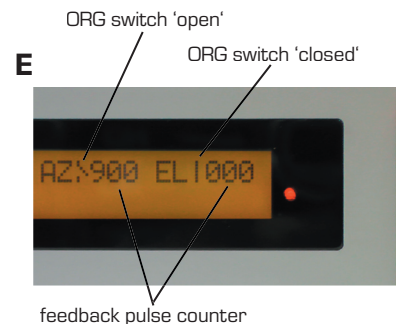
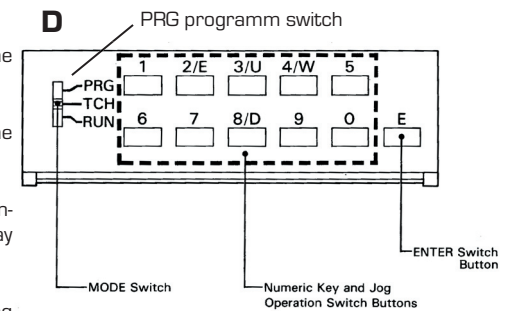
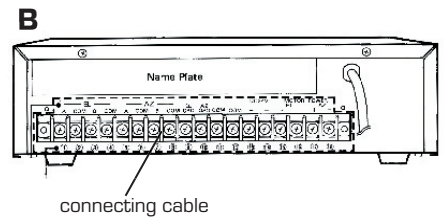
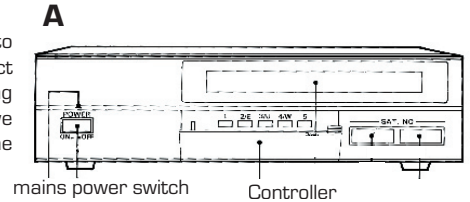

EQUIPMENT-GESELLSCHAFT für INTERN.  
ELEKTRONIK SYSTEME GmbH

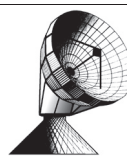

Flut-Str. 34-36  
D-63071 OFFENBACH/MAIN  
TEL. (+49) 69/858327  
FAX. (+49) 69/857863  
E-Mail: Sat@EGIS.eu  
http://www.EGIS.eu

25 minutes from Airport Frankfurt • 25 minutes from Frankfurt City

# Installation and Operation Manual

## PROFITRACKER CL

### Reference-/ORG switches

Every axis (azimuth and elevation) is equipped with one reference switch (Annex II/ 1).

The reference-/ORG-switches serve as "Start-" and/or "Reference"-points for the controller to regulate the position of the turning knob within the rotor:

On the azimuth-axis, this "ORG"-switch has been positioned shortly before the eastern end of the moving hub (fig. B) - in the elevation just below the horizon.

Electro-magnetic micro-switches are used as "reference/ORG-switches". The switches are normally opened (NO) and will close, when activated by the relevant ORG-trip cam.

In PRG 98, the switching state of the reference-switches (ORG) for both axes (azimuth & elevation) is dynamically shown by a switch symbol inserted on the display (fig. D).

Die ORG-trip cams are placed internally of the rotor head.

All wiring connections of the ORG-switches are leading directly to the controller.

The switching states of the ORG-switches can be monitored on the display of the controlling device (fig. D): Dial in PRG-mode (upper position of the switch) and PRG 98.

This is the function sequence of an ORG-run:

Both of the axes are simultaneously moving towards the ORG-switch. As soon as a switch is reached, the axis stops and remains in this position for 1-2 seconds. Then this axis turns backwards, until the ORG switch is released again and stops there. This position is the ORG-switch point. The procedure is the same for both of the axes.

It is also possible to trigger an ORG-Run manually: In 'Teach-Mode' (middle position of the switch) using key '9'.

An ORG-Run will be triggered automatically

- After a new start-up of the control unit
- After a change in firmware/ operating software
- After a randomized change in position within PRG 98
- After a power-cut which happens when a motor is running.

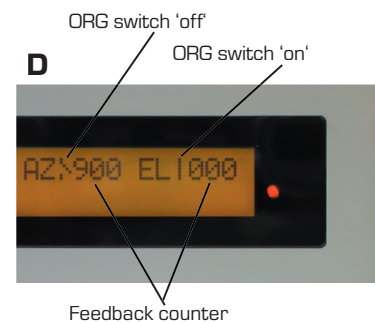

EQUIPMENT-GESELLSCHAFT für INTERN.  
ELEKTRONIK SYSTEME GmbH

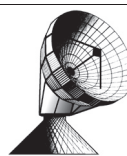

Flut-Str. 34-36  
D-63071 OFFENBACH/MAIN  
TEL. (+49) 69/858327  
FAX. (+49) 69/857863  
E-Mail: Sat@EGIS.eu  
<http://www.EGIS.eu>

25 minutes from Airport Frankfurt • 25 minutes from Frankfurt City

# Communication Interface PROFITRACKER

**Very important notice: all connections should be done in power down condition only, and before switchng on the control unit and computer!**

The used computer has to be connected via a **zero-modem**-cabel to this interface. This is a cable reversing data and handshake path. If you are using a terminal programm set "**echo on**" till finding the proper transfer mode on your computer: It is not recommended to use **hardware handshake** initially.

See **program memory 95** for detailedled service haelp: automatic sending of all lower-set ASCII characters in bursts of 5 sec. onto externally connected computer. Display will show received ASCII data from pin 2 (**RXD**) and line status from pin 8 (**CTS**) & 7 (**RTS**) of D-SUB-connector:

Connector:	9polig	D Sub	double row
Interface:	RS 232 C		
Protocoll:	8N1	(8 bit/no parity/1 stop bit)	
Baud Rate:	Baud rate can be set via PRG 23. Preset to 1200 Baud.		
Hardware handshake:	CTS can be activated and disabled via PRG 23		
Ground Reference:	Cabinet/ non-fused earth wire		

**Contact Assignment:**

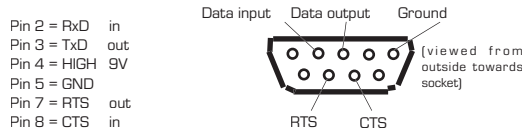

All commands must start with a two digit password. Factory preset is "&\*" (ASCII DEC 38 + 42 HEX 26 t 2A). Other combinations may be entered via **program memory 24**. With the exception of this password and the commands all other blank spaces and symbols outside the 7 bit ASCII codes are removed by filtering. Capitals and small letters have identical functions. All comandes must be finished by a **CarriageRetourn (CR)** [ASCII DEC 14 10 HEX \$0D \$0A]. No further orders can be entered during an instruction is processed!

The Command list you find on the next page.

012/04/0032



**-EQUIPMENT-GESELLSCHAFT für INTERN.  
ELEKTRONIK SYSTEME GmbH**

Flut-Str. 34-36  
D-63071 OFFENBACH/MAIN  
TEL. (+49) 69/858327  
FAX. (+49) 69/857863  
E-Mail: [Post@EGIS.eu](mailto:Post@EGIS.eu)  
<http://www.EGIS.eu>

*25 minutes from airport Frankfurt • 25 minutes to Frankfurt City*

# Communication Interface PROFITRACKER

## Command list via RS232-interface

Internal arithmetical accuracy: **0.01°.**

Commands are subdivided into the following 2 groups:

**Direct commands:** to issue and read updated instant-action instructions  
**Program commands:** to establish functional and program parameters

<b>Direct Commands:</b>	<p><b>AZ=000.00</b> Goto azimuth angle 000.00 (0.01 bis 360°)  <b>EL=000.00</b> Goto elevation angle 000.00 (0.01 bis 90°)</p> <p><b>AZ=?</b> Recall present azimuth angle  <b>EL=?</b> Recall present elevation angle  <b>L1=?</b> Recall data value for analog input Port 1  <span style="padding-left: 100px;">(Numeral 2 for Port 2, 3 for Port 3 etc. to Port 4)</span></p> <p><b>P=000</b> Goto Satelliten no. XXX (conform EGIS satellites list)</p> <p><b>FOCUS</b> Perform autofocussing in both axis  <span style="padding-left: 100px;">(for units with analog input only)</span></p> <p><b>ORG</b> Perform orientation run (detect internal reference switches)  <span style="padding-left: 100px;">(see user manual for additional information)</span></p> <p><b>SATLIST=?</b> Recall compl. satellites table from memory  <span style="padding-left: 100px;">(This daten string includes:  <b>satellites no.; clarkbelt Pos.; satellites name (text or spaces); memorized AZ angle; memorized EL angle</b>                      Format:  <b>000 000,00 X XXXXXXXXXXXXXXXXXXXXXXXX AZ=000,00 EL=000,00.</b>                      Data words are separated by tabulators (ASCII DEC + HEX 09).</span></p> <p><b>AZROTATIIONS=?</b> Get 360° turn numbers  <b>AZROTATIONS=xnnn</b> Set 360° turn numbers (x='E'ast or 'W'est; n= 000up to 099 turns)  <b>STATUS</b> Get MOTOR STATUS in hexadezimal form (HEX)  <span style="padding-left: 100px;">0000 = AZ- &amp; EL-motor off 0000</span>  <span style="padding-left: 100px;">0002 = AZ-motor drives to west 0010</span>  <span style="padding-left: 100px;">0003 = AZ-motor drives to east 0011</span>  <span style="padding-left: 100px;">0008 = EL-motor drives up 1000</span>  <span style="padding-left: 100px;">000C = EL-motor drives down 1100</span>  <span style="padding-left: 100px;">000F = AZ- &amp; EL-motors running to east &amp; down 1111</span></p> <p><b>REBOOT</b> POWER ON RESET (reboot)  <b>ELTAB=?</b> Get ELEVATION-TABLE  <b>PRG88=?</b> Get ELEVATION-COMPAIR-TABLE FROM PRG 88  <b>PARAREAD</b> Read PARAMETER FROM MEMORY (details see next page)  <b>PARAWRITE</b> Store PARAMETER IN MEMORY (details see next page)  <b>VERSION</b> Get VERSION- &amp; SERIAL NUMBER  <b>HELP</b> Get ALL POSSIBLE SERIAL-COMANDS  <b>?</b> Get ALL POSSIBLE SERIAL-COMANDS</p>
<b>PROGRAMM-BEFEHLE:</b>	<p><b>ELFORCEBACK=1</b> Set POSITION-FORCE BACK ELEVATION ON  <b>ELFORCEBACK=0</b> Set POSITION-FORCE BACK ELEVATION OFF</p>

(If the rotor received a positioning command via the RS 232 interface, memory recalls are not possible, while the motors are running. If however, motor operations are initiated by means of the control unit (e.g. Autofocus mode) memories can be recalled any time.

**Only at actions caused by commands via the data interface an error-report is given out via the interface.**

The command **&\* FOCUSRESULT=1 (CR)** causes the rotor to display the results of one focussing run. Subject command also initiates the automatic repetition of this display after each focussing event, indicating the current azimuth and elevation positions as well as the correlated field strength -without entering an inquiry command (Field strength however will only be indicated when equipment with AGC Input is used). This operating mode can be disabled with the command **&\* RESULT=0 (CR)**. (Only useable with field strenght-depend auto-focussing). This command can also be entered via **program memory 31**, thus allowing to route the output data directly to a printer, a transfer or measuring station respectively when no computer assisted operation is available.

Data string:

**Row number; day; date; time; tracking channel; AZ angle; EL angle; AZ motor pulses; EL motor pulses; analog channel level 1; 3; 4. Format 1; 3; 4: 00000 Mon 22.06.98 15:23:44 01 00000 00000 00000 00000 0000 0000 0000**

Data words are separated by space. Row counters refer on the actual day and are being reset at midnight.

After being switched on, the unit transmits a stus message to the serial interface with **»EPS-103« »OK«**

After entering **&\* mit »OK«**

**Examples:** Recall AZ-Pos. 182.05°: **&\* [SPACE] AZ=182.05(CR)**  
 Report elevation position: **&\* [SPACE] EL=? (CR)**

012/04/0032



**-EQUIPMENT-GESELLSCHAFT für INTERN.  
 ELEKTRONIK SYSTEME GmbH**

Flut-Str. 34-36  
 D-63071 OFFENBACH/MAIN  
 TEL. (+49) 69/858327  
 FAX. (+49) 69/857863  
 E-Mail: [Post@EGIS.eu](mailto:Post@EGIS.eu)  
<http://www.EGIS.eu>

*25 minutes from airport Frankfurt • 25 minutes to Frankfurt City*



## Communication Interface PROFITRACKER ,En Bloc' parameter download & upload via RS232 interface

With this new package of commands, you are able to access all of the entered settings and parameters of an EPS-controller en bloc via - RS232 interface ñ and to save them on a personal computer. If required, the data can be transferred back to the controller later.

An important key condition is that the same firmware-generation (version) is used. For example, a file which has been created with V8053-firmware cannot be transferred and restored in a V8054-version.

From now on, it is therefore possible to access the version-number of the firmware via the serial interface.

Three commands characterize this package:

```
,VERSION'      - GET VERSION- & SERIAL NUMBER of EPS controller
,PARAREAD'     - READ PARAMETER FROM MEMORY of EPS controller
,PARAWRITE'    - STORE PARAMETER IN MEMORY of EPS controller
```

Once you have entered the command ,& \* PARAREAD' , the controller sends a text file, which could look like the following example:

```
S315004000000010250460000000000000000496E74656C15
S31500400010736174203730312020202020202020009A
S31500400020010288450000000000000000496E6D6172C3
to
S315004035C07C233B3B9C02E623DE3B8A024C24823C26
S315004035D06D02AE24243D5C020F25C83D4F026D2589
S315004035E06A3E44029E2668424402000000000000F3
S315004035F0000000000000000000023C1C000000000002B
S306004036000083
S503036198
00865 S3 ROWS TRANSFERED
V8053 : 000 2711
OK
```

In the case mentioned above, the file is composed of 865 lines.  
Each line contains a checksum.

Only lines beginning with an ,S' will be transferred.

By entering the command ,& \* PARAWRITE' these data can be sent back into a controller.

After a successful transmission, the controller answers with

```
00865 S3 ROWS TRANSFERED
OK
```

The following error messages might occur during this transmission:

```
WRONG CHARACTER IN HEX-FILE !   - There are illegal characters within the file!
WRONG CHECKSUM IN HEX-FILE !    - The file gives a faulty checksum!
```



# Installation and Operation Manual

## PC Communication Interface Wiring

### MODEM-KABEL-BELEGUNG zwischen PC (COMPUTER) & EGIS STEUERGERÄT

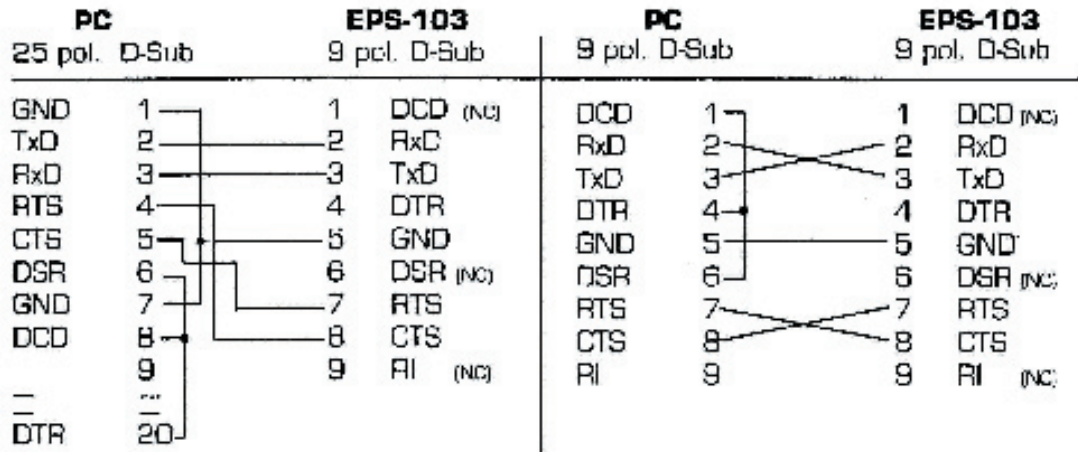

**-EQUIPMENT-GESELLSCHAFT für INTERN.  
ELEKTRONIK SYSTEME GmbH**

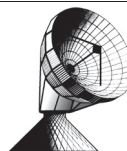

Flut-Str. 34-36  
D-63071 OFFENBACH/MAIN  
TEL. (+49) 69/858327  
FAX. (+49) 69/857863  
E-Mail: Sat@EGIS.eu  
<http://www.EGIS.eu>

*25 minutes from Airport Frankfurt • 25 minutes from Frankfurt City*

# Bi-Axial-Antenna-Controller



## EXTENDED PROGRAM FUNCTIONS

### Basis-V.: SATELLITEN-TRACKER

#	NAME	FUNCTIONS	BASIS F.	PROFI	MOTIONCONTRO	DATA	AZ390	EL90	GPS	GR-19	AutoTracker
1	ANT-LOC.	Input of the antenna location-coordinates	X								
2	ORG-POINT	Orientation point, for the mathematical correction of mechanical mounting-errors you may adjust the azimuth and elevation of the starting point related to the geographic north pole or plane ground (90 degrees vs. middle of the earth)	X								
3	SAT-NAME	Display readout of the elevation and azimuth angles of already with program "PRG01" calculated satellite positions	X								
4	SAT-LOC.	Free computer memory space for additional satellite position input and modification	X								
5	BACK LASH	A precoded number of pulses will be added to the motor controll to minimize mechanical errors of the gear when direction of motion is changing	X								
6	OFFSET AM + AM -	Number of pulses suppressed before motor reaches a certain azimuth position. These inputs are to be made separately for each direction and choosed in a manner, that the motor stops exactly at the target (of special interest when heavy antennas moved).	X								
7	OFFSET EM + EM -	As prog. 6 but for elevation	X								
8	TOLERANCE AM	Maximal number of pulses for antenna positioning error - when this value will be exceeded, an automatic correction follows.	X								
9	LOW SPEED (P1)	This number of pulses controls the time for low speed motor operation after start, before full speed is reached.	X								
10	LOW SPEED (P2)	This number of pulses controls the time after which the motor operates at low speed before stopping	X								
11	ORG PULSE AM EM	Number of pulses for the motor operation delay time after leaving the ORG-switch	X								
12	ORG TIME AM EM	Motor turning delay time after leaving ORG-switch	X								
13	JOG PULS COUNT	Step dimensioning in TCH-modus for each key pressing. Dimension of a single step.	X								
14	MOTOR REST	Idle time after each motor run (saving operation time using small antennas). There is a risk of see-saw effects with big antennas and too short motor-rest	X								
15	LCD CHECK	Self explaining	X								
16	SWITCH CHECK	Tests all switches, they have to be pressed in a certain order without greater pauses in this direction: 1. select program 16 and acknowledge with "E". 2. Set motor switch to "RUN". 3. Press "DOWN" button, then "Up" button. 4. et modus switch to "TCH". 5. After this activate/press individually the keys of the lower key row	X								
17	RAM CHECK	When doing this quick enough, without mistake and all keys working correctly, there will appear "OK" as a confirmation. Any error will be displayed as "NG" for "Not good". keys working correctly, there will appear "OK" as a confirmation. Any error	X								

CAUTION: Not all functions are available on all versions and for each operating mode.

									will be displayed as "NG" for "Not good".
18	RECEIVER-INTERFACE	X							Adjustable number of readjust-pulses/sat and number of pulses/sec. Default value is 20 pulses for each function. Menue-Window for the main type of sat-positioner. Default value is 00 (standard). Delay (10th of sec.) after choosing a satellite via receiver, for proofs and till motor start action. Preset: 10.
19	THRESHOLD & DELAY	X							Trigger for autofocus. Fieldstrength-changes related to the last accepted value lower than the preset THRESHOLD will not start the autofocus operation. To start the autofocus operation automatically the THRESHOLD value must last longer than than the preset DELAY time. This value has to be greater than the longest interference pulses.
	INVERT INPUT LEVEL (Y/N)	X							When switching to "y" the fieldstrength signal will be inverted. Low voltage: good signal, high voltage: weak signal.
	AUTOFOCUS FOLLOWS SAT SELECT (Y/X)								When Switching to "y" autofocussing starts once after choosing a satellite.
	AUTOTRACK FOLLOWS SAT SELECT Y/NX								When switching to "N" this question appears: Setting to "y" autofocussing will be permanent.
20	SEARCH ANGLE	X							Search angle. In this preset variation range the antenna will search around the theoretical satellite position. 1 means 1 degree plus/minus from starting point, default 9,9.
21	LIMIT	X							Input of the turning-limitation within one full-turn (starting at ORGpoint PRG 02. Limitation of turns in 360-degrees-operation. On azimuth settings below 360.00° the digits after the decimal-point are counting. Azimuth settings exceeding 360.00 degrees are numbers after the decimal-point, which are limiting the turnarounds in both directions. The setting of 360.04 is the limiting to 4 turns in each direction starting at the ORG-point (refere to PRG 93)
22	ROTOR TYPE	X							Software toggle to inform the control if an azimuth rotor for 180 degrees or 360 degrees is in operation. Same to the elevation span: 40 or 90 degrees. Preset: 180°/40°.
23	RS 232 INTERFACE		X						Baud rate for RS 232 Interface ( 300 to 76.800 baud) settable in 8 steps by botoms 3 & 8 and Enter. Hardware handshake (CTS) active/inactive
24	KEYWORD/CHARACTER			X					Password, choosable, 2 digits. Preset »&*<«
25	HIGHSPEED			X					Highspeed, choosable, relative (0-255). Preset: 255
26	LOWSPEED			X					Lowspeed, choosable, relative (0 - 2553). Preset: 60
27	SPEEDUP			X					Acceleration, choosable, relative (0 - 255). Preset: 5
28	SLOWDOWN			X					Break delay, choosable, relative (0 - 2553). Preset: 5
29	SERVO			X					Control delay, relative (0 - 255). Preset: 60
30	FOCUS INTERVAL		X						Focus repetition without physical Trigger (0 - 65535), Preset' 0
31	FOCUS RESULT				X				When "ON", showing AZ and EL angle with fieldstrength after each focussing operation
32	SEARCH STEP ANGLE			X					Input of antenna aperture. Preset to minimum 0.1 degree
33	PROGRAMM LOCK					X			Only rack version 19" : Set lock switch function: opening or closing (NC - NO) by key operation. Password 5545.
34	ORG. RUN SUPPRESSION		X						Suppression of ORG-point call. Protected by password: 2288, Rotor operation without steering to the eastern ORG-point Before using this feature set rotor head in Teach Mode exactly to south and EL in middle position.
35	DISPLAY SAT NAME		X						Possibility to fade out sat-name in RUN-operation

36	PARKPOSITION	X							Possibility to steer rotor in park position over both axis in any desired position preset by you. Not related to any other functions or actions.
37	TARGET CHAIN	X							Pinpointing all visible satellites one by one from east to west. Delay time adjustable in seconds.
38	TIMEOUT MOTORFEEDBACK	X							For safety purposes the time distances between the motor feedback pulses are steadily measured, detecting motor errors or blocking. Any errors will be displayed. When motor cables are too long ore under certain circumstances (snow, ice, storm) there is a possibility, that motors run too slowly. You may change the preset time (1 sec.) to a corresponding value.
39	FOCUS/TRACK ACTIVATOR	X							Set operation mode for selected satellites to trigger single focussing, permanent tracking or a single selection of respective satellite. Use keys „2“ & „4“ to select focus or tracking operation. Use „1“ & „6“ to select satellite and toggle with key „0“ between 'Yes and 'N'o. End with "E"nter.
41	GEAR RESOLUTION								GEAR 1 IIMP = AZ 0.0000° EL 0.0000°. Set the "pulse to angle rate" of your motor gear. You have to program the moving angle of the trough for 1 set of feedback pulses. The EL axis is unused.
40	WIND SENSOR	X							Setting and align wind sensor interface and/or '4-wire-interface'
42	GPS CAPTURE								In this program-memory you may take over global positioning data automatically from a GPS navigator/receiver via the serial interface into program-memory PRG 01 of the control-unit.
43	ORG POINT ADJUST								Used to align the elevation movement strock to the org-switch.
45	MOTOR SHUT DOWN	X							To switch off AZ or EL axis with key "0" (yes/no)
46	MIN STEP WITDH	X							Slightest step size in pulses. Default: AZ=0002 EL=0008
47	DISPLAY ANALOG CH.-NO.	X							Hereby you may determine the analog-channel to be displayed. The display shows a 8-bit word (3 digits): "0" no value to be displaye "1" analog input display (analog jack), marked as "A" "2" not used (till now) "3" internal backup-battery voltage display (marked "C" "4" motor power supply (marked "D" "5" wind speed display (shows wind speed instead of an analog value). "Wxxx" instead of an channel marker, "W" represents wind.
50	SUN WARNING	X							With these functions you get an early warning, before any dangerous situation occurs. Premise to the save use of this function is a correctly mounted antenna and a correct setting of the local values (PRG 01) and the date/time in PRG 52 (must be in UTI). Implemented in the control unit, an astronomical calculation-program using Kepler-data of earth and sun checks the sat-position for any such collision.If the warn-mode is activated, a buzzer warns the user whenever the warning-limits are exceeded. You may also induce a swing-out automatically. 0 = off; 1 = buzzer; 2 = automatic swing-out; 3 = buzzer and automatic swing-out
51	SUN WARNING								Display the actual sun position
52	TIME & DATE								Set time and date: The first window is showing time. Close with "E"nter. Second window shows actual date. Set values by "3" (UP) and "8" (DOWN). Toggle fields with The safety-angle for the warning can be set here, the increments represent the time before
53	SUN WARNING								the sun reaches the focus and a warning/swing-out is performed. Here you may preset the warning-angle in angle-degrees,
54	SUN WARNING								before the sun reaches the focus and a warning/swing-out is performed.
91	WWWWWWWWWWW	X							W

92	AZ-ROTATIONS	X					360° revolution counter. Meaning of, e.g., "E002": rotor was driven 2 revolutions into eastern direction from ORG point 2. Meaning of "W001": rotor has been driven 1 revolution into western direction. By overwriting this value other positions can be entered - within the limits preset in PRG 21. This PRG place is active only when 360° rotor is used (PRG 22).
93	ANALOG-ADJUST	X					Matching analog (fieldstrength) signal, coming from test point, onto positioner control unit. Set zero value till level display shows 005 using key "1" and "6" (ZERO), tune gain level (GAIN) to 2.10 at the highest appearing test signal value using keys "2" and "7".
94	90°-HEAD CORRECTION TABLE	X					You may correct any unlinearitys of the 90 degrees positioning in the elevation range punctuell or tabellaric (see extra sheet).
95	RS 232 TEST			X			Automatic transmission of all characters in the lower ASCII-code to an externally connected computer every 5 seconds. Received ASCII-data from pin 2 (RXD) and line data frompin 8 (CTS) and 6 (RTS) of D-SUB-jack are displayed.
96	EPROM CHECKSUM	X					Display of the EPROM checksum.
97	REVEIVER-PULS-SYNCHRONISATION	X					Possibility to synchronize the sat-receiver via motoropulse-interface. Use "2" (EAST) or "4" (WEST).
98	MOTOR SENSOR MONITORING	X					Switching information of the reference-switch (ORG-switch displayed as a switch symbol) and pulse sensing on the motors axis (displayed as a 3 digit number). You may test the function of the motor incremental sensors by pushing 3(UP), "8"(DOWN), "2" (EAST) or "4"(WEST) and watching the pulse numbers. If any error of the control panel occurs, you may override this by typing the password 3377. Then the motor function is no longer monitored, there is a risc of burning-out the motors when are activated and blocked at the same time.
99	IDENTIFICATION	X					Displays manufacturing date and software version

V7039 + V8035 + V8209

Use the button "Ø" to toggle between YES/NO

706.009



**BI-AXIAL-ANTENNA-ROTOR**

This installation and operating manual does not contain any general build-up orders for satellite reception equipment. In each particular case the knowledge and the experience of a qualified antenna technician is required - this is for both equipment as well for handcrafting. A good source and a wide survey in satellite technics offers e.g. the book SATELLITEN-EMPFANG of PAUL VAN ROSSUM edited in the ELEKTOR-Verlag.

Already here - just in the beginning of the manual- we tell you, that we know each manual is worth to improve. This one included! However, before you totally condemn this little booklet, we ask you to consider, that it is not written as an unique manual for a common consumer product, but for a high sophisticated product, built only in small number of pieces each by each - and permanent changes and completions have to be learned and considered. Technical advantages, functional improvements and other add-on's are to be inserted into the existing text. Thereby may occur some over-, or also underemphasizes - belonging to the actual shape of the editor. Please accept that, we have done our very best.

But do not accept any errors belonging to facts. Please let us know, if anything is wrong, incorrect or causes any misunderstanding. We beg you to send us your well respected informations. Please accept -already now- our best thanks for helping us. This Manual is written for operators, which have fun and pleasure with the product.

**In order to use all the possibilities of this rotor optimally, we urgently recommend to read the attached „enlarged program function“-list and study it systematically!**

**Scope of delivery:**

- A. 1 Item rotor with added PG-screw. and spare fuse at rotor fixes.
- B. 1 Item control unit with spare fuses.
- C. 1 Item AGC connection cable
- D. 1 Item 4-wire cable to the receiver **optional:**

If you are not still familiar with this Bi-Axial-Antenna-Rotor; we recommend a test installation without any antenna. Pre-install the system at your bench or in your workshop. Thereby you can test and watch the reaction of the rotor system, try out and get familiar. We have seen it again and again, that these effort is worth while. An additional information right now: everything you change and type in during this tests can be simply deleted with the help of simple commands and can be reset in the **original state of manufacture**.

**Please note:** There are some rotor-types for which an electronic correction of the EL-angle is made and provided by the manufacturer. These correction-data are filed/saved by default in the buffered RAM of the control unit, and additionally on CD (CompactDisk). Control units which are equipped with the EELAC-tag (Electronic\_Elevations\_Angle\_Correction) are provided with this data-load. Caution! In this case do not execute the **RAM-check** described below! Should the check still be needed, the correction-data will have to be loaded again from the provided CD to the control-unit (Description of this process see "**Automatically Recording of Elevation by Inclinometer**").

**Important:** Smaller antennas can be mounted onto the rotor-head without counterbalance. Heavier weights need balancing, whereas the antennas load center should be as far as possible central in the AZ-axis. If necessary, use a counterbalance to balance out (this can be made later on too).

Not corresponding to that considered in the preceding, we recommend to choose the position of the counterbalance in a way, that there is a slight excess weight to one side in all elevation angles. Possible tolerances causing inaccuracies are eliminated this way and eventual additional noise will be reduced.

**Control panel overview:**

From time to time the system will ask the operator for decisions in the form of „Y“/„N“ (yes/no). Thises switchover is managed by the key „0“ (zero), back and forth switching. Algebraic signs „+“ and „-“ are carried out by pushing keys „3“ (UP/upwards) and „8“ (DOWN/downwards).

**The control unit operates in 3 operational modes:**

The **programmer (PRG) mode** (slide switch [under the front lid] in the upper position). Left „PRG“ will appear in display. In this mode you may set-up operational parameters and you will receive some information.

The **learn (TEACH) mode** (slide switch to the right in the center position). Appearing: „TCH“. Herein it is possible to drive to any desired rotor position and to save that sat position or a satellite in one of the memories, if you like.

The **normal (RUN) mode** (switch in lower position). Appearing: „RUN“. Here you may recall any already stored sat-position.

**Function of the keys:** in „Tch mode by pressing **2** (EAST/East), **3** (UP/upward), **4** (West/West) and **8** (DOWN/down) the electric current for the respective motors is switched on. Even if you press them permanently, the motor operates only for a very short period of time (Micro stepped). Only when pressing them longer than about 1 sec. the motor operates permanently - till you are stopping to press the key.

**Important for understanding:** Do not mix up **program-memories** and **satellite-memories**. There are **99 PRG-memories** and **400 satellite-memories**. Till now **350** of these sat-memories are operational. The keys of the numeric keyboard under the front lid feature another function in each mode.

The display of these equipment version will show more informations than originally planned. That's the reason why the initials were once again shortened: „RUN“ is marked „R“ and „TCH“ is marked „T“. „SAT“ is replaced by „S“. Working in „FOCUS“ modus, in certain working conditions direct a „F“ (focus) appears beside additionally. Between the SAT-names incl. their geostationary sat-position and the AZ-angles the relative field strength is indicated with a resolution of 254, marked by a leading „L“ (= Level). See sketch.

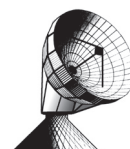

## Supplementary Installation and Operation Instructions

# BI-AXIAL-ANTENNA-ROTOR

The control unit of the „ProfiTracker“ without 'MOTION CONTROL' includes a low speed reduction action about **50%** (preset).

In **program memory 9** you may determine, according to how much motor feedback impulses occur; the time after the rotor starts moving and then switches to full speed. With **PRG 10** it is possible to determine the input pulse figure before motor-stop switches to the **lower speed**.

With the option **MOTION CONTROL** you are able to reduce **controlled-till near to zero**. The version no. of the firmware can be shown by recalling program memory **99 (PRG 99)**. For a quick information press a key in repetition.

If you use the rotor in the **southern** hemisphere, the orientation mark „**NORTH**“ has to **target south**.

### Connection between Rotor and Controller:

Rotor and control unit are connected via a 14-wire cable.

**Attention:** Be careful and disconnect the control unit from the power line!

Remove the cover at the rotor unit and the plastic cover over the terminal strip at the control unit backside. The **terminals 1 to 18** are free accessible now. Connect wire-by-wire all terminals (**1 to 1**). E.g. connect terminal 1 at the rotor terminal strip with terminal 1 at the control unit and so on.

The terminals 2; 4; 6; and 11 at the control unit's terminal strip are used internally and are not to be connected externally.

The cable screen must be connected to ground at both housings respectively.

The cable between to the motor output of your sat receiver and our receiver interface (4-wire) should not be connected yet.

At the rear of the control unit, right in the middle, there is the **analogous field strength signal input** (DIN socket/round contact arrangement).

The **AGC control voltage** of to the Sat-receiver/radio/scanner has to be applied here. Pin allocation: see sketch. A readily wired cable is attached (2 wires).

**To maintain all passive and active EMI-certifications (and thereby the device's approval) this cable should not be extended! The cable used should have a screen in any case! Keep it as short as possible.**

Some sat-receivers allow adjustments of the **AGC** voltage. This signal should be adjusted in a manner; that the receiver shows full deviation when the maximum possible field strength is still displayed.

For the adaptation of different sat-receivers output voltages (operating range **minimum 0.3 V to max. 12 V; maximum load up to 30 volts**) to the control unit the front-sided keyboard is used. (Read additionally annex text: **AGC adaption**).

The **AGC-jack** isn't to confuse with the **DIN-jack** left of it at the left-hand unit edge. This socket is the satellite receiver interface. A readily wired cable is attached (4 wires).

Now switch on sat-receiver and control-unit as well. The receiver must be tuned onto the desired program on the desired satellite and be ready for operation! After switching on the control panel the computer shows some various informations running in the display. During this time the unit performs a system-check automatically. This lasts about 10 sec.

You may now start to type in the geographic position of the antenna. However, we recommend to start first with **program memory 17** for a **RAM-Test**: According to the access to **PRG 17** (slide switch upwards and type in **17**) enter the password „**1199**“ and confirm with „**E**“nter: „**WAIT ...**“ and after about **3 sec.** you will see „**RAM CHECK 00064 KB VERIFIED**“ or „**RAM CHECK 00256 KB VERIFIED**“ in the display - the RAM is ready for operation! Finish with „**E**“nter:

After this RAM-Test the entire old-eventually still existing- data in the RAM are deleted and the complete default values are loaded from the EPROM into the processor for further processing.

At this time the controller should be informed via **PRG 22** about the used rotors moving range. You find the AZ and ELmoving angle at the backside of the rotor on the connector cover.

Now enter the position of the antenna via **PRG 01**. The entry must be decimal, that means i.e.: not **48°30'** but **48,50°**. At the northern hemisphere enter „**N**“ with the digit „**3**“. „**S**“ (southern) enter „**8**“, „**E**“ (eastern) enter „**2**“ and „**W**“ (west) enter „**4**“. The computing time following lasts about 60 sec. During this time you may watch on the display the proceedings when a satellite momentarily is being calculated.

After that switch the modus-switch onto „**R**“UN and choose a good receivable, powerful satellite as far as possible in the zenith, use the two keys for that. *Try out!*

Or you may use the keyboard with the direct numeric dialing: start with „**E**“nter; then type in the three-figure **sat number**.

**Please notice:** The Sat-Receiver or the measuring device must be tuned onto a program belonging to this satellite and ready to receive!

Because an automatic calibration run features a preview prior to this initial positioning operation (**ORG-RUN**), the settling time is a little bit longer than in the later normal operation. (See also **ORGPOINT-DRIFT**). In the display appears „**ORG**“. The rotor runs all east (reference-no) initially and later on to the lowest elevation and almost then secondary onto the selected target. Now watch the expected program on your TV or testing device - even though in bad quality - then proceed to the next step with Pos.B. Most Probably the „**Dish**“ does not pinpoint exactly the desired satellite because of mechanical installation-deviations or improper mounting. This, however, is no problem with this rotor for you.

**A.** Enter the „**T**“-Modus and acknowledge by pressing the key „**5**“ to start „**SUPER-SEARCH**“. Now the rotor will perform a cyclic scan throughout the sky with increasingly wider circles, starting from the point calculated.

It is operating in very small steps (preset **0.1°**). So it will take some time till

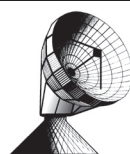



## Supplementary Installation and Operation Instructions

# BI-AXIAL-ANTENNA-ROTOR

anything happens on your TV-screen or testing equipment (you may accelerate this seek-operation by setting the step width under **PRG 32** regarding to the aperture of the antenna, **0.1°** per minute).

The rotor is not able to make any difference between the individual satellites. Under automatic seek it may stop at any wrong satellite. That's why the operator has to do this decision. As soon as there is any acceptable or even recognizable picture on the screen, push „5" again. By this the rotor movement stops and you can test whether this picture really comes from the specific satellite wanted. If not, then start and stop (with key **5**) the further search for the desired program resp. the desired satellite until it was found.

**B.** But you may start a new focus run by pressing the key „0" (zero). Because, however, in this starting phase the adaptation to the different **fieldstrength** levels of different receivers is not completed, probably the result is not as fine as possible. If the result is good and sufficient, store it by pressing key „7". Appearing: „**New ORG POINT**" on the display. Confirm with „E"nter (if you want to correct the settings of this memory only, do not use the „7" but press you „E" for storage).

If you don't succeed with **AUTO-FOCUS**, drive your rotor with keys **2** (EAST/ East), **3** (UP/ upward), **4** (West/ West) and **8** (DOWN/ down) manually onto the best picture and best field strength. If you only want to correct this particular sat-memory, then press „E"nter. If you want, however, to use this „direction" for all the calculations of sat-positions, then push „7" followed by „E"nter.

Switch over to „**R**"UN-modus now and choose any other satellite - and so also the corresponding program at your sat-receiver. If did all the settings correct, have a look now on the selected satellite.

The farther the selected satellite differs locally from the Ref./Norm. satellite (more east - more according to west), the deviations/ errors may increase. These deviations can result out of faulty location coordinates or a slight mast shift to the east or west. This error mentioned last cannot be corrected by the computer. But with the help of the **AUTO-FOCUS-Function** this problem appears to be none for this rotor:

Optimal results of **AUTO-FOCUS** and/or **AUTO-TRACKING** are only achieved, if the AGC-signal shows genuine fieldstrength-originated changes only. The measured field strength from the receiver must match exactly a real certain antenna direction. A wacky, swinging, elastic or even loose connection between antenna and rotor leads rather to the opposite than to a good focussing. Any delay (time shift) of the AGC-signal within the sat-tuner is also causing errors.

The signal coming from the receiver should - as far as possible - refer to the real direction-oriented field strength only, with no other influences. The reception should not show any signals jumps, which are originated by electric influences or „spikes". It should be free of „Image fluctuation" and not influenced by light or dark parts of the television field frame.

**For a good focussing a rigid mechanical connection between antenna and rotor head is a must!**

Now take the **satellite with the strongest signal** (select by front keys or by keys behind the lid). In Europe this will be ASTRA. Do not forget to switch your receiver to this satellite!

Now proceed as shown in chapter „**AGC- matching**".

Some few sat-receivers deliver a reciprocal (inverted) fieldstrength AGC signal. That means: high output signal = low field strength, low voltage = good field strength. In **PRG 19** you can reply the question „**INVERT INPUT-LEVEL Y/N**" in such cases with „Y" (With the key „0" you can switch between „Y" and „N" back and forth).

Other Sat receiver have the peculiarity, that the AGC signal delivers a voltage difference output, i.e: good field strength (Astra) = high voltage = no field strength (no satellite) = medium-sized voltage. In such cases you can adjust the „**Zero Point**" again. After such action please check **ramp/gain** again.

With key „0" you may start again a focus run now.

**Additional Information:** the Autofocus function is provided to optimize already located satellites. These function seeks the greatest possible field strength (level) if already a field strength contact with the satellite is established. Autotracking is to track automatically geostationary, however, inclining (sweeping) satellites. Autofocus and Autotracking aren't designed to seek for satellites. For this purpose, please use the „**SUPER SEARCH**".

For any single optimal focussing followed by a memory-saving, please use - as far as possible - a sat-program with a test picture frame.

In the **RUN**-mode with key „0" (zero) now a single focussing run can be started.

With key „5" (five) you can start the permanent focussing run. Depending on the settings in **PRG 19** after choosing a certain satellite, an automatic single focussing run or a permanent tracking follows (see separate programming list).

With **PRG 19** you can program the „**THRESHOLD**" (signal limit) and the respective „**DELAY**" (time till the next action) for different antenna systems. The „**THRESHOLD**" should be a little bit above the max. level drift when the antenna stands still. To suppress a new focussing run when short bursts or attenuation's occur due to wind gusts, you may determine the delay-time for a new focussing after a signal break-down.

After setting the „**TRESHOLD**" and „**DELAY**" for your convenience or acknowledging by „**ENTER**", some questions are to be answered: do you want the **AGG input signal** to be inverted (**Invert Input Level**)? If your radio or your sat- receiver have a negative AGC output signal, please answer with „Y" for positive.

Do you want a single focussing operation after changing to another satellite (**Autofocus follows Sat select**)? If you answer with „N", you will be asked: Do you prefer automatic or permanent tracking, which means „stick at the signal" (**Autotracking follows sat select**)? You may decide here with „Y" for yes, „N" for no or with „E"nter. (see **PRG 39 FOCUS/TRACK ACTIVITY**)

Depending on the desired operational modus you may set smaller or larger search limit angles with **PRG 20**. To „stick on" drifting geostationary satellites it is recommended to use a smaller search angle. For the fine-optimization of roughly found satellites a larger angle may be useful.

• If the satellite is positioned very close to his neighborhood, a smaller search angle is helpful.

**EGIS** - EQUIPMENT-GESELLSCHAFT für INTERN.  
ELEKTRONIK SYSTEME GmbH

25 minutes from Airport Frankfurt

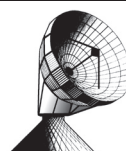

• 25 minutes from Frankfurt City

Flut-Str. 34-36  
D-63071 OFFENBACH/MAIN  
TEL. (++49) 69/858327  
FAX. (++49) 69/857863  
E-Mail: Sat@EGIS.eu  
<http://www.EGIS.eu>

## Supplementary Installation and Operation Instructions

# BI-AXIAL-ANTENNA-ROTOR

- If the best position is outside your preset search angle, the computer assumes, that this is another satellite and will return to his old position. He will not lock on the best signal within his prescribed search angle. He will return to his start position.

For the acceptance of a position decreasing signal levels into all four directions are necessary! The preset value for this search angle is 9,9° the maximum value.

During a focussing run the new position will be only accepted, if a signal difference of at least the size of the engaged „**tresholds**“ is corresponding.

When temporary obstacles in the signal path occur and short-time shadings are caused by flying birds, aircraft's or similar, the system shouldn't focus again immediately. These delay can be determined with **DELAY** beside the **TRASHHOLD** setting.

However, it may sometimes happen, that i.e. a butterfly rests on the **LNB/FEED** and lingers there over a longer period. After the **DELAY** time a new focussing will be performed and then this, very low, field strength signal is the new size for computing.

Because this level is so low, never ever again a lower level will occur after that (but it is a preset for a new focussing operation). Nevertheless, to start a new attempt in order to focus after a certain time again, you may preset -under **PRG 30 (FOCUS INTERVAL)**- a period of time, after which the automatic focussing-run starts again. Available time interval: **0** to **65535** seconds (= **18 h**). Preset at **0** = no automatic attempt.

The movement range (swing) of the system within the mechanical limits can be electronically limited by means of **program memory 21 (PRG 21)** „**LIMIT**“.

In elevation mode the standard-rotor covers a range of **90°**. If you want to limit this deviation, type in **EL = xxx.xx** the corresponding angle. However, it must be below **90°**. The range always counts from the **ORG point** (elevation starting at the lower swing limitation).

If the unit is equipped with a mechanical **90°** head, you have to inform the control unit using **PRG 22 „ROTOR TYPE**“. Another angle scale will be internally calculated and the indication corrected. (**90°** head users should adjust, if necessary, the elevation **ORG point** at „**0**“ or less in **PRG 02**).

In Azimuth the standard rotor performs a turn of **300°**, in the compass sectors of **30 to 330°**.

If the range is too wide, the given degree figure always counts from the **ORG point** (see **PRG 02**, preset is **30°**), i.e. given 123.64; means: moving range **from 30° to 123.64°**.

If you type in [with a 360° rotor] **360.00**, the motor is allowed to turn accurate **360° from the ORG Point**.

For any operation that shall **exceed 360°**, fine-step limitations, which use figures right from the comma, are not available. These two digits then operate with another function:

The two digits right from the comma determine the permissible number of complete Azimuth revolutions, i.e. **360.01** means, that the rotor head, be-

ginning from the engaged **ORG point**, can absolve a whole revolution in plus direction and a whole revolution in minus direction: **+/- 1** revolution.

If you set here i.e. „**03**“, the rotor performs **6** revolutions totally. Maximum are **+/- 99** revolutions, the setting in this case would be **360.99**.

If the rotor is engaged over these limits whilst searching a position of a satellite or during the „**Permanent Focussing Operation**“, this is once possible **up to 180°!** Will, however, a further positioning exceed this position, the rotor will run, automatically, a whole revolution back and sojourns to the desired position (the figure of the turn-counter can be seen in **PRG 92**)

If you attempt to move into the „forbidden“ area within the „**T**“ch mode by pushing a key, the motor is subsequently stopped at the „border“. The operator must drive back to the desired position by hands - push by push.

The „**LIMIT**“ function additionally serves to drive back the rotor-head in conjunction with the start of an **ORG-run**. If i.e. the rotor-head made several revolutions into the same rotary direction, after a certain time, a dangerous condition may occur. The antenna connection cable could be torn off. With **ORG** setting of larger than 360.00 and at the start of a **ORG-RUN** with key „**9**“ (only in the Teach Mode) the rotor turns back automatically all revolutions made before and orients itself exactly at the internal **ORG switch** in the last turn.

If „**LIMIT**“ is set smaller or exactly to **360.00** (i.e. **290.00**), after an **ORG** start the rotor will seek for the **ORG point** in this turn only. The **rotation-counter** will be set to „**0**“. If via **PRG 34** an „**ORG RUN suppression**“ is programmed, spool-back will **not** be originated. If the operator wants to rewind the rotor head, he has to do this manually using the keys.

### AZ-ROTATIONS (PRG 92)

This program memory allows to display and to modify the **360° rotation-counter**. The meaning of i.e. „**E002**“ is: rotor moved two turns east from the **ORG point**. „**W001**“ means: rotor moved one turn west from the **ORG point**. By overwriting this value other positions can be programmed - within the guidelines given under **program memory 21**.

The rotor version with a turn range of 360° allows to control/manage up to 99 azimuthal turns. The **valid amount of turns** can be pre-programmed in **PRG 21**. The **current** state of the rotor-head turns is shown in **PRG 92**.

This internal **AZ turn counter (PRG 92)** has his own RAM memory location, which can not be deleted by a „**RAM check**“ and/or re-loading the firmware into the main memory.

This is an attempt to save the rotors' position; even after booting with a new software.

By this an erratic status may occur unfortunately, e.g. after a control unit change or a firmware upgrade. In such cases the firmware notifies:

### “ROTATION ERROR !!! CHECK AZ-TURNS”

The operating system has detected a mismatch between the programmed limited amount of head turns, the value in the internal rotation-counter and the actual reserve of feeder cable-length (RF or LNB switching cable).



- EQUIPMENT-GESELLSCHAFT für INTERN.  
ELEKTRONIK SYSTEME GmbH

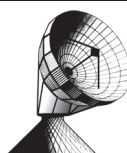

Flut-Str. 34-36  
D-63071 OFFENBACH/MAIN  
TEL. (+49) 69/858327  
FAX. (+49) 69/857863  
E-Mail: Sat@EGIS.eu  
<http://www.EGIS.eu>

25 minutes from Airport Frankfurt

• 25 minutes from Frankfurt City

## Supplementary Installation and Operation Instructions

# BI-AXIAL-ANTENNA-ROTOR

In this case you should synchronize the value in the internal rotation-counter in **PRG 92** with the cable reserve (turns around the shaft). Use **PRG 92** to perform this. Overwriting the preset values erases the information about an error and the system will be unlocked for normal operation.

### ORG point shift (PRG 02)

This memory shows the shift of the ORG point (**Point of Origin = reference point in the housing**) in degrees, in azimuth values related to „NORTH“ and in the elevation, related to surface of the earth (horizon/horizontal). There will be displayed **30°** for AZ and **0°** normally for EL.

This reference point can be altered by overwriting the old values. If i.e. „true NORTH“ is situated **5°** west from the northern mark on the housing, then you have to type in the added values  $(30+5) = 35°$  instead of **30°**. The internal computer reads: the „true NORTH“ has a shift (deviation) of **5°** from the internal **ORG switch!**

Using the automatic correction with help of the key „7“ in „T“ch mode, the corrected value in **PRG 02** is calculated automatically and will be registered in **PRG 02** (see ORG Run).

### ORG RUN SUPPRESSION (PRG 34)

With each system start (also caused by a fault or power failure during a positioner action or after any new installation) the control electronics demands an ORG run. That means, the AZ-motor turns the rotor head precisely into the eastern direction. In the EL-axis the rotor turns into the lowermost possible position. There the rotor refers to a switch and turns into the desired position after that.

If you don't want this procedure to be performed, (i.e. because there is not enough free space for the whole movement-swing of the antenna) you may suppress this operation. For this you have to perform the following steps: turn the rotor with the keys 3/ UP 8/ DOWN 2/ EAST 4/ West **PRG 98** or; if necessary, in „T“ch mode onto the position **AZ = about 180°** and **EL = about 30°**. Pay attention on the rotor and drive into these positions. That mustn't be done very precisely.

Then type in the password „2288“ in **PRG 34** and acknowledge with „E“nter. Take a high as possible positioned satellite in the „R“un mode and search in „T“ch mode, then align fine if necessary. End with „7“ and „E“nter. Under „R“un take any satellite, tune fine if necessary and save with „E“nter.

### Special command:

If there is requested a position via the serial Interface **RS232C (extension DATA)** from the control unit, the respective up-to-date position-data appear. If the rotor is engaged at this moment in a focussing-operation, the actual queuing position will be given out in fractions of seconds - possibly left or right and above or below related to the focus point. With the new command **&\* focus RESULT=1 (CR)** the rotor only is caused to output the results of one focussing run - always at the end of a of a run. This command causes the automatic repetition of this output after each focussing additionally. By this it is not necessary to start the request each time again.

After each focussing you will get - without request - the azimuth and elevation-position and the relative field strength belonging to them. (The field strength signal is only available in equipment with AGC-input). This feature is provided for the documentation of focussing operations. In the external computer you have only - ingeniously - to add the date and time of the day to the data string and you will get the exact information belonging to the „tracking behaviour“. This mode can be switched off with the command **&\* focus RESULT=0 (CR)**.

This command can be entered also via **program memory 31 (PRG31)**. Then you can feed the results directly into a printer, a control station or a supervisory panel, you do not have to use a computer for this.

**Only with actions induced by commands coming in via the data interface an error message appears via the data interface.**

This enables the „motor-override-action“. This function last mentioned allows to operate the motor independently from the equipment modus or feedback. The motors will thereby not watched by the electronics and may, carelessly used, burn out! So only use this in emergency.

### Direct Angle Access

Such as already discussed, satellites can be dialed via the two exterior front keys or in direct-access, via the numeric keyboard under the lid.

For that you have to start with „E“nter in the „R“UN modus. After that type in the **Sat-No.** The satellite will be targeted. However; if you press „E“nter twice, the cursor shifts onto the momentary **AZ angle**. There you can now input directly an **AZ angle** - and the rotor will automatically position itself on this AZ angle. If you push three times „E“nter; you can drive directly onto the desired EL angle.



- EQUIPMENT-GESELLSCHAFT für INTERN.  
ELEKTRONIK SYSTEME GmbH

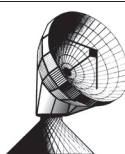

Flut-Str. 34-36  
D-63071 OFFENBACH/MAIN  
TEL. (++49) 69/858327  
FAX. (++49) 69/857863  
E-Mail: Sat@EGIS.eu  
<http://www.EGIS.eu>

25 minutes from Airport Frankfurt • 25 minutes from Frankfurt City

## Supplementary Installation and Operation Instructions

# BI-AXIAL-ANTENNA-ROTOR

### Matching the AGC

Serves to match the **AGC signal** from the sat-receiver/Radio/Scanner to the AGC input in the rotor controller. There are two tuning features: **offset/zero (ZERO)** and **gain/ramp (GAIN)**. This tuning can be managed from the front keyboard in program mode **PRG 93 (AGC ADJUST)**.

#### Procedure:

- Set offset to zero (**ZERO**) first
- To perform this, at first drive the rotor to any position in "T"CH-mode up to a point, where no signal appears. (Best out of „Clark-belt“ a satellite belt around the equator).
- Select **PRG 93 (AGC ADJUST)**
- The actual **AGC-level** will be displayed whole right as a three digit figure (**LEVEL**, operating and display range **0-254**). Using keys **1** and **6** match to value near **000**, but not below. **001 - 005** will be good (little bit more than **natural AGC-level drift**). Save with „E“nter. (The three digit value beneath **ZERO-display** is to show the correction value and not of importance here.)
- Now set signal ramp and gain (**GAIN**).

• Drive rotor in „R“un or „T“CH mode to the strongest expectable satellite/radio/scanner signal. In western Europe this is ASTRA normally. (When you are using different **LNBs** the strongest signal may appear from another source. Test it out! Then optimize in „T“CH mode once again for **best results**.

**Please note: transponders on same satellite often transmit with different power.**

- After that select **PRG93** again
- Using keys „2“ and „7“ trim three digit level display to show approx. **200**. Save with „E“nter.
- The three digit readout beneath the „GAIN“ display is not of any importance, it is only to mark the correction value.
- The „zero setting“ may be influenced. So please repeat setting „zero“.
- For this „position“ rotor in „T“CH mode into a situation, where no signal appears (best above out of clark belt)
- Select **PRG 93 (AGC adjust)**
- Using keys „1“ and „8“ set level value slightly above zero readout (**001** to **003** will be good and slightly more than the inherent **AGC drift**) Save with „E“nter.

- In the „R“un mode only the strongest satellite should be used. You may start a focussing run by pushing the key „0“ (**zero**).

- If the level display exceeds **245** and is bouncing the upper end, the **ramp/gain** should be reduced with **PRG 93**, using the keys **2** and **7** again to reduce the reading down to about **220** to **230**.

With the factory preset you can utilize **voltages** from **0 V** up to approx. **12 V** (resp. level displayed **0 - 254**). Should the level exceed **245** after optimizing later on, please reduce „GAIN“ slightly to allow the control to have some room up to a maximum of **254**. By this you can utilize voltage drifts down to **0.1 V** for **autofocus**.

### Testing the AGC input

Set „ZERO“ and „GAIN“ to „000“ in **PRG 93**. Then connect a **9 V block battery** to the input. The display now should show a **LEVEL** in the area **170-210**. If you like to use a single cell battery, you should get a readout of **29-34**. This voltage span might come (for instance) out of your receiver. Then you would allocate the lower voltage to „ZERO“ (no satellite). In this case the „GAIN“ has to be tuned to a value of approx. **220** with the **9 volts** applied (strong satellite signal).

One more test: „ZERO“ = „000“ and „GAIN“ = „254“. LEVEL should display **250** now, when **250 mV** applied.

#### Hint:

Any sat-receiver needs an AGC signal internally. That voltage can be made accessible for the rotor-control with only few electronic affords, if not available on a connector: **EGIS** has modification proposals for some sat-receivers.

One more way to get a field strength signal out for the rotor, is to use a **sat-finder**. You simply have to take out the voltage normally needed by the instrument and to feed it into the **AGC-input** of rotor control box.

Best results you will have with a **EGIS-SpectraMizer**. This device is made specially for this task!

If you never want to use externally calculated positions/angles you do not need to read the following part and you may skip this.

Resulting out of a linear movement the movement of the **90-degrees head** (elevation) is determined by two coupled gears/curves. That is causing non-linear errors (resulting out of tolerances) over the whole travel from **0 to 90°**. These errors are not correctable in any case and at any point. However, you may calibrate on one certain point to work very precisely in a limited angle of elevation at last. This matching has to be found empirically by try and error.

If you recognize, that the rotor is positioning too low at this desired point, you have to lower the values preset in **PRG 94** if appropriate (these are motor pulses). If the rotor targets above the point, these values are to be increased. After each change enter the „T“each-mode and start an **ORG-RUN** with key „9“.

However, caused by these measures greater errors may occur on other positions. During „daily work“ with these rotors you will want to store a certain position immediately in the memory sometimes, when you have found an interesting point/target/direction/satellite. This is no problem. Switch first into the „T“each mode (if you are not in this mode already). With keys „1“ (**higher/upward**) and „2“ (**lower/down**) „scan“ the possible memories and select one of them. Then store with „E“nter. The original data at this new memory place is lost.

### TARGET CHAIN (PRG 37)

After **confirming** this program memory the rotor will scan automatically, from east to west, all satellites in sight. The delay-time on each found satellite position can be pre-determined. Input-values are in seconds.

Beside single satellite applications there is the possibility for the specialized trade with this option, to show the rotor in permanent motion and draw attentive at this product.



- EQUIPMENT-GESELLSCHAFT für INTERN.  
ELEKTRONIK SYSTEME GmbH

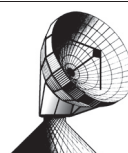

Flut-Str. 34-36  
D-63071 OFFENBACH/MAIN  
TEL. (++49) 69/858327  
FAX. (++49) 69/857863  
E-Mail: Sat@EGIS.eu  
<http://www.EGIS.eu>

25 minutes from Airport Frankfurt • 25 minutes from Frankfurt City

## Supplementary Installation and Operation Instructions

# BI-AXIAL-ANTENNA-ROTOR

### Comments to PRG 98 (MOTOR TEST):

Within this you will find the information about the switch-positions of the ref. switches (**ORG-switches**) in the rotor housing. For a test (**Azimuth**) drive the rotor head, using key **4** (West), a little bit westbound and with the key **2** (EAST) back again till the eastern end. Short before the total end of the turn or at **90°** east, the switch symbol must change from open to close. In the display **-/-** means open switch and **-+** closed switch.

By pushing the keys **3 (UP) / 8 (DOWN) / 2 (EAST) / 4 (WEST)**, you can get information belonging to the functions of the internal motor-incremental-sensors. If the three-figure digital counter figures change during operation, the correct function of the motors and the sensors is to be assumed (the figures themselves have no meaning).

If the control unit detects any error, it stops operating and asks the user for the password „**3377**“.

This enables the „**motor-override-action**“. This function last mentioned allows to operate the motor independently from the equipment modus or feedback. The motors will thereby not watched by the electronics and may, carelessly used, burn out! So only use this in emergency.

It may happen you will find a problem like this: The rotor with his control unit is not working any more and on the display appears:

**AZ ORIGIN NOT FOUND**  
or  
**EL ORIGIN NOT FOUND.**

The information about an error as mentioned above occurs with head positions all in the east and/or at a very small **EL angle**. This means: Orientation switches of the rotor for the azimuth or the elevations axis are not found. These **two ORG switches** are mechanical micro click-switches, which have open contacts in unengaged state. They are closed only in exact eastern head position (AZ) and for EL only in lowest position. These two switches will be needed only during the **ORG-RUN** and in normal operation never ever again.

During installation or after special actions or counting uncertainties the rotor requires an orientation run. During this **ORG-RUN** the rotor ori-ents itself within the cabinet. It is driving into the eastern direction (**90°**) onto the switch mentioned before (**ORG switch**) and after that onto the lowermost possible elevation position (**flat via the horizon**), where an ORG-switch operates too. After that the control unit knows at which loca-tion the rotor head is within the cabinet.

If these switches are not found by this action, the error messages shown above appear in the display. Technical reasons for these errors can be a loose, broken wire between rotor and control unit or, of cause, a defective ORG switch.

In **PRG 98 (MOTOR TEST)** you may activate the motors without a preceding **ORG-RUN**. Thereby you may check two functional groups: the reference/orientation switches of each axis (**A**) or the feedback-pulse check for each axis (**B**).

**A)** Thereby you can check, if the reference switch information reaches the control (shown in the display with switch symbols). For a test (azimuth) drive the rotor-head slight westbound with key **4** (west) and with key **2** (east) back again all east. Short before the total end of the turn the the „**open**“ switch symbol has to alter to „**close**“. To unengage the switch drive a little east if appropriate.

For an elevation-test drive upwards first (key **3/UP**) and then once again down (key **8/DOWN**) to the total end of the movement range. Also watch the symbol showing a closed switch and an open switch when driven back higher:

If you are using the version „**ProfiTracker with Motion-Control**“ dur-ing these measures mentioned above, the motors will run at high speed. Test the correct switching into low speed operation by pressing key **“0”** (zero).

If any problem should occur, check the interconnect wires with an ohm-meter or a multimeter if appropriate.

Both switches have one common wire: **pin 12** of the connection between rotor and control unit. The switch output for **AZ** is the no. **10**, for **EL** the no. **9** (see rear side of the control unit). Disconnect the wires from the control unit before you attempt to take measurements - and then measure from the free wire strips. After that you should check the rotor contacts (the respective wires leading to the control unit are to be disconnected, too).

If one of the switches is really faulty, it can be repaired/ replaced easily by an engineer without soldering. But the rotor has to be dismantled!

For equipment with firmware-version up from V7020 and newer there is an alternative: The **ORG-RUN** can be suppressed in **PRG 34**. The rotors behavior then is determined mathematically only. No **ORG-RUN** is performed.

**B)** Feedback pulse check with integrated pulse transmitters on each motor axis, displayed as 3-digit counter value.

If the control-unit shows an error message during this operation, the mo-tors can be emergency-operated by typing in the password „**3377**“. Be careful! The motors are not supervised and can be damaged if blocked for a longer period of time!

For an independent moving test of the rotor (the control unit is not involved) you may feed the motors directly **via an external DC power supply**.

### Azimuth motor:

Disconnect the wires 17 + 18 from the control unit. Measure the resis-tance of the motor coil with an ohmmeter. That should not be below 5 Ohms and not more than 50 Ohms. Apply a voltage between 12 to 24 V onto these wires now. The max. power dissipation should be approx. 2.5 Amp. (normally about 0.8 Amp.). With the polarity + (plus) at 17 and (minus) at 18 the rotor turns to west (plan view clockwise).

### Elevation motor:

Disconnect wires 15 + 16 from the control unit. The coil resistance can be measured with an ohmmeter now. You should get a reading not below 5 Ohms and not more than 50 Ohms. Apply a voltage between 12 to 24 V to these wires. The max. power dissipation should be 2.5 Amp. (normally about 0.8 Amp.). The rotor head is moving upwards with the polarity + (plus) at 15 and - (minus) at 16.



- EQUIPMENT-GESELLSCHAFT für INTERN.  
ELEKTRONIK SYSTEME GmbH

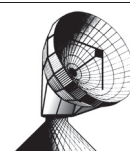

Flut-Str. 34-36  
D-63071 OFFENBACH/MAIN  
TEL. (++49) 69/858327  
FAX. (++49) 69/857863  
E-Mail: Sat@EGIS.eu  
http://www.EGIS.eu

25 minutes from Airport Frankfurt • 25 minutes from Frankfurt City

## Supplementary Installation and Operation Instructions

# BI-AXIAL-ANTENNA-ROTOR

### FOCUS/TRACK ACTIVITY (PRG 39)

In this program-memory you may determine, on which satellite a focussing operation is performed only once and on which one this is done permanently onto the best signal or on which one you will get only a simple positioning. Use keys "2" and "4" to decide between focussing or tracking. Use keys "1" and "6" to switch between the satellites and then decide "Y" es or "N" o. Save with "E"nter. (see PRG 19)

### GPS CAPTURE FUNCTION (PRG 42)

In this program-memory you may take over global positioning data automatically from a **GPS navigator/receiver** via the serial interface into program-memory PRG 01 of the control-unit.

Description of the **GPS interface** and the protocol used:

The **GPS navigator/receiver** has to be connected via the **RS232 interface** at the rear side of the control-unit. The adoption to **4800 baud 8N1 (8 bit/no parity)** is performed automatically.

The **NMEA183** protocol with data set "**GPRMC**" will be used.

How to handle: Select **PRG 42**. Wait a short time till a valid data packet can be read from the **GPS** equipment. The cursor in the control-unit will jump back and a new PRG function can be selected. After that it is recommended to go to **PRG 01** and to initiate a new angle-calculation.

### DISPLAY ANALOG CH. (PRG 47)

Hereby you may determine the analog-channel to be displayed. The display shows a 8-bit word (3 digits): "0" no value to be displayed;

"1" analog input display (analog jack), marked as "A"

"2" not used (till now)

"3" internal backup-battery voltage display (marked "C")

"4" motor power supply (marked "D")

"5" wind speed display (shows wind speed instead of an analog value)

"Wxxx" instead of an channel marker,

"W" represents wind.

### SUN WARNING (PRG 50)

This function protects the LNB against overheating or damage caused by the radiation of the sun. Ever the sun, the satellite and the antenna are lined up on one common axis, the heat-radiation of the sun can be concentrated onto the LNB and may cause a degradation or destruction. This event can happen twice a day. Especially LNB's with a low noise figure are critical in their margin to the temperature-originated noise. It may happen, that the signal-quality goes down dramatically, till the unit cools down. The heat-up/cool-down time can be minimized, if you are using the **built-in alarm-functions** and react appropriate.

With these functions you get an early warning, before any dangerous situation occurs. Premise to the save use of this function is a correctly mounted antenna and a correct setting of the local values (PRG 01) and the date/time in PRG 52 (must be in UT!).

Implemented in the control unit, an **astronomical calculation-program** using **Kepler-data** of earth and sun checks the sat-position for any such collision.

If the warn-mode is activated, a buzzer warns the user whenever the warning-limits are exceeded. You may also induce a swing-out **automatically**.

This function is activated in **SUN WARNING (PRG 50)**:

0 = off

1 = buzzer

2 = automatic swing-out

3 = buzzer and automatic swing-out

The actual sun position can be watched in **SUN POSITION (PRG 51)**.

The safety-angle for the warning can be set in **WARN TIME (PRG 53)**, the increments represent the time before the sun reaches the focus and a **warning/swing-out** is performed.

In **WARN ANGLE (PRG 54)** you may preset the **warning-angle in angle-degrees**, before the sun reaches the focus and a warning/swing-out is performed.

### PRG LOCK (PRG 33)

The **19"-Rack -Controller** -Version possesses an integrated **security lock** with key. Using this key, **program functions (PRG)** can be locked against unauthorized operation or access.

Key in upright position = free operation

Key in horizontal position = PRG functions locked

To activate this function, the following measures have to be taken:

Dial up **PRG 33: PRG LOCK** and „E"nter

Enter password: **5545** and „E"nter

Now **'PRG LOCK N'** will appear on the display. The position of the cursor is 'N'. Press the key '0' (zero) to switch to 'Y' and „E"nter:

The display now says: **,LOCKED IF CONTACT CLOSED N'**. The position of the cursor is 'N'. Press the key '0' (zero) to switch to 'Y' and „E"nter:

Now the **mechanical lock** can be used to lock and unlock operations.



- EQUIPMENT-GESELLSCHAFT für INTERN.  
ELEKTRONIK SYSTEME GmbH

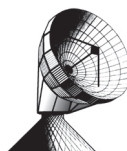

Flut-Str. 34-36  
D-63071 OFFENBACH/MAIN  
TEL. (++49) 69/858327  
FAX. (++49) 69/857863  
E-Mail: [Sat@EGIS.eu](mailto:Sat@EGIS.eu)  
<http://www.EGIS.eu>

25 minutes from Airport Frankfurt • 25 minutes from Frankfurt City

# BI-AXIAL-ANTENNA-ROTOR

## CONTROL UNIT DISPLAY CONFIGURATION

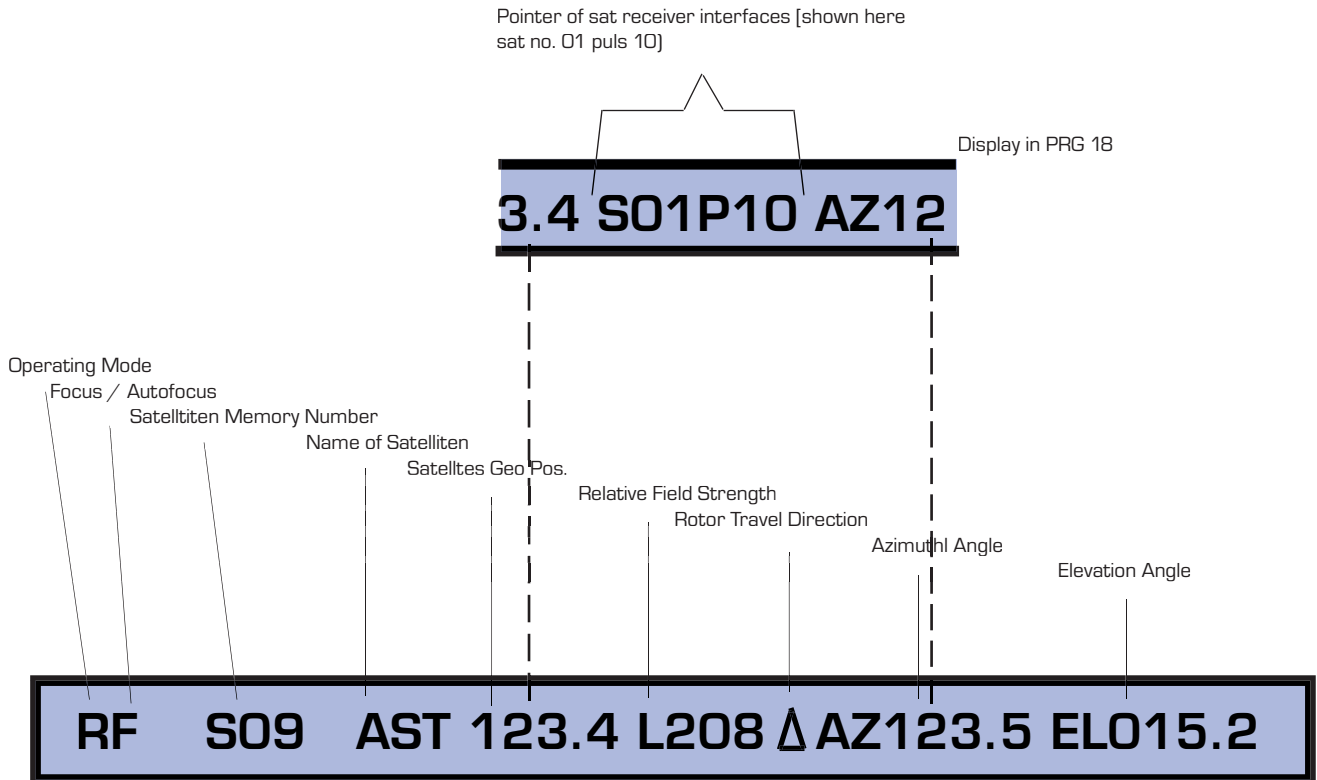

Attention: Not all of these functions are available in all versions and operating modes.



- EQUIPMENT-GESELLSCHAFT für INTERN.  
ELEKTRONIK SYSTEME GmbH

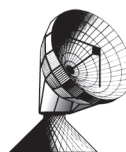

Flut-Str. 34-36  
D-63071 OFFENBACH/MAIN  
TEL. (++49) 69/858327  
FAX. (++49) 69/857863  
E-Mail: Sat@EGIS.eu  
<http://www.EGIS.eu>

25 minutes from Airport Frankfurt • 25 minutes from Frankfurt City

## Supplementary Installation and Operation Instructions

# BI-AXIAL-ANTENNA-ROTOR

### ANALOG INPUT SOCKET CONTACT ASSIGNMENT: FIELD STRENGTH (AGC)

[Location: approx. center of cabinet rear panel  
Contact assignemnt according to DIN 45 929]

Ground for contact 1, 2, 4 & 7 (normally not used)

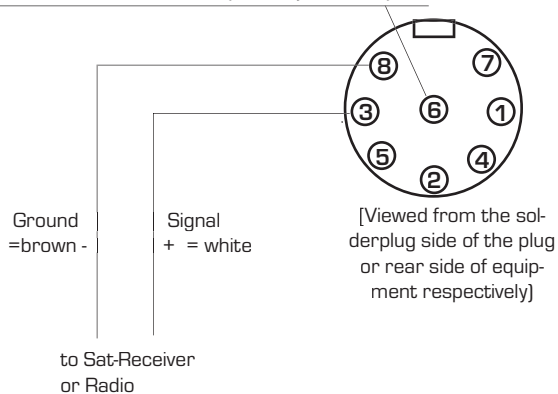

pin	signal/function
1	= logig level input
2	= analog ch.3 input (0 bis 5 V)
3	= analog ch.1 ( <b>AGC</b> ) (0 bis 12 V)
4	= analog ch.2
5	= +12 V (max. 10 mA)
6	= ground for conector 1, 2, 4 & 7
7	= logig level input
8	= ground for conector 3 & 5

Kontakt 3, 5 & 8 physically separated!

Use the cable enclosed. Because normally the Sat-Receiver is standing direct besides the controller, the AGC cable should not longer as the given one.

Please notice: In some cases producer of the plug-connectors have their own number system - pins can have other numbers! But the "2-wire-cable" given with our rotor are correct. We know this can be confusing!

For longer distance between the AGC source device and the EGIS-controller use a shielded cable system as follow:

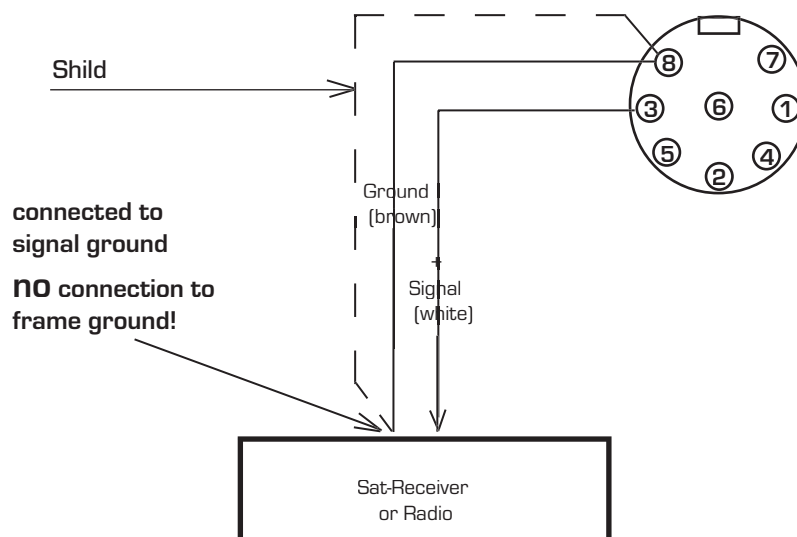

- EQUIPMENT-GESELLSCHAFT für INTERN.  
ELEKTRONIK SYSTEME GmbH

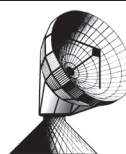

Flut-Str. 34-36  
D-63071 OFFENBACH/MAIN  
TEL. (++49) 69/858327  
FAX. (++49) 69/857863  
E-Mail: [Sat@EGIS.eu](mailto:Sat@EGIS.eu)  
<http://www.EGIS.eu>

25 minutes from Airport Frankfurt • 25 minutes from Frankfurt City



Only one of the two control-options described subsequent can be used via the '4-wire interface': the 'wind sensor function' or 'motor pulse receiver control'. In PRG 40 select the function.

According to application of the interface following hardware change is to be undertaken:

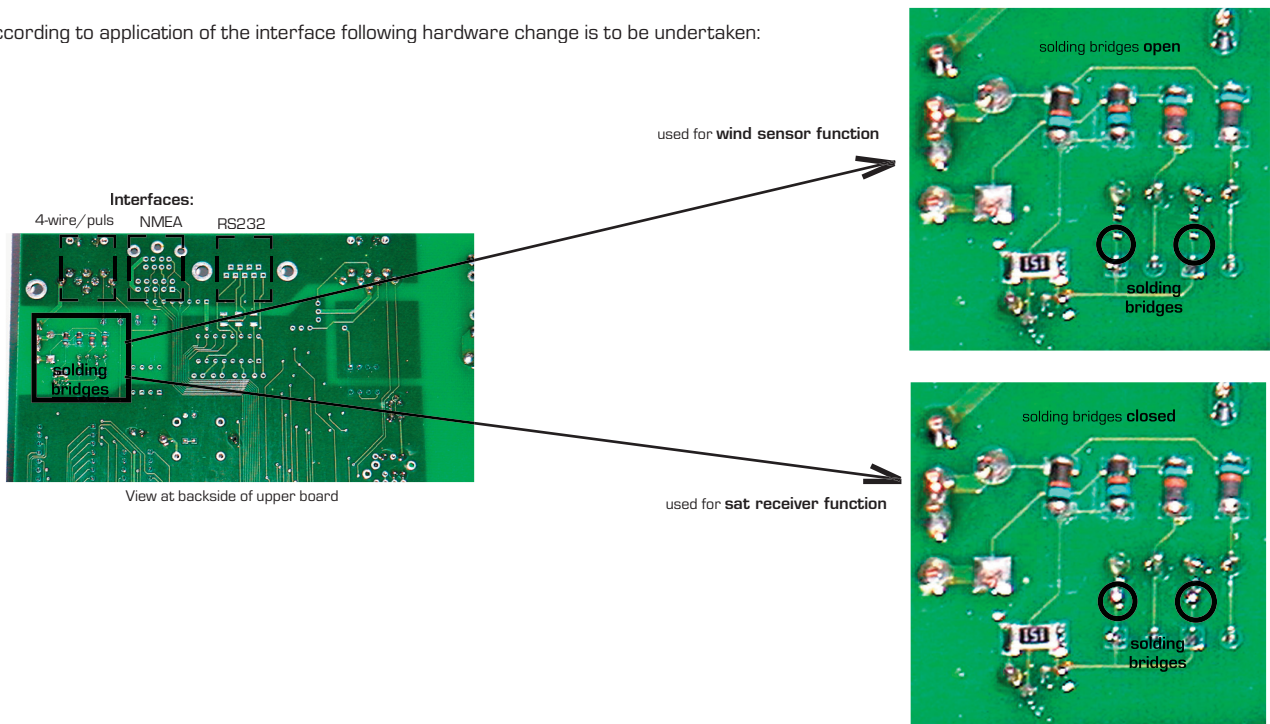

## WIND-SENSOR INTERFACE

[2-wire connection via 4-wire pulse interface]

When the wind-speed exceeds a preset value, an automatic drive onto a programmable rotor-position is performed.

**Premise:**

The control unit has to be switched on and operated in the mode "R"un oder "T"ch. The unit should have accomplished an **ORG-run** successfully.

**Behavior:**

Whenever the pre-programmed wind-speed is reached, the display will show "WIND\_LOCKOUT WIND=xxx km/h WAIT= xxx min". This shows, that the wind warning is active.

Now drive the rotor onto the positions determined by the user. Additionally the display shows the respective remaining time till switching back into normal operation (increments in minutes remaining).

If the wind speeds up during this time again exceeding the preset value, the runtime starts again.

**PRG 40:**

Defines the respective function of the 4-wire jack on the rear side of the unit:

- A) '4-wire pulse interface' to control a 'satellite receiver positioner' or
- B) to use a 'wind speed sensor'.

This serves to match the control with the wind speed sensor used and to activate the wind lockout function.

1. Displayed in the first window "WIND SENSOR METER/IMPULSE =x,xx" "0.00" or can be preset here, showing that the 'sat receiver

function' is active (default value: 0.00). No further input windows are appearing. Conclude settings with "E"nter.

2. Display showing: "WIND SENSOR METER/IMPULSE=x,xx". This shows the wind-speed limit in meters/second to get one pulse out of the wind-sensor (ratio pulse/path). If the display shows '0.00' the wind lockout function is inactive, no other input-windows will appear.
3. Display showing: "WIND SURVIVAL POS AZ=xx". Default is AZ=180 degrees, EL= 40 degrees. Hereby you may determine the "survival-position". This position will be checked and values outside the limits (PRG 21) are not accepted. If the rotor is mounted "hanging" the EL values are interpreted as negative values.
4. Display showing: "WIND THRESHOLD=xxx km/h". Default: 50. Determination of the activation-threshold. If the wind speeds up to this value or above, the rotor drives onto the "survival position (PRG 40/3)
5. Display showing: "WIND RETURN DELAY=xxx MINUTES". Default: 30. This determines the time delay within the "wind survival position" after the wind has got calm. (PRG 40/4).



- EQUIPMENT-GESELLSCHAFT für INTERN. ELEKTRONIK SYSTEME GmbH

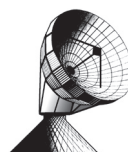

Flut-Str. 34-36  
D-63071 OFFENBACH/MAIN  
TEL. (++49) 69/858327  
FAX. (++49) 69/857863  
E-Mail: Sat@EGIS.eu  
http://www.EGIS.eu

25 minutes from Airport Frankfurt • 25 minutes from Frankfurt City

# Supplementary Installation and Operation Instructions

## BI-AXIAL-ANTENNA-ROTOR

### PRG 91 (WIND-SENSOR-TEST):

This serves to check the wind-sensor-interface.

#### 1. Window:

Display showing: „PRG 91 WIND-SENSOR-TEST xxx km/h | |”.

Default: „Switch-Symbol opened“[ / ].

Shown are the wind speed (provided that the ratio pulse/path was specified in PRG 40/01) and the sensors' switch settings;

Separately for positive or negative approach (if current flows, the symbol shows a switch closed, if else, an open switch).

Additionally the integrated **buzzer sounds** at current flow, to make perceptible also short quick pulses, not to be seen in the display.

For an **enhanced test** the ongoing top-level wind speeds can be read in

PRG 91. Then switch to **PRG 40** and press the „E”nter-key until the display shows: „WIND THRESHOLD=xxx km/h”. Now you must enter a wind-speed value, which is slightly below the top-level wind speed you read out before. Close with „E”nter: After this, switch to „R”UN-Mode.

As soon as the now programmed top-level-value for wind speeds is exceeded, the system will move into the programmed rotor-**WIND SURVIVAL**- position.

Once the test has been carried out successfully, the original threshold level has to be entered again in **PRG 40**.

This interface can be found rear on the control unit, straight left seen from behind.

### Connection and pin-out:

Connection:

Wind keying voltage: 24 VDC (9 to 50 V), about 940 Ohms

Keying frequency: max. 100 Hz

Input/Output galvanically separated

Jack: 8pin DIN type Hirschmann MABSSH

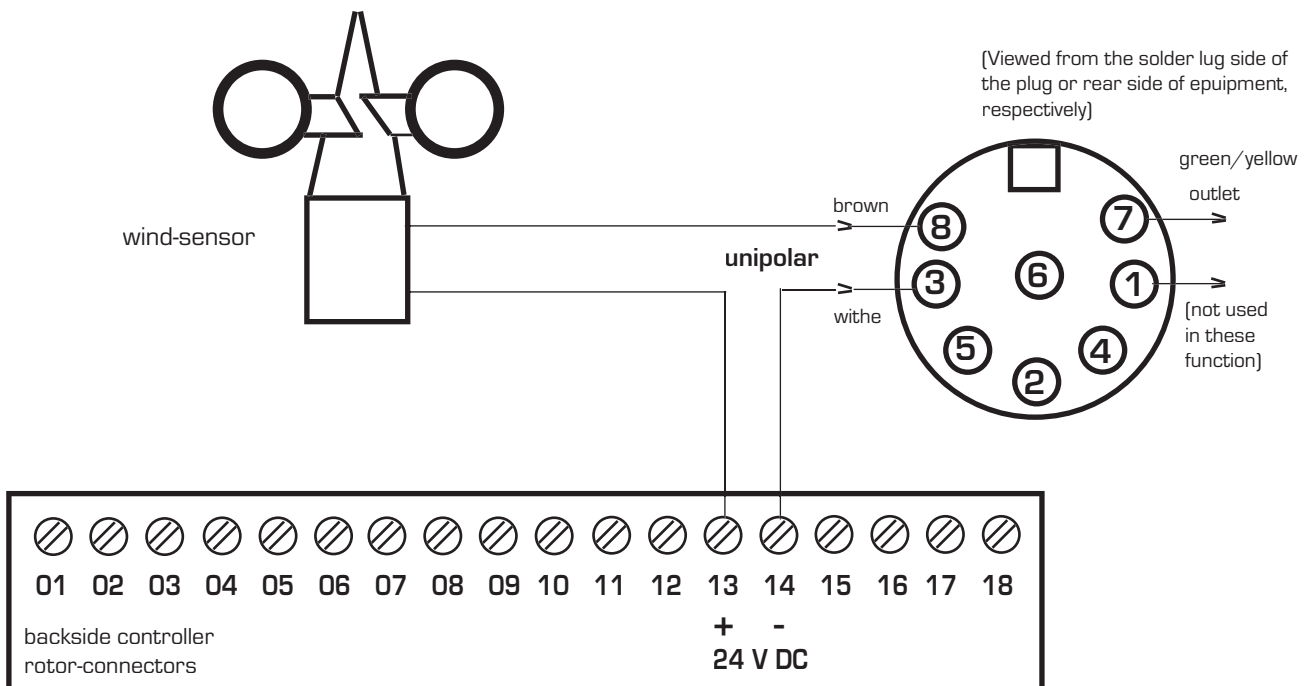

- EQUIPMENT-GESELLSCHAFT für INTERN.  
ELEKTRONIK SYSTEME GmbH

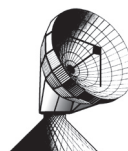

Flut-Str. 34-36  
D-63071 OFFENBACH/MAIN  
TEL. (++49) 69/858327  
FAX. (++49) 69/857863  
E-Mail: Sat@EGIS.eu  
<http://www.EGIS.eu>

25 minutes from Airport Frankfurt • 25 minutes from Frankfurt City

## Kurz-Bedienungs-Anleitung für SATELLITEN-RECEIVER-INTERFACE (4-Draht-Verbindung)

- EGIS-Zwei-Achs-Rotor fertig installieren und aufbauen, so daß an den Fronttasten des EGIS-Steuergerätes sicher und zielgenau Satelliten angewählt werden können.
- Ggf. die Auto-Focus-Funktion an Ihrem Sat-Receiver abstellen.
- Das mitgelieferte 4-Draht-Kabel an den Motor-Ausgang/Puls-Eingang des Sat-Receiver's anschließen (siehe Skizze auf der nächsten Seite) und in „Motor-Puls“-Buchse am EGIS-Steuergerät stecken.
- PRG 18 anwählen und 2x „E“nter drücken.
- Schiebeshalter auf „R“un stellen und mit den Fronttasten den Satelliten anwählen, der auf Ihrem Sat-Receiver eingestellt ist. In der Mitte des EGIS-Displays ist S01 P00 zu sehen. Der Sat-Receiver-Pointer/Zeiger steht auf dem ersten Satelliten der EGIS-Sat-Liste.
- Unter PRG 97 mit OST (2) und WEST (4) Taste auf den, am Sat-Receiver eingestellten Satelliten einstellen (die Nr. ist der beigefügten EGIS-Sat-Liste zu entnehmen).
- Am *Sat-Receiver* kann diese Position als erster Satellit *abgespeichert* werden.
- Falls der Sat-Receiver jedoch verlangt, daß vorher das Ost- und West-Limit abgespeichert werden muß, schauen Sie in die Mitte des EGIS-Displays und fahren - *über Ihren Sat-Receiver bedient* - auf die Sat-Nr. eines sehr östlich liegenden Satelliten und speichern diese Position als Ost-Limit, *auf Ihren Sat-Receiver*, ab. Dann fahren Sie - *über Ihren Sat-Receiver bedient* - auf die Sat-Nr. eines sehr westlich liegenden Satelliten und speichern diese Position als West-Limit ab.
- Zeigt der Receiver Motor-Fehler an oder läuft die Anzeige im EGIS Display in die falsche Richtung, müssen die beiden Drähte, die an die Motor-Klemmen des Sat-Receiver's führen, vertauscht werden.
- Danach wählen Sie, über Ihren Sat-Receiver, einen anderen Satelliten an. Der Pointer/Zeiger im EGIS-Display zeigt auf einen falschen Satelliten. Fahren sie nun - *über Ihr Sat-Receiver bedient* - die richtige Sat-Nr. (entnommen der EGIS-Sat-Liste) an. Dabei schauen Sie immer auf das EGIS-Display. Es könnte jetzt z.B. S50 P08 erscheinen.
- Jeweils ca.1 Sekunde nach dem Sie die *Bedienungs-Tasten Ihres Sat-Receiver's* los gelassen haben, beginnt der Rotor zu drehen und nimmt die entsprechende Position ein.
- Wählen Sie nun, *über Ihren Sat-Receiver*, einen anderen Satelliten an. Der Pointer/Zeiger im EGIS-Display zeigt noch auf einen falschen Satelliten. Fahren sie nun - *über Ihr Sat-Receiver bedient* - die richtige Sat-Nr. (entnommen der EGIS-Sat-Liste) an. Dabei schauen Sie immer auf das EGIS-Display. Es könnte jetzt z.B. S70 P11 erscheinen.
- Ein Satellit ist im EGIS-Steuergerät immer 20 Impulse breit. Versuchen Sie möglichst in die Mitte zu programmieren, also P10. Aber P08 bis P12 sind auch OK.

Fahren Sie mit der Programmierung Ihrer Satelliten, in beliebiger Reihenfolge, fort.

## Short operation instructions for SATELLITE-RECEIVER-INTERFACE (4-wire connection type)

- Install and build up the EGIS-Bi-Axial-Rotor, so that you can use the front buttons of the EGIS control unit free and safely to select a satellite,
- Disable auto-focus-funktion at your sat-receiver if necessary.
- Connect the supplied 4-wire cable to the motor output/pulse-input of the sat-receiver (see sketch at next page) and plug into the motor pulse jack of the EGIS control unit.
- Set to PRG 18 and press 2x ‚E‘nter.
- Set slide switch to ‚R‘un and select by using front pushbuttons the satellite your sat-receiver is tuned to. In the central of the EGIS display you will read S01 P10. The sat-receiver-pointer displays the first satellite of the EGIS SAT-listing.
- Under PRG 97 match the tuned satellite with East (2) and West (4) button to the satellite selected on the sat-receiver (see ref. no. in added EGIS SAT-listing).
- You may *store* this position as the first satellite *in your sat-receiver*.
- In the event that the receiver, however, requires the storage of east and west limits first, watch the middle part of the EGIS-display and drive - *operated via your sat-receiver* - to the Sat-No. of a extremely eastern situated satellite and *store* this position as eastern limit *in your Sat-Receiver*. After that - *operated by your sat-receiver* - drive to the Sat-No. of an extremely west situated satellite and store this position as western limit.
- If the receiver displays any motor-error or the display shows reverse operation (into erratic direction), you simply have to interchange the two wires leading to the motor fixings of the sat-receivers.
- After that, *using your sat-receiver*, select another satellite. The pointer in the EGIS-display may display an incorrect satellite. Now select *by using your own sat-receiver* the correct SAT-No. (see EGIS SAT-listing). Thereby always watch EGIS display. Now it might appear: S50 P08.
- Respective, after about 1 second pressing the pushbuttons of the sat-receiver, the rotor starts turning and matches the corresponding position.
- Now select, *via your sat-receiver*, another satellite. The pointer in the EGIS display may still show a false satellite. Now drive - *using your sat-receiver* - to the correct Sat-No. (see EGIS Sat-listing). Thereby constantly watch the EGIS-Display. Now it might appear S70 P11.
- Every satellite is always 20 impulses „wide“ at the control unit. Try to find out the middle, best P10, but P08 to P12 are also acceptable.

Continue programming your favorite satellites in any order:



- EQUIPMENT-GESELLSCHAFT für INTERN.  
ELEKTRONIK SYSTEME GmbH

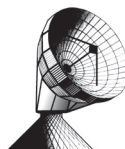

Flut-Str. 34-36  
D-63071 OFFENBACH/MAIN  
TEL. (++49) 69/858327  
FAX. (++49) 69/857863  
E-Mail: [Sat@EGIS.eu](mailto:Sat@EGIS.eu)  
<http://www.EGIS.eu>

25 minutes from Airport Frankfurt • 25 minutes from Frankfurt City

# SATELLITEN-RECEIVER-INTERFACE (4-wire Interface)

## Contact Assignment for the connection socket:

((Viewed from the solder lug side of the plug or rear side of equipment, respectively))

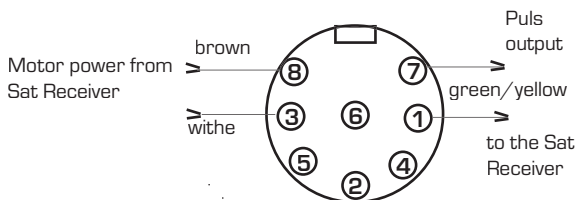

This interface described and used hereby is not a standardized Interface, however it is an often used one. You may already call it an "Industrial standard". Not only tuners and receivers with integrated power units offer these contacts, also tuners with stand alone power units use them (stand-alone positioner).

**Information about this function:** a DC voltage comes from the sat-receiver via the interface mentioned. The voltage is **about 36 V** to drive a **linear motor (actuator)**. Depending on the **polarity**, the motor runs to **eastern** or **western** positions. This way the receiver controls the desired position remote (**direction of the antenna beam**). During this motor-run a switch is **closed and opened** time after time **generating pulses**. The receiver counts these pulses and can assign different satellite positions corresponding to the amount of pulses in sequence: voltage comes out of the receiver – the motor runs – the motor switch operates – switch pulses will be counted by the receiver.

**Remarks belonging Twin-Axis-Rotor: start any action only after installing the rotor and control unit. Be sure and trained to operate the system by control keys or direct access precisely to select a satellite. Proceed with the connection of the receiver with the receiver-interface only after this configuration works properly.**

Plug in the supplied 4-wire cable into the left-hand (viewed from rear) jack.

Go to **PRG18**. Do not perform any actions right now. Confirm all positions with „E“nter (3x „E“). Using this **PRG 18** allows to see the **pulse-count** of the **selected satellite** via the receivers display – but **not** of the actual targeted satellite! Display: „**SxxPxx**“ where as „**Sxx**“ shows the selected satellite via **motor/puls interface** momentarily and „**Pxx**“ shows the corresponding state of the drive-back pulse counter.

Switch into „**RUN**“ mode now. To help you understanding the functions of the interface, you may connect a **9 V** battery to the free end of the cable, to the both wires leading to the motor (**contact 8 and 3**). Thereby watch the display. Interchange poles of battery several times (**minus** at brown **contact 8** and plus to white - **contact 3** - which means counting **upwards**). You will see, that you can change the SAT-No. by this and the rotor is targeting -after a waiting period- onto the selected satellite. Choose only satellites „**in sight**“, prefer south positioned satellites (i.e. Astra & Co. in Europe). Try out and play with this function.

If you own an **ohm-meter** or a **line tester**, you may perform a test using both other free cable ends (to **contacts 7 and 1**), whether the respective switching (pulses) are present.

You will notice, that according to **20 pulses** the switchover to the next

### Connections:

- motor controll voltage: 9 bis 50 V, approx. 940 Ohm
- pulse output: max. 50V, 100 mA (Reed-Relais)
- in- and output galvanic separated
- Socket: 8pol DIN Typ Hirschmann MABBSH

SAT-No. follows respectively. You may modify this certain pulse-figure per satellite under **PRG18**. However, the pretended values are proven.

In the same way you may select the transmission speed of the pulses (from **1 to 99** pulses/second, preset are **20 pulses/second**). Please use the given preset value. It's really proven.

Later on, if you have managed successfully the control via your sat-receiver, you may accelerate this transmission speed step by step to minimize the time for the sat-targeting.

Now connect your sat-receiver:

**Attention:** If the used sat-receiver has any autofocus function, all these must be disabled absolutely or programmed-out. This function has different names - auto-antenna, peak-function, auto peak and so on.

The four free ends of the of the cable are to be connected to the contacts of your sat-receiver or standalone positioner now, where normally the linear motor (actuator) is connected. If you recognize after the first operations, that reversal action occurs, please interchange the both wires „**MOTOR**“ (**contacts 8 + 3**).

The EGIS-rotor requires neither east- nor west-limits. It is controlling itself, any determination is not necessary. However, the commonly used sat-receivers require a fixing of eastern and western limits. Start now programming this. Use this limits for setting an invisible satellite respectively (any sat **behind the horizon**).

Thereby it is important, that you always have to watch the middle part of the rotor-controller-display and check the desired SAT-No. After pressing the key, the rotor starts to turn. There is nothing to be stored in the EGIS control unit. (If you own a receiver displaying pulse-numbers, you may program satellites without using the rotor-controller-display).

After calling and confirmation of **PRG18** from this moment till the next switch-off the unit the „**Lxxx**“-display is replaced by „**SxxPxx**“. Whereas „**Sxx**“ displays the momentarily selected satellites via **motor/pulse-interface**. „**Pxx**“ shows the actual state of the pulse counter.

**PRG18** is followed by another input field after the first „E“nter to set the type of tuner used, completed by „E“nter:

- |         |  |
|---------|--|
| display | <b>00</b> = standard (your receiver)           |
|         | <b>01</b> = MACAB                              |
|         | <b>02</b> = from here on not used at this time |

After this input field the field „**PULS REST**“ appears automatically. By this you can preset the time interval, in which the rotor waits until starting the



- EQUIPMENT-GESELLSCHAFT für INTERN.  
ELEKTRONIK SYSTEME GmbH

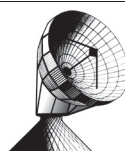

Flut-Str. 34-36  
D-63071 OFFENBACH/MAIN  
TEL. (++49) 69/858327  
FAX. (++49) 69/857863  
E-Mail: Sat@EGIS.eu  
http://www.EGIS.eu

25 minutes from Airport Frankfurt • 25 minutes from Frankfurt City

# SATELLITE-RECEIVER-INTERFACE (4-wire Interface)

motors, after receiving the receiver-positioning-voltage. Please confirm with „E“nter; you may change these settings later on.

An effective kind of tuner programming results this way:

As already mentioned, take **PRG18** and close with 3 x „E“nter, so that „Sxx Pxx“ is shown in the display. The rotor control-unit is almost always ready (exception: several special PRG memories) to serve the motor/pulse-interface and send back pulses. The remote controlled position will be internally counted and, according to the time preset under „**MOTOR REST**“ (presetting 1 sec.), the positioning starts after voltage cut-off. If the mode-switch is not set to „**RUN**“, the positioning will start after the switch is set to „**RUN**“.

Via this interface all positions are available always.

If you select a free and not pre-programmed satellite-position not yet engaged or a physical **not-in-sight** satellite (**behind the horizon**) or any position outside of the mechanical moving limits of the rotor, no action is performed.

The „Bi-Axial-Rotor“ should be switched on always prior to the tuner and switched off after the tuner; this way the pulse output restores his last level again and no pulse-information will be lost. With the widely spread sat-tuners this measure is unnecessary indeed, because these proceed the pulse information only during and short after motor actions.

The described and used interface is not a standardized Interface, it is wide-spread anyway. You may already talk of an „industrial standard“. If this interface is utilized at your tuner/receiver it should be utilized as described above.

If the receiver used has an input/output to a power stand-alone unit (Positioner), you may use (under certain, seldom occurring circumstances) its input/output direct, to connect it to our 2-axis control unit. Please call us, we are able help you in most cases. For the engineer here - in advance - some information:

Pins used in the interface without separate power unit:

**Pin 8** = +5 to max. 50 V  
**Pin 2** = motor on  
**Pin 5** = direction.

Operating with „open collector output“:

At **pin 8** an external voltage is applied (i.e. + from the **+24 V DC** from the rear side of the 2-axis control-unit). The ground (**0 V**) of this voltage must be connected to the ground of the motor jack of the SAT-tuner.

## **PRG18 type 00:**

If **pin 2** is drawn to ground (**0 V**) by the transistor in the tuner, then the rotor counts into one direction. If **pin 5** is drawn to ground (**0 V**), thus is counted into the opposite direction.

## **PRG18 type 01:**

If tuner-type **01** is chosen, then there is counted only (pulsated) as far as **pin 2** is drawn to ground (**0 V**). The direction is depending on the voltage at **pin 5**.

With **REC. PULS SYNCHRONISATION (PRG 97)** you get information about the state of the satellite-pointer from the satellite-receiver. You will realize - as described above - onto which satellite the sat-receiver is engaged in this moment, connected via the **motor/pulse-interface** (4-wire interface).

„**S**“ shows the number of the selected satellite, „**P**“ the position of the pulse-pointer belonging to this satellite.

With keys „**2**“ (EAST) and „**4**“ (WEST) you are able to rearrange the pointer to the desired starting position (the basic operation is progressive in time - so the speed of steps increases by time). By this it is possible now, to synchronize the rotor with the receiver and not vice versa only.

**PRG18** serves for the entry of interface parameters and for interface monitoring furthermore.

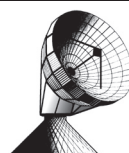

## Installations- und Betriebs-Handbuch

# PROFITRACKER CL

## *GPS Extension*

### GPS connection & use

The GPS-receiver ‚GPS II fl2‘ can only be used and operated in connection with EGIS bi-axial-controllers equipped with firmware V8042 (or more recent) or V8359 (or more recent) (please see PRG 99).

- The GPS-receiver is also inclusive of the necessary GPS-antenna. This unit must be mounted in such a way, that GPS-satellite transmitted signals are able to reach the receiver, respectively the antenna (ideally near to the window, so that a reception is possible).

- Join the D-SUB9-plug of the GPS-receiver to the rear configured interface of the controlling device.

- Connect the power supply part (version including a DC 12 V or AC 230 V adapter) to the GPS- receiver and supply with power via corresponding socket.

Once it has been switched-on, the device will check for five seconds whether a GPS receiver has been connected to the serial interface.

If, during this period, no GPS receiver is recognised, the device will take up its normal operation with the accuracy of a crystal-controlled clock.

In case a GPS signal is detected, the transmitted location and time will be displayed for a short time. Then the controller will wait for the ‚Valid‘-signal of the GPS receiver, but only for a maximum of 5 minutes.

If no evaluable signal can be received, the controller will likewise pass on to quartz-controlled operation.

If a valid signal is detected, the controlling device will acknowledge this by three short signal tones.

Afterwards, the device will update time and date of its own clock, then pass on to its normal operation.

Every morning, when the controlling device performs a ‚Run of Origin‘, the time is verified and reset, if necessary.

If no time-signal is received during this process, the equipment will continue to work with the accuracy of a quartz-clock.

Now the system pass on to its normal operation.



-EQUIPMENT-GESELLSCHAFT für INTERN.  
ELEKTRONIK SYSTEME GmbH

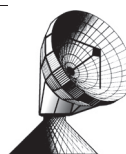

Flut-Str. 34-36  
D-63071 OFFENBACH/MAIN  
TEL. (+49) 69/858327  
FAX. (+49) 69/857863  
E-Mail: [Sat@EGIS.eu](mailto:Sat@EGIS.eu)  
<http://www.EGIS.eu>

*25 Minuten vom Airport Frankfurt • 25 Minuten von Frankfurt City*

# PROFITRACKER CL

## Rotor Pass Parameter Table

Device	S/N.	Position
Rotor:		
Controller:		
Total Movement range of Rotator: AZ =		EL =

*Please note here your local calculated values also:*

Local Geo-Coordinates:	(PRG 01)	Lon =	Lat =
Reference/ORG Point Data:	(PRG 02)	AZ =	EL =
Jogpuls with:	(PRG 13)	AZ =	EL =
Motor Rest:	(PRG 14)	AZ =	EL =
ROTOR LIMIT:	(PRG 21)	AZ =	EL =
ROTOR TYPE:	(PRG 22)	AZ =	EL =
Hight Speed:	(PRG 25)	AZ =	EL =
Low Speed:	(PRG 26)	AZ =	EL =
Speed-Up:	(PRG 27)	AZ =	EL =
Slow down:	(PRG 28)	AZ =	EL =
Servo:	(PRG 29)	AZ =	EL =
PARK POSITION:	(PRG 36)	AZ =	EL =
Time out:	(PRG 38)	AZ =	EL =
GEAR°/PULSE RATE:	(PRG 41)	AZ =	EL =
Shutdown axis:	(PRG 45)	AZ = on	EL = on
Min. Stepwith:	(PRG 46)	AZ =	EL =
SLEEP POSITION:	(PRG 51)	AZ =	EL =
Time & Date:	(PRG 52)	h : m : s	
INTERVAL:	(PRG 53)	h : m : s	__ : __ : __
Windsensor settings:	(PRG 40/1) Wind Sensor (PRG 40/2) Wind Survival Pos. (PRG 40/3) Wind Threshold (PRG 40/4) Wind Return Delay	meter/puls ° km/h minutes	



**-EQUIPMENT-GESELLSCHAFT für INTERN.  
ELEKTRONIK SYSTEME GmbH**

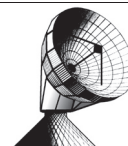

Flut-Str. 34-36  
D-63071 OFFENBACH/MAIN  
TEL. (+49) 69/858327  
FAX. (+49) 69/857863  
E-Mail: [Sat@EGIS.eu](mailto:Sat@EGIS.eu)  
<http://www.EGIS.eu>

*25 minutes from Airport Frankfurt • 25 minutes from Frankfurt City*

# Installation and Operation Manual

## **PROFITRACKER CL**

### Manufacturer's Declaration

in terms of the EC-Directive of Machinery 2006/42/EC

The machinery, which is described in the following, is in accordance with the requirements of the EC-Directive of Machinery 2006/42/EC. The machinery must not be placed on marketed in this version. It has been handed over not ready for operation. Before marketing, the machinery has to be made conform to the before mentioned directive.

We certify that the device covering the

EMC Directive (2004/108/CE)

Low Voltage Directive EN 60950-1 :2001

Machinery: Bi-Axial-Positioning-System 'PROFITRACKER CL'  
EPR-203

Manufacturer: EGIS-Equipment-GmbH  
Flutstr. 36  
D-63071 Offenbach am Main  
Germany

Offenbach, 24.9.2008

EGIS-Equipment-GmbH

  
Eng. Dieter Meixner  
(Executive Director)



-EQUIPMENT-GESELLSCHAFT für INTERN.  
ELEKTRONIK SYSTEME GmbH

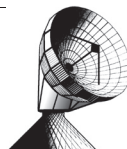

Flut-Str. 34-36  
D-63071 OFFENBACH/MAIN  
TEL. (+49) 69/858327  
FAX. (+49) 69/857863  
E-Mail: [Sat@EGIS.eu](mailto:Sat@EGIS.eu)  
<http://www.EGIS.eu>

*25 minutes from Airport Frankfurt • 25 minutes from Frankfurt City*



# Installation and Operation Manual

## PROFITRACKER CL



EGIS-Equipment-GmbH  
FLUTSTR. 34-38  
D-63071 OFFENBACH / Germany  
Tel. (+49) 69/858327  
Fax.(+49) 69/857863

### EC Declaration of Conformity

» PROFITRACKER CL «  
EPS-103

The product specified by „description“ and „type“ fulfils the requirements of the below mentioned EU-Directive.

EC-Directive:	Low Voltage Directive	EN 60950-1 :2001
	Electromagnetic Compatibility Directive	2004/108/CE
Description:	Bi axial motor controller	Type: Profitracker CL EPS-103

Offenbach/Main, 22-09-2010

Eng. Dieter Meixner (Executive Director)



-EQUIPMENT-GESELLSCHAFT für INTERN.  
ELEKTRONIK SYSTEME GmbH

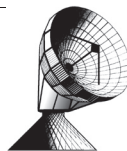

Flut-Str. 34-36  
D-63071 OFFENBACH/MAIN  
TEL. (+49) 69/858327  
FAX. (+49) 69/857863  
E-Mail: Sat@EGIS.eu  
<http://www.EGIS.eu>

25 minutes from Airport Frankfurt • 25 minutes from Frankfurt City

Annex: XI/2